Contents

Contents	I
1 Abstract	1
1.1 Safety Precautions	1
1.2 Series Introduction	10
1.3 Name of Each Part of the Servo Drive	11
1.4 Basic Information of Servo Drive	12
1.4.1 Installation Dimensions	12
1.4.2 Installation Way	14
1.4.3 Specifications and Electric Parameters	15
1.4.4 Basic specifications	16
1.5 System Diagram	20
1.6 System Configuration Examples	21
1.7 Drive Name	22
1.8 Maintenance and Inspection of Servo Drive	23
1.8.1 Inspection of Servo Motor	23
1.8.2 Inspection of Servo Drive	23
1.8.3 Approximate Standards for Changing Internal Parts of Servo Drive	24
1.8.4 Precautions during Operation and Running	24
1.9 Motor Name	25
1.10 Dimension of Motors	26
2 Panel Operation	32
2.1 Basic Operation	32
2.1.1 Keys' Names and Functions of the Panel Operator	32
2.1.2 Functions Switch	33
2.1.3 Status Display	33
2.2 Operations of Auxiliary Functions (Fn group)	34
2.3 Operations of Parameter (Pn Group)	34
2.4 Operations of Monitoring Display Un Group	35
3 Wiring and Connections	36
3.1 Main Circuit Wiring	36
3.1.1 Terminals Description	36
3.1.2 Recommended Model and Specification of Main Circuit Connection Cable	37
3.1.3 Wiring Diagram	38
3.1.4 Main Circuit Wiring Requirements	41
3.2 Motor Power Line Connection	42
3.3 CN2 Encoder Connection	44
3.4 Holding Brake Line Connection	45
3.5 CN7 USD Communication Terminal (Connect to Host Machine)	47
3.6 Connection of CN6A and CN6B Communication Terminal	47
3.7 CN5 Full Closed Loop Port	48
3.8 CN1 Multifunctional Control Terminal Definition	50
3.9 Digital Input Signal	51
3.9.1 Input Signal Descriptions	51
3.9.2 Input Signal Configuration	52

3.9.3 Confirming the Input Status	54
3.10 Digital Output Signal	54
3.10.1 Output Signal Descriptions	54
3.10.2 Output Signal Configuration	56
3.10.3 Confirming the Output Status	56
3.11 Connection with the Upper Device	57
3.11.1 Analog Input Circuit	57
3.11.2 Position Instruction Input Circuit	57
3.11.3 Sequence Control Input Circuit	61
3.11.4 Sequence Output Loop	61
3.12 Position Control Wiring Diagram	63
3.13 Speed Control Wiring Diagram	64
3.14 Torque Control Wiring Diagram	65
3.15 Regenerative Resistor Connection	66
3.15.1 Connection of Regenerative Resistors	66
3.15.2 Selection of Regenerative Resistor	66
3.16 Fuse	67
3.17 Circuit Breaker	68
3.18 EMC Filter	69
3.19 Noise and High Harmonic Countermeasures	69
4 Trial Operation	71
4.1 Inspections and Notes before Trail Operation	71
4.1.1 Conditions of the Servo Motor	71
4.1.2 Conditions of the Servo Drive	71
4.1.3 Installation	71
4.2 JOG Trail Operation	71
5 Operation	72
5.1 Basic Functions	72
5.1.1 Quick Guide	72
5.1.2 Servo Enable and Over-Travel Setting	72
5.1.3 Motor Rotation Direction	74
5.1.4 Stop Mode	74
5.1.5 Electromagnetic Brake	75
5.1.6 Regenerative Resistor	77
5.1.7 Overload	77
5.1.8 Multi-turn Absolute Encoder	79
5.1.9 Torque Limit	80
5.2 Position Mode	82
5.2.1 Quick Guide	82
5.2.2 Basic Settings	83
5.2.3 Deviation Clearance	85
5.2.4 Command Pulse Prohibition	86
5.2.5 Positioning Approach	86
5.2.6 Positioning Completion	87
5.2.7 Command Pulse Input Magnification Switching	88
5.2.8 Smooth Settings	89
5.2.9 Frequency-division Output	90
5.3 Speed Mode	93
5.3.1 Quick Guide	93

5.3.2 Basic Settings	93
5.3.3 Soft Start	96
5.3.4 Zero Fixed Functions	97
5.3.5 Rotation Detection Signal	98
5.3.6 Consistent Speed	99
5.4 Torque Mode	100
5.4.1 Quick Guide	101
5.4.2 Basic Setting	101
5.4.3 Adjustment of Command Offset	103
5.4.4 Speed Limit in Torque Control	104
5.5 Hybrid Control Mode Selection	104
5.6 Other Output Signals	107
5.6.1 Servo Ready Output Signal	107
5.6.2 Warning Output Signal	107
5.7 Timing Sequence	109
5.7.1 Power Enable ON Timing sequence	109
5.7.2 Power-Off Enable OFF Timing Sequence	110
5.8 Full Closed Loop Control	110
5.8.1 What Is a Fully Closed Loop System	110
5.8.2 Parameter Setting of Full Closed-Loop Control	111
5.8.3 Control Block Diagram of Full Closed Loop Control	112
5.8.4 Setting of Motor Rotation Direction And Machine Moving Direction	112
5.8.5 Resolution of External Grating Ruler	113
5.8.6 Setting of Frequency Division Pulse Output Signal of Grating Ruler / Encoder	114
5.8.7 Setting of Electronic Gear	115
5.8.8 Setting of alarm detection	117
6 Adjustment	119
6.1 Adjustments	119
6.1.1 Adjustments Steps	119
6.1.2 Safety Precautions When Adjusting	120
6.2 Robust Control	121
6.2.1 Summary	121
6.2.2 Operating Procedure	122
6.2.3 Additional Notes	123
6.2.4 Related Parameters	123
6.3 Inertia Identification	124
6.3.1 Summary	124
6.3.2 Steps	124
6.3.3 Additional Notes	124
6.4 Intelligent Setting	125
6.4.1 Summary	125
6.4.2 Steps	126
6.4.3 Additional Notes	127
6.4.4 Related Parameters	128
6.5 Bandwidth Setting	129
6.5.1 Profile	129
6.5.2 Steps	129
6.5.3 Additional Notes	130
6.5.4 Related Parameters	131

6.6 Manual Adjustment Function.....	132
6.6.1 Servo Gain	132
6.6.2 Gain Switching	134
6.6.3 Speed Feedforward.....	137
6.6.4 Torque Feedforward	137
6.6.5 PI-P Switching	138
7 Auxiliary Functions	142
7.1 List of Auxiliary Functions	142
7.2 Alarm Records Display (Fn000)	142
7.2.1 Overview	142
7.2.2 Operating Procedure.....	143
7.3 Clear Alarm Record (Fn001)	143
7.3.1 Summary	143
7.3.2 Operating Procedure.....	143
7.4 Software Reset (Fn002).....	143
7.4.1 Summary	143
7.4.2 Operating Procedure.....	144
7.5 Restore Factory Parameters (Fn003)	144
7.5.1 Overview	144
7.5.2 Operating Procedure.....	144
7.6 JOG Operation (Fn005)	144
7.6.1 Overview	144
7.6.2 Operating Procedure.....	145
7.7 Program JOG Operation (Fn006)	145
7.7.1 Overview	145
7.7.2 Operating Procedure.....	146
7.8 Automatic Adjustment of Command Offset (Fn100)	146
7.8.1 Overview	146
7.8.2 Operating Procedure.....	146
7.9 Speed command Offset Manual Adjustment (Fn101).....	147
7.9.1 Overview	147
7.9.2 Operating Procedure.....	147
7.10 Torque Command Offset Manual Adjustment (Fn102)	147
7.10.1 Overview	147
7.10.2 Operating Procedure.....	148
7.11 Current Offset Automatic Adjustment (Fn103)	148
7.11.1 Overview.....	148
7.11.2 Operating Procedure	148
7.12 Current Offset Manual Adjustment (Fn104).....	148
7.12.1 Overview	148
7.12.2 Operating Procedure.....	149
7.13 Initializing the Detection Value of Vibration Detection (Fn105).....	149
7.13.1 Overview	149
7.13.2 Operating Procedure.....	150
7.14 Bandwidth Settings (Fn303).....	150
7.14.1 Overview	150
7.14.2 Operating Procedure.....	151
7.15 EasyFFT (Fn401).....	151
7.15.1 Overview	151

7.15.2 Operating Procedure	152
7.16 Online Vibration Monitoring (Fn402)	152
7.16.1 Overview	152
7.16.2 Operating Procedure	152
8 Home Position Return and Internal Positions	153
8.1 The Principle of Home Position Return Function	153
8.1.1 Home Position Return Trigger	155
8.1.2 Home Position Return SI Terminal Trigger	155
8.1.3 Home Position Return Automatically Trigger When Power On	155
8.1.4 Home Position Return Triggered By Point Function	156
8.1.5 Communication Triggers Home Position Return	156
8.2 Home Position Return Function Code	156
8.3 Home Position Return Method	159
8.3.1 Home Position Return Method 1	159
8.3.2 Home Position Return Method 2	160
8.3.3 Home Position Return Method 3	161
8.3.4 Home Position Return Method 4	162
8.3.5 Home Position Return Method 5	163
8.3.6 Home Position Return Method 6	164
8.3.7 Home Position Return Method 7	165
8.3.8 Home Position Return Method 8	166
8.3.9 Home Position Return Method 9	168
8.3.10 Home Position Return Method 10	169
8.3.11 Home Position Return Method 11	172
8.3.12 Home Position Return Method 12	173
8.3.13 Home Position Return Method 13	175
8.3.14 Home Position Return Method 14	176
8.3.15 Home Position Return Method 15	178
8.3.16 Home Position Return Method 16: Reserved	178
8.3.17 Home Position Return Method 17	178
8.3.18 Home Position Return Method 18	179
8.3.19 Home Position Return Method 19	179
8.3.20 Home Position Return Method 20	180
8.3.21 Home Position Return Method 21	181
8.3.22 Home Position Return Method 22	182
8.3.23 Home Position Return Method 23	183
8.3.24 Home Position Return Method 24	184
8.3.25 Home Position Return Method 25	186
8.3.26 Home Position Return Method 26	187
8.3.27 Home Position Return Method 27	189
8.3.28 Home Position Return Method 28	190
8.3.29 Home Position Return Method 29 (6098 00h=29)	192
8.3.30 Home Position Return Method 30 (6098 00h=30)	193
8.3.31 Home Position Return Method 31 (6098 00h=31): Reserved	195
8.3.32 Home Position Return Method 32 (6098 00h=32): Reserved	195
8.3.33 Home Position Return Method 33 (6098 00h=33)	195
8.3.34 Home Position Return Method 34 (6098 00h=34)	195
9 Internal Position	197
9.1 The Position Control Function Code Parameter Setting	197

9.2	Position Control Related Function Code	198
9.2.1	Function Code Description	198
9.2.1.1	Position Command Trigger, Select, Stop	198
9.2.2	Position Command Control Parameter Configuration	200
9.2.3	Position Command Segment Pulse Given	208
9.2.4	Position Command Segment Sharing Parameters	209
9.3	The Point Function Operating Parameters	213
9.3.1	Position Command	213
9.3.2	Acceleration and Deceleration Time	214
9.3.3	Point Position Control Speed and Delay Time	215
9.4	The Interrupt Function	216
9.4.1	Incremental Position Interrupt Position Command	216
9.4.2	Equivalent Position Command Insertion Position Command	217
9.4.3	Absolute Position Interrupt Position Command	217
9.4.4	Multi-segment Storage Function	218
9.4.5	Overlapping Storage Function	219
9.4.6	Interrupt Storage Function	220
9.5	Overlapping Function	220
9.6	Stop Function	221
9.7	Jump Function	222
9.8	Jog Function	224
9.8.1	Jog Operation of External Terminals	225
9.8.2	Communication Jog	225
10	Function Code Instructions	226
10.1	Pn0 Group Basic Control Related Parameters	226
10.2	Pn1 Group Gain Parameters	231
10.3	Pn2 Position Related Parameters	237
10.4	Pn3 Group Speed Related Parameters	243
10.5	Pn4 Group Torque Related Parameters	244
10.6	Pn5 JOG Related Parameters	246
10.7	Pn6 Group Switch Configuration Related Parameters	246
10.8	Pn7 Group Expansion Related Parameters	249
10.9	Pn8 Group Internal Position/Home Position Return Parameters	251
11	Monitoring Parameters	258
12	Fault Code and Countermeasures	262
12.1	Fault Code	262
12.2	Warning Code	266
13	Communication	268
13.1	Communication Introduction	268
13.2	RS485 Communication Protocol Description	268
13.3	Communication Frame Structure	268
13.4	Command Code and Communication Data Description	269
13.5	Communication Frame Error Check Mode:	271
13.5.1	Byte Bit Check	271
13.5.2	CRC Check Method --- CRC (Cyclical Redundancy Check)	271
13.6	Error Message Response	271
14	Host Debugging Instruction	273
14.1	System Requirements	273
14.1.1	System Configuration	273

14.1.2 Connection Configuration.....	273
14.2 Main Interface	274
14.3 Features	275
14.4 Real-Time Monitoring.....	279
14.5 Auxiliary Functions	279
14.5.1 JOG	279
14.5.2 Inertia Identification	280
14.5.3 Program JOG	282
14.5.4 Mechanical Characteristics	282
14.5.5 FFT Analysis.....	284
14.5.6 Bandwidth setting.....	284
14.5.7 Offset Adjustment.....	286
14.5.8 Return to Origin.....	286
14.5.9 Soft Reset.....	287
14.5.10 Restoring the Factory Value.....	287
14.5.11 Fault Information.....	288
14.6 Digital Oscilloscope.....	288
14.6.1 Real-Time Acquisition	291
14.6.2 Trigger Acquisition.....	291
14.6.3 Graphic Operations	292
14.7 Others	296
14.7.1 Window Display.....	296
14.7.2 Help	297
15 Appendix	298
15.1 Compliance with Certification and Standard Requirements	298
15.1.1 CE Certification	298
15.1.2 Conditions of Compliance with EMC Directive.....	298
15.1.3 EMC Standard Introduction.....	299
15.1.4 Conditions of compliance with the LVD Low Voltage Directive	299



1 Abstract

1.1 Safety Precautions

To ensure safe and reasonable use of this product, please use the product only after fully understanding the safety precautions described in this manual.



- **Warning signs and their meanings**

The following markings are used in this manual to indicate that the place is important regarding safety. Failure to observe these precautions may result in personal injury or death, damage to this product and associated systems. And the listed points do not represent all safety matters to be observed, but only serve as a supplement to all safety precautions.

 Danger
● It indicates an emergency and dangerous situation that is likely to result in death, serious injury and fire if not avoided.
 Warning
● Indicates a dangerous condition that could result in death, serious injury and fire if not avoided.
 Attention
● Indicates a dangerous condition that could lead to moderate or minor injuries and fire if not avoided.
Notice
● Indicates a dangerous condition that could lead to equipment damage if not avoided.

- **Safety Precautions**

- Overall Precautions

 Danger
● For your safe use of the product, please be sure to read this manual. ● Keep this manual in a safe place so that it can be accessed by the person using the product at any time. ● Do not remove the cover, cables, connectors, and optional equipment while the servo unit is powered on. Otherwise, it may cause electric shock, stop the operation of the product or burn out.
 Warning
● Please use the product under the power specifications (phase, voltage, frequency) that match the product. Otherwise, the product may be burnt, electric shock or fire.

● Be sure to connect the ground terminal of the servo unit and servo motor to the ground pole.

Otherwise, it may cause electric shock or fire.

● Do not disassemble, repair or modify the product.

Otherwise, it may cause a fire or malfunction.

Disassembled, repaired or modified products are not covered by the warranty.



Attention

● The heat sink of the servo unit, regenerative resistor servo motor, etc. may be at high temperature when the power is turned on or just after the power is turned off. Please take safety measures such as installing an outer cover to avoid accidental touching of hands and parts (cables, etc.).

Otherwise, it may cause burns.

● Do not damage or pull the cable by force, or subject the cable to excessive force, place it under heavy objects or cause it to be clamped.

Otherwise, it will cause malfunction, damage, and electric shock.

● Do not use the product in places where water can be splashed, in corrosive environments, in flammable gas environments, or near combustible materials.

Otherwise, it may cause electric shock or fire.

Notice

● Do not use servo units and servo motors that are damaged or have missing parts.

● Set up an emergency stop circuit externally to ensure that power is cut off and operation is stopped immediately in the event of an abnormality.

● If the Servo Unit is used under poor power conditions, install protection equipment (AC reactor, etc.) to ensure that the input power is supplied within the specified voltage variation range.

Otherwise, the servo unit may be damaged.

● Use a noise filter, etc. to reduce the influence of electromagnetic interference.

Otherwise, electromagnetic interference may be caused to electronic equipment used near the servo unit.

● Use the Servo Unit and Servo Motor in the specified combination.

● Do not touch the servo unit and servo motor with wet hands.

Otherwise, the product may malfunction.

■ Precautions During Storage



Attention

● Do not stack this product too much (follow the instructions), otherwise it may cause injury or malfunction.

Notice

- Please keep and install it in the following environment.
 - Place where there is no direct sunlight
 - Place where the ambient temperature does not exceed the product specifications
 - Places where the relative humidity does not exceed the product specifications
 - Place where there is no condensation due to sharp changes in temperature
 - Places where there are no corrosive gases or combustible gases
 - Place where there are no combustible materials in the vicinity
 - Places where there is little dust, dirt, salt and metal powder
 - Places where water, oil and drugs are not easily splashed
 - Places where vibration or shock will not affect the product (places exceeding product specifications)
 - Places where the product will not be subjected to radiation that could cause product failure or damage when stored or installed in environments other than the above.

■ Precautions During Handling



Attention

- Please use the correct method for handling according to the weight of the product.
- Do not use the lifting bolts of servo units and servo motors to carry the machinery. Failure to do so may result in injury or equipment failure.
- When handling the servo unit and servo motor, please pay attention to the sharp parts such as the corners of the equipment. Failure to do so may result in injury.
- Do not stack this product too much (Follow the instructions.), Failure to do so may result in injury or malfunction.

Notice

- When handling the Servo Unit, do not hold the front cover and connectors. Otherwise, the servo unit may fall off.
- The servo unit and servo motor are precision equipment. Do not drop it or apply strong impact on it. Otherwise, malfunction or damage may occur.
- Do not apply impact to the connector part. Otherwise, poor connection or malfunction may occur.
- If wood for packaging (including wood frames, plywood, pallets, etc.) needs to be disinfected or disinfected, be sure to use a method other than fumigation.

Example: Heat treatment (core temperature of 56°C or more for more than 30 minutes) Also, treatment must be done at the material stage before packaging, not as a whole after packaging.

When packaging electrical products (stand-alone or loaded on machinery, etc.) with fumigated wood, the gases and vapors generated by the wood can be fatal to electronic components. In particular, halogen-based disinfectants (fluorine, chlorine, bromine, iodine, etc.) may cause internal corrosion of capacitors.

- Do not over-tighten the lifting bolts of the servo unit and servo motor.
 - Strong tightening with implements, etc. may cause breakage of the screw holes.

■ Precautions During Installation



Attention

- Install the Servo Unit and Servo Motor in a position with sufficient weight resistance in accordance with the technical data.

- Install the servo unit, servo motor, regenerative resistor and dynamic braking resistor on non-combustible materials.

Direct installation on or near combustible materials can cause a fire.

- During installation, be sure to maintain the specified separation between the Servo Unit and the inner surface of the control cabinet and other machines.

Otherwise, it may cause a fire or malfunction.

- Install the Servo Unit in the specified direction.

Otherwise, it may cause a fire or malfunction.

- Do not step on this product or place heavy objects on it.

Otherwise, malfunction, damage or injury may occur.

- Do not allow other materials to enter the servo unit and servo motor.

Otherwise, it may cause malfunction or fire.

Notice

- Please keep and install in the following environment.
- Places where there is no direct sunlight
- Place where the ambient temperature does not exceed the product specifications
- Place where the relative humidity does not exceed the product specifications
- Place where there is no condensation due to sharp temperature difference
- Place where there is no corrosive gas or combustible gas
- Place where there are no combustible materials nearby
- Place where there is little dust, dirt, salt and metal powder
- Place where water, oil and medicine are not easily splashed
- Place where vibration or shock will not affect the product (place that exceeds product specifications)
- Place where radiation will not be received
- When stored or installed in an environment other than the above, the product may malfunction or be damaged
- Please use it in an environment that meets the product specifications.

When used in an environment that exceeds the product specification, the product may fail or be damaged.

- The servo unit and servo motor are precision equipment. Do not drop it or apply strong impact on it.

Otherwise, it may cause malfunction or damage.

- Make sure that the servo unit is installed in the control cabinet.
- Do not block the air inlet and exhaust ports of the Servo Unit and Servo Motor with cooling fan, or allow other materials to enter the product.
- Otherwise, it may cause malfunction.

■ Precautions During Wiring



Danger

- Do not change the wiring during the power-on process. Otherwise, it may cause electric shock or injury.



Warning

- The wiring or inspection operation should be carried out by a professional technician. Otherwise, it may cause electric shock or product failure.
- Please check the wiring and power supply carefully.

The output circuit may be short-circuited due to incorrect wiring or the application of a different voltage. In the event of such a fault, the brake will not operate, which may result in mechanical damage or injury to personnel.

- When using a servo unit for which the dynamic brake option is available, connect the external dynamic brake resistor that corresponds to the specifications of the machine or device to the specified terminal.

Otherwise, in case of emergency stop, it may cause accidental operation, resulting in damage to equipment, burnout, and injury to personnel.



Attention

- Make sure that the (CHARGE) light is off at least 10 minutes after the power is turned off, and then proceed with wiring and inspection. Even if the power is turned off, high voltage may remain inside the servo unit. Therefore, do not touch the power terminals while the (CHARGE) light is on.

Otherwise, it may cause electric shock.

- Follow the precautions and procedures described in this manual for wiring and test operation.

The servo unit malfunction caused by incorrect wiring of the brake circuit, application of a different voltage, etc. may cause mechanical damage or injury to persons.

- Make sure that the wiring is done correctly and reliably.

The pin arrangement of connectors and connectors varies depending on the model. Be sure to check the pin arrangement with the technical data of the model used.

Failure to do so may result in product failure or malfunction.

- Make sure to tighten and securely connect the wires of the power terminal and motor connection terminal according to the specified method and torque.

Failure to tighten them sufficiently may cause the wires and terminal blocks to heat up and cause a fire due to poor contact.

- Use shielded double-stranded stranded wire or multi-core double-stranded stranded integral shielded wire for input and output signal cables and encoder cables.

- When wiring the main circuit terminals of the servo unit, be sure to observe the following precautions.

Turn on the power to the Servo Unit after all the wiring, including the main circuit terminal, is completed.

If the main circuit terminal is a connector type, remove the connector from the main body of the Servo Unit before wiring.

Only one wire can be inserted into each wire socket of the main circuit terminal.

When inserting the wires, do not short-circuit the adjacent wires by making contact with the burrs of the core wires.

- Install a safety device such as a circuit breaker for wiring to prevent short circuiting of external wiring.

Otherwise, it may cause fire or malfunction.

Notice

- Please use our specified cables for wiring as much as possible.

If you use a cable other than the one specified by us, use the wiring material specified by us or an equivalent product after checking the rated current of the type used and the operating environment.

- Make sure to tighten the fixing screws and locking mechanism of the cable connector.

Insufficient tightening may cause the cable connector to fall off during operation.

- Do not use the same sleeve for strong power cables (main circuit cables) and weak power cables (cables for input and output signals and encoder cables), or tie them together. If you do not put strong and weak cables in separate sleeves, keep a distance of 30cm or more between them when wiring.

If they are too close together, the weak power cables may be interfered with and cause malfunction.

- Install the battery on either side of the upper unit or encoder cable.

If the battery is installed on the upper unit and encoder cable at the same time, a loop circuit will be formed between the batteries and the product will be damaged or burned.

- When connecting the battery, please pay attention to the polarity.

A broken battery can cause the encoder to malfunction.

■ Precautions During Operation and Running



Warning

- Before installing the machine and starting operation, perform the switch and parameter settings appropriate to the machine.

If you operate the machine without setting, it may cause accidental operation, malfunction or injury to people.

- Do not make extreme changes to the parameter settings.

Otherwise, it may cause unstable operation, mechanical damage or injury.

- To avoid accidents, install a limit switch or stopper at the end of the movable part of the machine.

Otherwise, it may cause damage or injury to the machine.

- Perform the test run with the servo motor fixed and disconnected from the machine.

Otherwise, injury may occur.

- Do not enter the operating range of the machine during operation.

Otherwise, injury may occur.

- Do not touch the servo motor or the movable part of the machine during operation.

Otherwise, injury may occur.



Attention

- Please design a safety system to ensure safety even in the event of a fault such as a broken signal line.

For example, a safety action is performed when the P-OT signal and N-OT signal are disconnected at the factory setting. Do not change the polarity of these signals.

- When overtravel occurs, the motor is not energized and the brake is released. If the servo motor is used for vertical drive, set the motor to enter the zero fixed state after it stops. Also,

use safety devices (external brakes and counterweights, etc.) to prevent the movable part of the machine from falling off.

Notice

- For gain adjustment when the system starts, check the torque waveform and speed waveform with a measuring instrument to make sure there is no vibration.

If vibration occurs due to high gain, the servo motor may be damaged prematurely.

- Do not turn ON/OFF the power frequently. After starting actual operation (regular operation), the power supply should be turned ON/OFF at intervals of at least 1 hour (approximate standard).

Do not use this product in applications where the power supply is turned ON/OFF frequently.

Otherwise, it may cause the components inside the servo unit to be damaged prematurely.

■ Precautions During Maintenance and Inspection



Danger

- Do not change the wiring during the power-on process. Otherwise, it may cause electric shock or injury.



Warning

- Wiring or inspection operations should be performed by a professional technician. Failure to do so may result in electric shock or product failure.



Attention

- Make sure that the (CHARGE) light turns off after the power is turned off for at least 10 minutes, and then proceed with wiring and inspection. Even if the power is turned off, high voltage may remain inside the servo unit. Therefore, do not touch the power terminals while the (CHARGE) light is on.

Otherwise, it may cause electric shock.

- When replacing the Servo Unit, make a backup copy of the Servo Unit parameters before replacing it. Copy the backed-up parameters to the new Servo Unit, and make sure that the copy operation is completed correctly.

If the backed-up parameters are not copied or the copying operation is not completed correctly, it will cause damage to the machinery and the unit, and thus it will not operate properly.

Notice

- Please remove static electricity before operating the buttons and switches inside the front cover of the servo unit.

Otherwise, it may cause damage to the machine.

■ Precautions Related to Handling in Case of Abnormalities



Danger

- When the safety device (circuit breaker and fuse for wiring) set on the power line acts, please turn on the power supply of the servo unit after eliminating the cause. In addition,

please replace or repair the servo unit and check the wiring to eliminate the cause of the action of the safety device.

Otherwise, it may cause fire, electric shock or injury.



Warning

- When the power is restored after a temporary power failure, it may restart suddenly. Please use a mechanical design that ensures that personal safety is not endangered when restarting. Otherwise, it may cause injury.



Attention

- When an alarm occurs, please eliminate the cause of the alarm first to ensure safety. Then perform an alarm reset or turn the power back on to start operation again.

Otherwise, it may cause injury or mechanical damage.

- If an alarm reset is performed with the servo ON signal input to the servo unit, it may restart suddenly. Make sure that the servo is OFF and that it is safe before performing an alarm reset.

Otherwise, it may cause injury or mechanical damage.

- Be sure to connect a solenoid contactor between the main circuit power supply and the main circuit power terminal of the servo unit, so that the main circuit power supply side of the servo unit is designed to cut off power.

If the servo unit fails to connect the solenoid contactor, the continuous flow of high current may cause a fire.

- When an alarm occurs, disconnect the main circuit power.

Otherwise, the regenerative resistor may overheat and cause a fire due to a regenerative transistor failure, etc.

- Please configure the leakage circuit breaker for both overload and short circuit protection, or the leakage circuit breaker for ground short circuit protection combined with the circuit breaker for wiring.

Otherwise, it will cause servo unit failure or fire in case of short circuit to ground.

- When the power is cut off or abnormally stopped, the safety cannot be ensured by the brake of the servo motor in the dangerous condition of moving under the action of external force (gravity, etc.). In this case, be sure to install an external brake structure to ensure safety.

■ Precautions for Disposal

Notice

- When disposing of this product, please dispose of it as general industrial waste. However, please take into consideration the regulations of each municipality and the laws of each country, and take measures such as labeling and notification of the final product as necessary.

■ General Precautions

Notice

- The illustrations in this manual are representative examples or conceptual diagrams. It may be different from the actual wiring, circuits and physical objects.
- In order to illustrate the detailed parts of the product, the product illustrations in this manual are depicted without the outer cover or safety protection body. When using the product, be sure to install the cover or safety protection body in its original position before using it.
- If you need to obtain a new copy of this manual due to damage or loss, please contact our agent or the nearest branch office listed on the back cover. Please inform us of the information number of this manual when contacting us.
- This manual may be changed from time to time due to product improvements, changes in specifications, or to improve the convenience of using this manual.
After the change, the data number of this manual will be updated and issued as a new version.
- We do not guarantee the quality of products that have been modified by the customer. We are not responsible for any injury or damage caused by the modification of the product.

1.2 Series Introduction

SD700 series servo drives are mainly used for the occasion of high speed, high frequency and high positioning accuracy. The servo unit can maximize the performance of the machine in the shortest time, which can improve the production efficiency. SD700 servo drive not only support PROFINET, EtherCAT, MECHATROLINK-II, MECHATROLINK-III, CANopen, RS-485 and other field bus in the market, but also has a full closed loop, electronic CAM, flying shear, gantry synchronization and other non-standard application functions, through USB can be connected to the PC for debugging, convenient and fast.

1.3 Name of Each Part of the Servo Drive

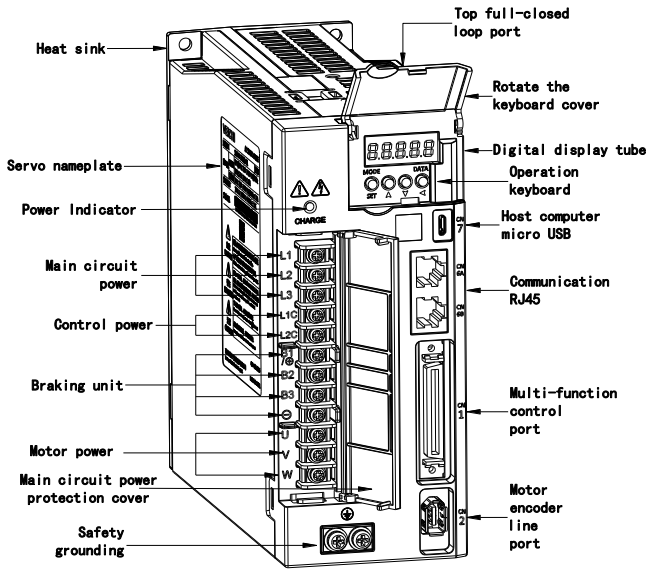

1.4 Basic Information of Servo Drive

1.4.1 Installation Dimensions

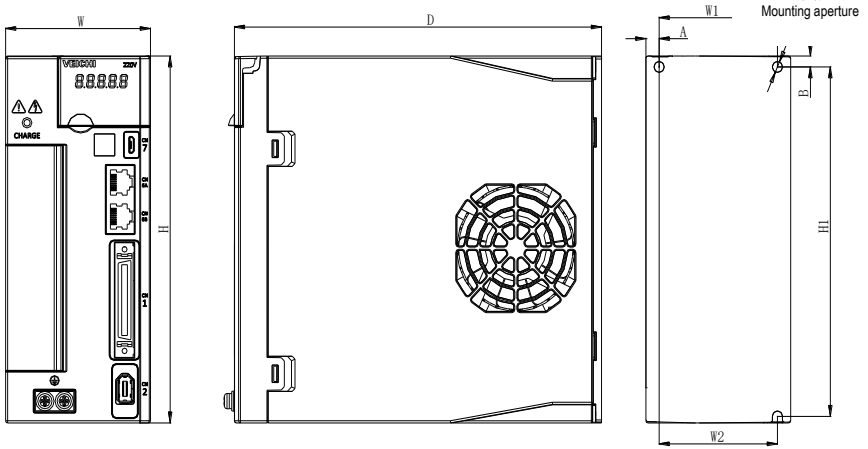

Size	Model (SD700-)	Allover size(mm)			Installation size(mm)						Mounting aperture	Weight (kg)
		W	H	D	W1	W2	H1	H2	A	B		
A	1R1A-**	45	168	170	\	20	160	\	7.5	5	2-M4	1.0
	1R8A-**											1.0
	3R3A-**											1.0
B	5R5A-**	71	168	180	58	58	160	\	6.5	5	3-M4	1.4
	7R6A-**											1.4
	9R5A-**											1.4
	2R5D-**											1.4
	3R8D-**											1.4
C	120A-**	92.5	188	182	82.5	75	180	\	5	5	3-M4	2.1
	160A-**											2.1
	6R0D-**											2.1
	8R4D-**											2.1
	110D-**											2.1
D	170D-**	120	260	210	100	84.5	250	236	\	\	4-M5	5.5
	240D-**											5.5
	300D-**											5.5

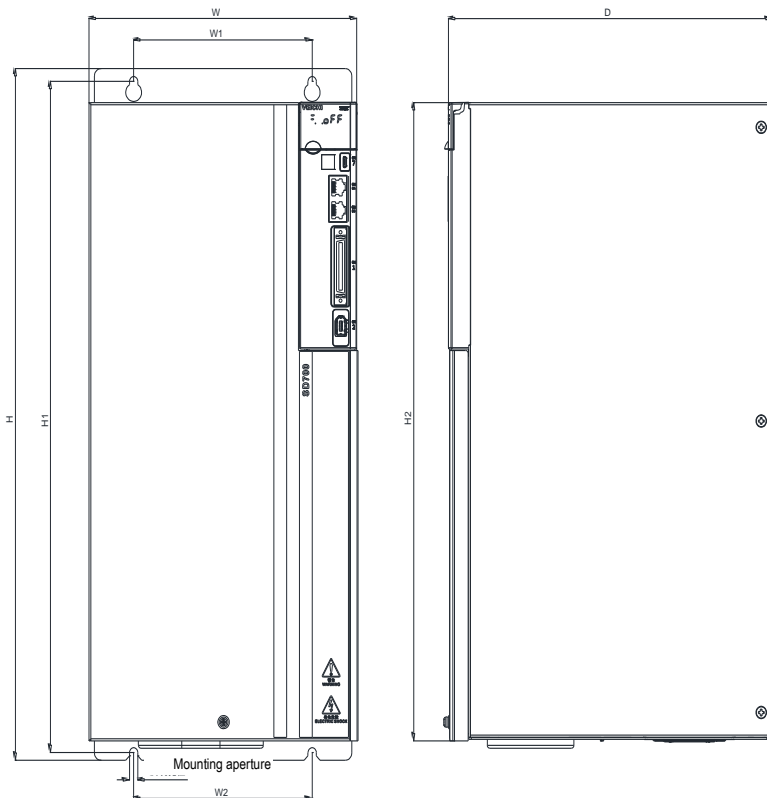

Size	Model (SD700-)	Allover size(mm)			Installation size(mm)				Mounting aperture	Weight (kg)
		W	H	D	W1	W2	H1	H2		
E	500D-**	210	471	254	140	140	457	434. 5	4-M6	15.0
	600D-**									15.0

1.4.2 Installation Way

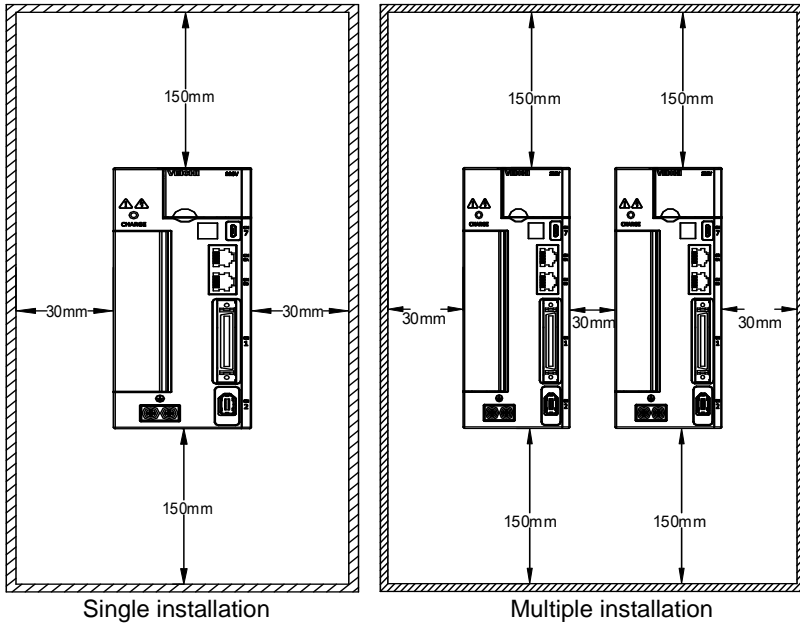

To ensure effective cooling through fans and natural convection, leave enough space around the driver for heat dissipation during installation. To ensure good heat dissipation effect, install a fan above the cabinet where the driver is installed to draw air outward. Ensure that the heat dissipation duct in the cabinet is the air inlet under the cabinet and the air outlet above the cabinet.

1.4.3 Specifications and Electric Parameters



VEICHI

MODEL: SD700-9R5A-PA

INPUT: 3PH 200~240V 50/60Hz 5.2A

OUTPUT: 3PH 0~input 0~500Hz 9.5A

IPX0  **9120121004N12357920**





Protection class Class I



危险

DANGER



警告

WARNING



注意

CAUTION

请务必按照使用说明书的指示操作。
Must read the instruction manual before operation.

本产品没有内置电机过热保护回路。
This product has no built-in motor overheat protection circuit.

断电10分钟内，请勿触摸电源端子部位，有触电危险。
Within 10 minutes of power off, do not touch the power terminals, there is a risk of electric shock.

为了防止触电，必须连接好地线。
To prevent electric shock, the ground wire must be connected.

请勿触摸散热器，有烫伤的危险。
Do not touch the heatsink, there is a risk of scalding.

苏州伟创电气科技股份有限公司
MADE IN CHINA

Suzhou Veichi Electric Co., Ltd.

Scan the QR code to download the electronic version of detailed manual.

Specification	1R1A	1R8A	3R3A	5R5A	7R6A	9R5A	2R5D	3R8D
Size	A			B				
Continuous output current /Arms	1.1	1.8	3.3	5.5	7.6	9.5	2.5	3.8
Maximum output current /Arms	3.9	6.3	11.6	16.5	22.8	23.8	7.5	11.4
Specification	120A	160A	6R0D	8R4D	110D	170D	240D	300D
Size	C					D		

Continuous output current /Arms	12.0	16.0	6.0	8.4	11.0	17.0	24.0	30.0
Maximum output current /Arms	36.0	40.0	18.0	25.2	27.5	42.5	60.0	70.0
Specification	500D	600D						
Size	E							
Continuous output current /Arms	50	60						
Maximum output current /Arms	115	120						

1.4.4 Basic specifications

Item		Specification
Drive method		IGBT PWM control sine wave current drive mode
Feedback	Rotary servo motor	Serial encoder: 17-bit, 23-bit absolute encoder
	Linear servo	Incremental linear encoder, parallel signal
Environmental conditions	Ambient temperature	-5°C~50°C (-5°C~40°C doesn't require derating, use derating when temperature exceeds 40°C, and 2% derating for every 1°C increase)
	Storage temperature	-20°C~85°C
	Ambient humidity	95% RH or less (no freezing, condensation)
	Storage humidity	95% RH or less (no freezing, condensation)
	Vibration resistance	4.9m/s ²
	Shock resistance	19.6m/s ²
	Protection level	IPX0
	Cleanliness	Non-corrosive gas, flammable gas, water, oil, and chemical splashes. Environments with less dust, salt, and metal powder
	Altitude	1000m or less (1000m~2000m, it is necessary to lower the rated value)
	Overvoltage class	III
	Protection class	Class I
	Pollution level	Level 2
	Grid power supply type	TN/TT
Other	Free of static electricity, strong electromagnetic fields, magnetic fields or exposure to radioactivity	
Applicable standard		EN/IEC61800-5-1, EN/IEC61800-3
Installation type		Base mounting type Standard

		Rack mounting type	Need accessories
Performance	Speed control range		1:5000 (The lower limit of the speed control range must be lower than the point at which the rated torque does not cause the servo motor to stop)
	Speed volatility	Load fluctuation	$\pm 0.01\%$ of rated speed (load fluctuation: 0% ~ 100%)
		Voltage fluctuation	$\pm 0.01\%$ of rated speed (voltage fluctuation: $\pm 10\%$)
		Temperature fluctuation	$\pm 0.1\%$ of rated speed (temperature fluctuation: 25°C \pm 25°C)
	Torque control accuracy (reproducibility)		$\pm 1\%$
	Soft start time setting		0s ~ 30s (Can be set individually for acceleration and deceleration)
Item		Specification	
Input and output signal	Encoder divided pulse output		Phase A, Phase B, Phase C: Linear Drive Output C phase: Collector open circuit output Number of divided pulses: any setting ratio
	Sequence input signal	Fixed input	Operating voltage range: DC5 V \pm 5% Input points: 1 point Encoder absolute value data requires input (SEN) signal
		Assignable input signal	Operating voltage range: DC24V \pm 20% Input points: 9 points Input method: common collector input, common emitter input <ul style="list-style-type: none"> • Servo ON (/S-ON) • Positive limit (P-OT), negative limit (N-OT) • Alarm Clear (/ALM-RST) • Manual PI-P Control (/P-CON) • Torque limit switching (/TLC) • Motor rotation direction switching input (/SPD-D) signal • Internal set speed switching (/SPD-A, /SPD-B) • Control mode selection (/C-SEL) • Zero clamping (/ZCLAMP) • Reference pulse inhibit (/INHIBIT) • Gain selection (/G-SEL) • Reference pulse input multiplication switching (/PSEL) (Assignable signals and change positive/negative logic. More details refer to chapter 3.8)
	Sequential output signal	Fixed output	Operating voltage range: DC5V ~ DC30V Output points: 1 point Output signal: servo alarm (ALM)
		Assignable output signal	Operating voltage range: DC5V ~ DC30V Output points: 3 points (3 points, output mode: optocoupler output (isolated)) <ul style="list-style-type: none"> • Positioning completed (/COIN) • Speed consistent detection (/V-CMP) • Rotation detection (/TGON)

			<ul style="list-style-type: none"> • Servo ready (/S-RDY) • Torque limit detection (/CLT) • Speed limit detection (/VLT) • Brake (/BK) • Warning (/WARN) • Positioning near (/NEAR) • Reference pulse input multiplication switching output (/PSELA) (Assignable signals and change positive/negative logic. More details refer to chapter 3.9)	
Item			Specification	
Communication function	Bus communication (CN6)	RS-485	Standard	
		CAN	Optional	
		M-II	Optional	
		M-III	Optional	
		PROFINET	Optional	
		EtherCAT	Optional	
	USB communication (CN7)	Connecting device	PC, standard, micro-USB(android USB)	
		Communication specification	Compliant with USB2.0 specification (12Mbps)	
Display function			CHARGE,8-segment LED × 5 digits	
Panel operator function			Button switch × 4	
Dynamic brake (DB)			Activated when a servo alarm or overtraveling occurs or when the power supply for the main circuit or servomotor is OFF	
Regeneration treatment			Function can be built in / external	
Overtravel (OT) prevention			Dynamic brake stop, deceleration to a stop, or free run to a stop at P-OT or N-OT	
Protective function			Over current, over voltage, under voltage, overload, regenerative fault, encoder disconnection, etc	
Accessibility			Gain adjustment, alarm recording, JOG operation, origin search, etc	
Control	Speed control	Soft start time setting		0s ~ 30s (acceleration and deceleration can be set separately)
		Input signal	Command voltage	Maximum input voltage: ±10V (motor forward rotation when positive voltage command) • Rated speed at DC6V [factory setting] Input gain setting can be varied
			Input Impedance	About 66kΩ
			Circuit Time Constant	30μs
		Internal set speed control	Direction of rotation	Use /SPD-D signal selection
			Speed selection	Use SPD-A/SPD-B signal input (1st ~ 3rd speed selection) Stop or change to other control modes when both

				sides are OFF	
Item				specification	
Control	Position control	Feedforward compensation		0% ~ 100%	
		Positioning Complete width setting		0 ~ 1073741824 Command unit	
		Input signal	Reference pulse	Reference pulse form	Choose one of the following: Symbol + pulse sequence, CW + CCW pulse sequence, Two-phase pulse sequence with 90° phase differential
				Input form	Linear drive, open collector
				Maximum input frequency	<ul style="list-style-type: none"> Line drive (differential input) Symbol + pulse sequence, CW+CCW pulse sequence: max 4Mpps Two-phase pulse sequence with 90° phase differential: 1Mpps Open collector Symbol + pulse sequence, CW+CCW pulse sequence: 200kpps Two-phase pulse sequence with 90° phase differential: 200kpps
				Reference Pulse Input Multiplication Switching	1times ~ 100 times
		Clear signal		Position error clear Support linear drive, open collector	
	Torque control	Input signal	Reference voltage	<ul style="list-style-type: none"> Maximum input voltage: ±10V (for forward torque output during positive voltage reference) Rated torque at DC3V [factory setting] Input gain setting can be varied 	
			Input Impedance	About 66kΩ	
			Circuit Time Constant	16μs	

1.5 System Diagram

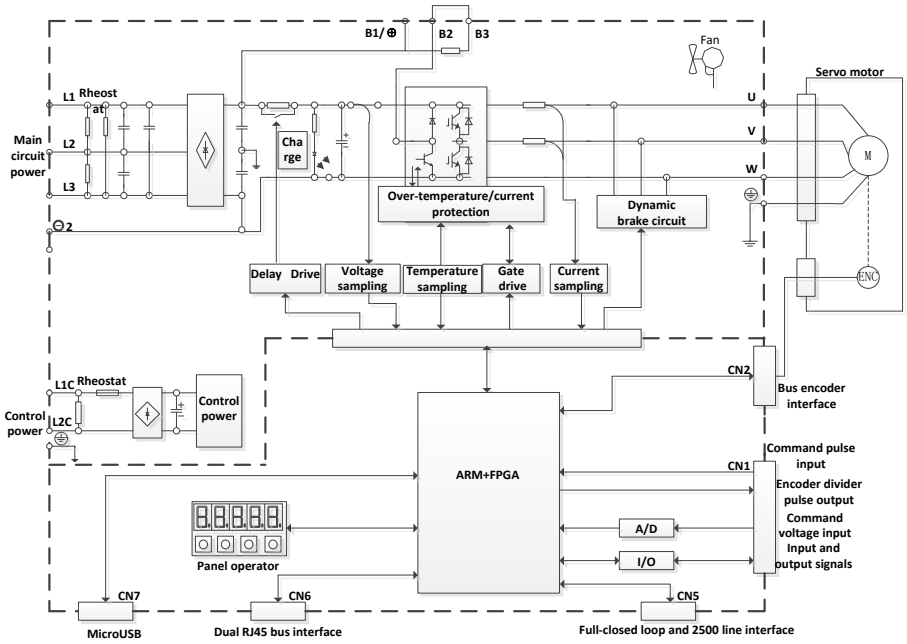

1.6 System Configuration Examples

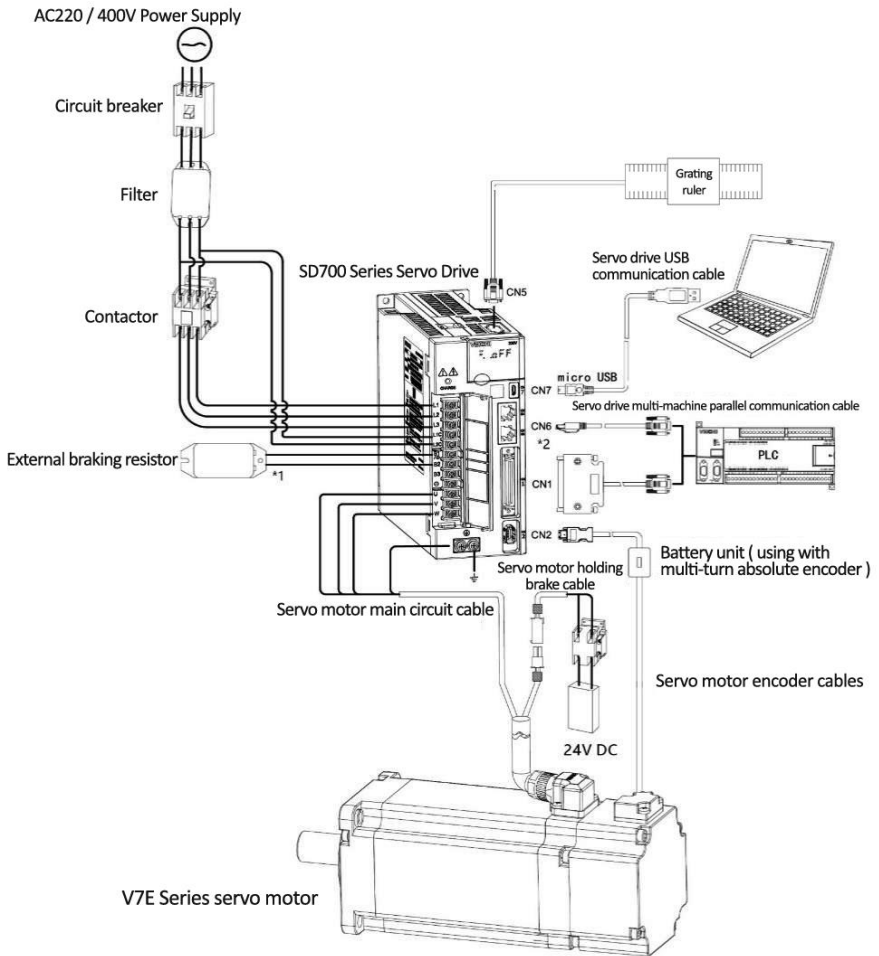

1.7 Drive Name

SD700-3R3A-PA*

A
B
C
D
E
F
G

Field ID	Field Explanation
A	SD: Servo product code
B	700: Product series
C	Current class :
	1R1:1.1A 1R8:1.8A 3R3:3.3A 5R5:5.5A 7R6:7.6A 9R5:9.5A 120:12A 160:16A 2R5:2.5A 3R8:3.8A 6R0:6A 8R4:8.4A 110:11A 170:17A 240:24A 300:30A 500:50A 600:60A 700:70A 800:80A 121:120A 171:170A 221:220A 321:320A 421:420A 521:520A
D	Input voltage class:
	A:200-240VAC; D:380-440VAC;
E	Type:
	P:pulse type; S:standard type; C:CANopen bus type; E:EtherCAT bus type M:MECHATROLINK-II bus type; L:MECHATROLINK-III bus type; N:PROFINET bus type F:Multiple I/O type
F	Supported encoder types:
	A Absolute type
G	Product management number, standard product default

Difference functions between different types:

Code	Model	Input pulse	16-bit analog value	Full closed loop	RS485	CAN open	EtherCAT	MECHATROLINK II	MECHATROLINK III	PROFINET
P	Pulse type	√	×	√	√	×	×	×	×	×
S	Standard type	√	√	√	√	√	×	×	×	×
C	CAN type	√	×	√	×	√	×	×	×	×
E	EtherCAT type	×	×	Δ	×	×	√	×	×	×
M	MECHATROLINK II type	×	×	Δ	×	×	×	√	×	×
L	MECHATROLINK III type	×	×	Δ	×	×	×	×	√	×
F	Multiple I/O type	√	×	Δ	×	×	×	×	×	×
N	PROFINET	×	×	Δ	×	×	×	×	×	√

	type								
--	------	--	--	--	--	--	--	--	--

*1.M-II type refers to the servo unit interface specification for MECHATROLINK-II communication command type

*2.M-III type refers to the servo unit interface specification for MECHATROLINK-III communication command type

Note: Pulse and CANopen servo is standard configured with 12 bit analog;

△ is optional configuration; √ is standard configuration; × is not configured.

1.8 Maintenance and Inspection of Servo Drive

The servo system is made up of many parts. The equipment performs its functions only when all the parts work properly. In mechanical parts and electronic parts, some parts need to be maintained depending on the conditions of use. It must be regularly checked or replaced according to the service-time to ensure that the servo motor and servo drive can operate normally for a long time.

1.8.1 Inspection of Servo Motor

Since the AC servo motor does not have the electric brush so that only a simple daily maintenance is required. The maintenance period in the table is a rough standard. Please judge and determine the most appropriate time for repair according to the conditions of use and use environment.

Inspect items	Inspect time	The essentials of inspection and maintenance	Notes
Vibration and sound	every day	Tactile and auditory judgments	No increase compared to usual
Appearance overhaul	According to the insult	Erasing with a cloth or cleaning with an air gun	-
Insulation resistance measurement	At least once a year	Disconnect the servo system and measure the insulation resistance with a 500V megger Resistance value exceeding 10MΩ is normal	When it is 10MΩ or less, please contact our maintenance department
Replacement of oil seals	At least once every 5,000 hours	Please contact our agents or technical support	Only servo motor with oil seal
Comprehensive maintenance	At least once every 20,000 hours or 5 years		-

1.8.2 Inspection of Servo Drive

Although the servo drive does not require daily inspections, it should be Inspection more than once a year.

Maintenance	Inspect time	The essentials of inspection and maintenance	Notes
Appearance maintenance	At least once a year	No garbage, dust, oil traces, etc	Erasing with a cloth or cleaning with an air

			gun
Loose screws		Wiring board, connector mounting screws and so on must not loosen	Please tighten

1.8.3 Approximate Standards for Changing Internal Parts of Servo Drive

Electrical and electronic parts are subject to mechanical wear and aging. To ensure safety, please do regular inspections. In addition, please refer to the following table for the standard number of years of replacement, and contact our agency or sales office. After the inspection, we will judge whether we need to replace the parts. The servo drive serviced by our company has its user parameters adjusted back to the factory settings. Be sure to reset the user parameters before use by yourself.

Parts' name	Standard replacement period	Conditions of use
Cooling fan	4 years~5 years	Ambient temperature:annual average 30°C Load rate: 80% or less Operating rate: 20 hours or less/day
Smoothing capacitor	7 years~8 years	
Relay	According to actual use conditions	
Aluminum electrolytic capacitors on printed circuit boards	5 years	

1.8.4 Precautions during Operation and Running

Attention
<p>Install the machine and before starting operation, perform the switch and parameter settings appropriate to the machine.</p> <p>If you operate the machine without setting, it may cause accidental operation, malfunction, or personal injury.</p> <ul style="list-style-type: none"> ● Do not make extreme changes to the parameter settings. Otherwise, it may cause unstable operation, mechanical damage or injury. ● To avoid accidents, install a limit switch or stopper at the end of the movable part of the machine. Otherwise, it may cause damage or injury to the machine. ● The test run should be performed when the servo motor is fixed and disconnected from the machine. Otherwise, injury may occur.

Operating Qualifications

This product must be operated by trained professionals. Moreover, the operator must be trained in professional skills, familiar with the installation, wiring, operation and maintenance of the equipment, and properly respond to various emergencies that occur during use.

Safety instructions

Warning signs are presented for your safety and are measures to prevent injury to the operator and damage to the product and associated systems. Please read this manual carefully before use, and strictly follow the safety rules and warning signs in this manual.

1.9 Motor Name

VM7-L08A-1R030-D1*

A B C D E F G H I

Field ID	Field Explanation				
A	Series: V7E VM7 VM5				
B	Inertia: L:Low inertia M:midium inertia H:High inertia				
C	Flange: 04:40mm 11:110mm 06:60mm 13:130mm 08:80mm 18:180mm 10:100mm 20:200mm 26:263mm				
D	Rated voltage: A:220VAC; D:400VAC;				
E	Rated power: R05:50W R10:100W R20:200W R40:400W R60:600W R75:750W R85:850W 1R0:1.0kW 1R2:1.2kW 1R3:1.3kW 1R5:1.5kW 1R8:1.8kW 2R0:2.0kW 2R3:2.3kW 2R6:2.6kW 2R9:2.9kW 4R4:4.4kW 5R5:5.5kW 7R5:7.5kW 011:11kW 015:15kW 020:20kW 022:22kW 030:30kW 037:37kW 045:45kW 055:55kW 075:75kW 090:90kW 110:110kW 150:150kW 200:200kW				
F	Rated speed(RPM): 15:1500 20:2000 25:2500 30:3000				
G	Type of encoder: D:23 bit multi-turn absolute encoder(optical) Q:17 bit sigle-turn absolute encoder(magnetic) R:17 bit multi-turn absolute encoder(magnetic) S: 20 bit multi-turn absolution optical cross shaft encoder				
H	Type of shaft: 1: Key shaft; with threaded hole; oil seal; with out brake 2: Key shaft; with threaded hole; oil seal; with brake				
I	Internal management number:A General shaft (Standard omission);B Same as Yaskawa shaft;Z Non-standard shaft (Letter replaceable)				

1.10 Dimension of Motors

40 Flange motors (Unit:mm):

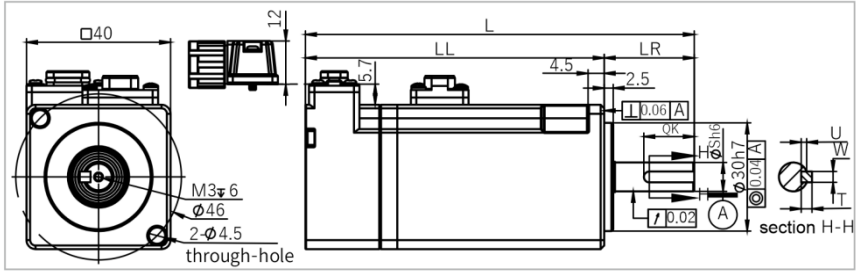

Model	L	LL	LR	S	QK	U	W	T
V7E-L04A-R1030-□1	108	83	25	8	14	1.5	3	3
V7E-L04A-R1030-□2	134	109	25	8	14	1.5	3	3

60 Flange motors (Unit:mm):

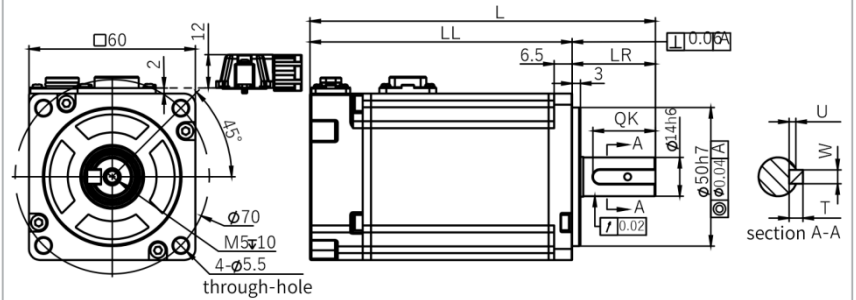

Model	L	LL	LR	S	QK	U	W	T
V7E-L06A-R2030-□1	105.5	75.5	30	14	22.5	2.5	5	5
V7E-L06A-R2030-□2	136.5	106.5	30	14	22.5	2.5	5	5
V7E-L06A-R4030-□1	124.5	94.5	30	14	22.5	2.5	5	5
V7E-L06A-R4030-□2	155.5	125.5	30	14	22.5	2.5	5	5
V7E-M06A-R4030-□1	134.5	104.5	30	14	22.5	2.5	5	5
V7E-M06A-R4030-□2	165.5	135.5	30	14	22.5	2.5	5	5
V7E-L06A-R6030-□1	143.5	113.5	30	14	22.5	2.5	5	5
V7E-L06A-R6030-□2	174.5	144.5	30	14	22.5	2.5	5	5

80 Flange motors: (Unit:mm):

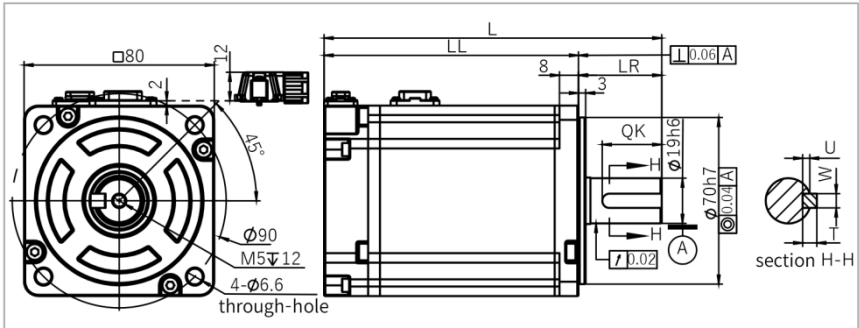

Model	L	LL	LR	S	QK	U	W	T
V7E-L08A-R7520-□1L	156	121	35	19	25	3	6	6
V7E-L08A-R7520-□2L	188	153	35	19	25	3	6	6
V7E-L08A-R7530-□1L	142	107	35	19	25	3	6	6
V7E-L08A-R7530-□2L	174	139	35	19	25	3	6	6
V7E-M08A-R7530-□1L	152	117	35	19	25	3	6	6
V7E-M08A-R7530-□2L	184.5	149.5	35	19	25	3	6	6
V7E-L08A-R7530-□1	142	107	35	19	25	3	6	6
V7E-L08A-R7530-□2	174	139	35	19	25	3	6	6
V7E-M08A-R7530-□1	152	117	35	19	25	3	6	6
V7E-M08A-R7530-□2	184.5	149.5	35	19	25	3	6	6
V7E-L08A-1R030-□1	156	121	35	19	25	3	6	6
V7E-L08A-1R030-□2	188	153	35	19	25	3	6	6

110 Flange motors: (Unit:mm):

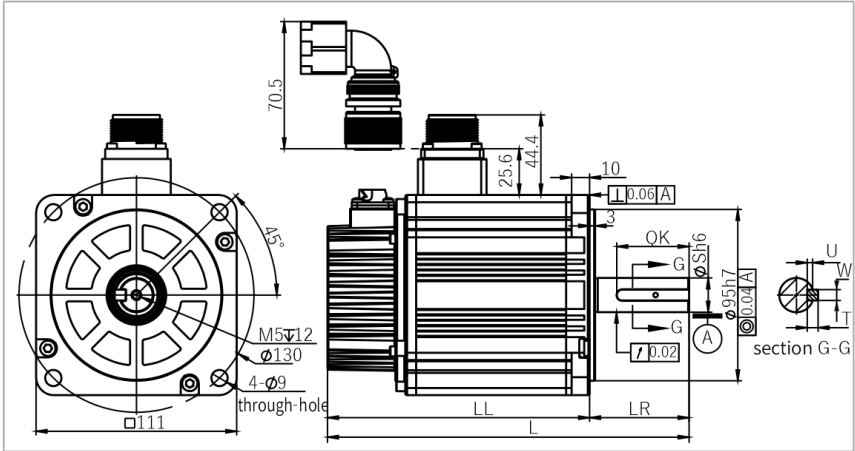

Model	L	LL	LR	S	QK	U	W	T
V7E-M11A-1R230-□1	190	135	55	19	40	3	6	6
V7E-M11A-1R230-□2	221.2	166.2	55	19	40	3	6	6
V7E-M11A-1R530-□1	200	145	55	19	40	3	6	6
V7E-M11A-1R530-□2	231.2	176.2	55	19	40	3	6	6
V7E-M11A-1R830-□1	210	155	55	19	40	3	6	6
V7E-M11A-1R830-□2	241.2	186.2	55	19	40	3	6	6

130 Flange motors: (Unit:mm):

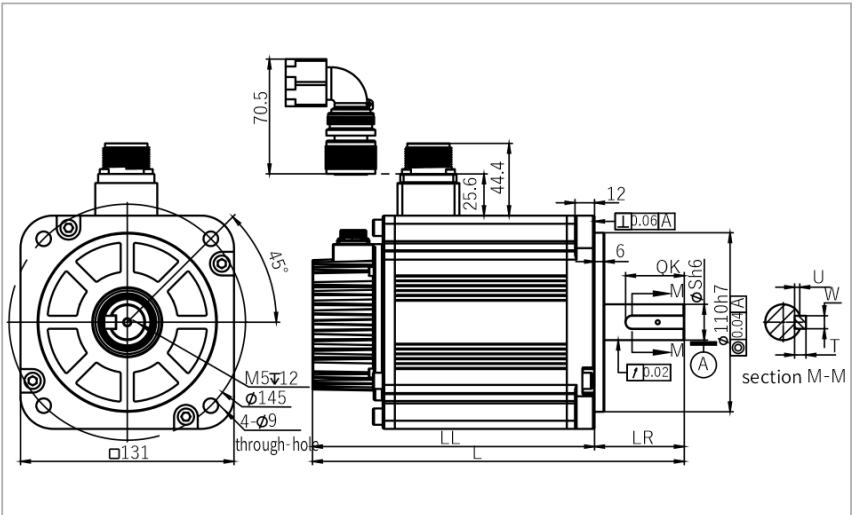

Model	L	LL	LR	S	QK	U	W	T
V7E-M13A-R8515-□1	193	138	55	22	36	3.2	8	7
V7E-M13A-R8515-□2	221.2	166.2	55	22	36	3.2	8	7
V7E-M13A-1R020-□1	193	138	55	22	36	3.2	8	7
V7E-M13A-1R020-□2	221.2	166.2	55	22	36	3.2	8	7
V7E-M13A-1R315-□1	208	153	55	22	36	3.2	8	7
V7E-M13A-1R315-□2	236.2	181.2	55	22	36	3.2	8	7
V7E-M13A-1R520-□1	208	153	55	22	36	3.2	8	7
V7E-M13A-1R520-□2	236.2	181.2	55	22	36	3.2	8	7
V7E-M13A-1R815-□1	228	173	55	22	36	3.2	8	7
V7E-M13A-1R815-□2	256.2	201.2	55	22	36	3.2	8	7
V7E-M13A-2R020-□1	228	173	55	22	36	3.2	8	7
V7E-M13A-2R020-□2	256.2	201.2	55	22	36	3.2	8	7
V7E-M13A-2R315-□1L	258	203	55	22	36	3.2	8	7
V7E-M13A-2R315-□2L	286.2	231.2	55	22	36	3.2	8	7
V7E-M13A-3R020-□1	258	203	55	22	36	3.2	8	7
V7E-M13A-3R020-□2	286.2	231.2	55	22	36	3.2	8	7
V7E-M13D-R8515-□1	193	138	55	22	36	3.2	8	7
V7E-M13D-R8515-□2	221.2	166.2	55	22	36	3.2	8	7
V7E-M13D-1R020-□1	193	138	55	22	36	3.2	8	7
V7E-M13D-1R020-□2	221.2	166.2	55	22	36	3.2	8	7
V7E-M13D-1R315-□1	208	153	55	22	36	3.2	8	7
V7E-M13D-1R315-□2	236.2	181.2	55	22	36	3.2	8	7
V7E-M13D-1R520-□1	208	153	55	22	36	3.2	8	7
V7E-M13D-1R520-□2	236.2	181.2	55	22	36	3.2	8	7
V7E-M13D-1R815-□1	228	173	55	22	36	3.2	8	7
V7E-M13D-1R815-□2	256.2	201.2	55	22	36	3.2	8	7
V7E-M13D-2R020-□1	228	173	55	22	36	3.2	8	7
V7E-M13D-2R020-□2	256.2	201.2	55	22	36	3.2	8	7
V7E-M13D-2R315-□1L	258	203	55	22	36	3.2	8	7
V7E-M13D-2R315-□2L	286.2	231.2	55	22	36	3.2	8	7
V7E-M13D-3R020-□1	258	203	55	22	36	3.2	8	7
V7E-M13D-3R020-□2	286.2	231.2	55	22	36	3.2	8	7
V7E-M13A-R8515-□1B	193	138	55	19	40	3.1	6	6
V7E-M13A-R8515-□2B	221.2	166.2	55	19	40	3.1	6	6
V7E-M13A-1R815-□1B	228	173	55	24	36	3.3	8	7
V7E-M13A-1R815-□2B	256.2	201.2	55	24	36	3.3	8	7
V7E-M13D-R8515-□1B	193	138	55	19	40	3.1	6	6
V7E-M13D-R8515-□2B	221.2	166.2	55	19	40	3.1	6	6
V7E-M13D-1R815-□1B	228	173	55	24	36	3.3	8	7
V7E-M13D-1R815-□2B	256.2	201.2	55	24	36	3.3	8	7

180 Flange motors: (Unit-mm):

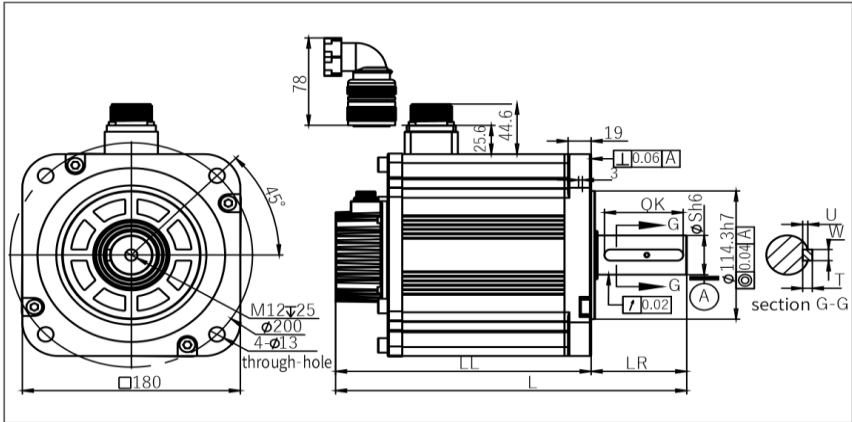

Model	L	LL	LR	S	QK	U	W	T
V7E-M18A-2R915-□1	266	187	79	35	65	4.3	10	8
V7E-M18A-2R915-□2	307.5	228.5	79	35	65	4.3	10	8
V7E-M18A-4R415-□1	290	211	79	35	65	4.3	10	8
V7E-M18A-4R415-□2	331.5	252.5	79	35	65	4.3	10	8
V7E-M18D-2R915-□1	266	187	79	35	65	4.3	10	8
V7E-M18D-2R915-□2	307.5	228.5	79	35	65	4.3	10	8
V7E-M18D-2R915-□1H	266	187	79	35	65	4.3	10	8
V7E-M18D-2R915-□2H	307.5	228.5	79	35	65	4.3	10	8
V7E-M18D-4R415-□1	290	211	79	35	65	4.3	10	8
V7E-M18D-4R415-□2	331.5	252.5	79	35	65	4.3	10	8
V7E-M18D-4R415-□1H	290	211	79	35	65	4.3	10	8
V7E-M18D-4R415-□2H	331.5	252.5	79	35	65	4.3	10	8
V7E-M18D-5R515-□1	325.5	246.5	79	35	65	4.3	10	8
V7E-M18D-5R515-□2	367	288	79	35	65	4.3	10	8
V7E-M18D-5R515-□1H	325.5	246.5	79	35	65	4.3	10	8
V7E-M18D-5R515-□2H	367	288	79	35	65	4.3	10	8
V7E-M18D-7R515-□1	372.5	293.5	79	35	65	4.3	10	8
V7E-M18D-7R515-□2	414	335	79	35	65	4.3	10	8
V7E-M18D-7R515-□1H	372.5	293.5	79	35	65	4.3	10	8
V7E-M18D-7R515-□2H	414	335	79	35	65	4.3	10	8
V7E-M18D-5R515-□1BH	359.5	246.5	113	42	96	4.2	12	10
V7E-M18D-5R515-□2BH	401	288	113	42	96	4.2	12	10
V7E-M18D-7R515-□1BH	406.5	293.5	113	42	96	4.2	12	10
V7E-M18D-7R515-□2BH	448	335	113	42	96	4.2	12	10

200 Flange motor: (Unit:mm):

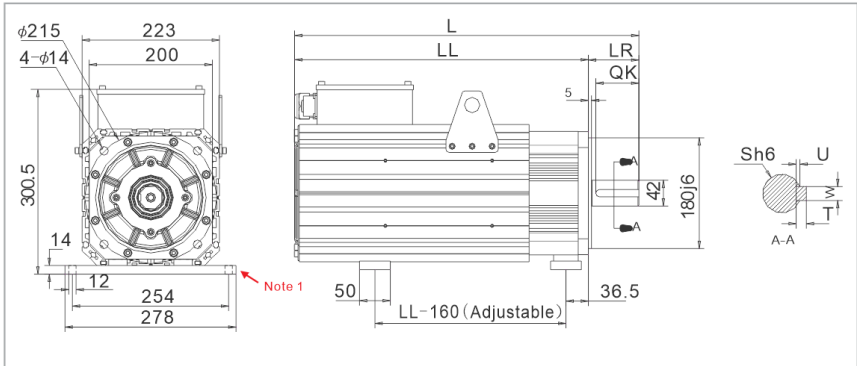

Model	L	LL	LR	S	QK	U	W	T
V7E-M20D-01115-□1FN	451	369	82	42	4	12	8	70
V7E-M20D-01515-□1FN	488	406	82	42	4	12	8	70
V7E-M20D-02015-□1FN	560	478	82	42	4	12	8	70
V7E-M20D-02215-□1FN	607	525	82	42	4	12	8	70

Note 1: The foot plate of 200mm flange motor (optional).

Model code: S18 Material code: 6010000008

263 Flange motors: (Unit:mm):

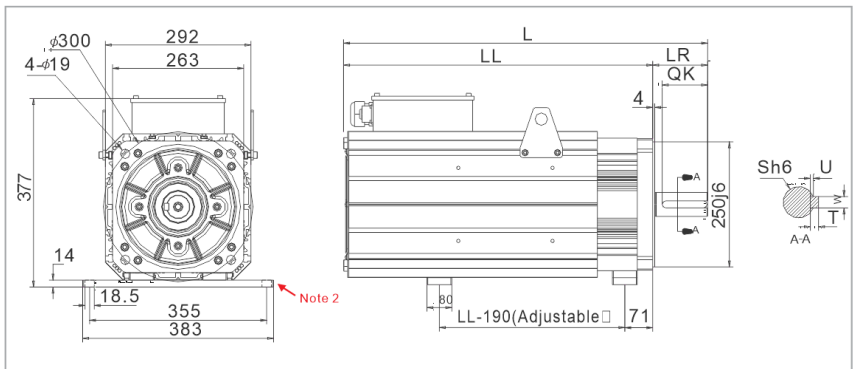

Model	L	LL	LR	S	QK	U	W	T
V7E-M26D-03015-□1FN	640	530	110	48	4.5	14	9	90
V7E-M26D-03715-□1FN	684	574	110	48	4.5	14	9	90

2 Panel Operation

2.1 Basic Operation

2.1.1 Keys' Names and Functions of the Panel Operator

The panel operator consists of display and keys.

The panel operator could display status, operate the accessory functions, set parameters and monitoring the servo drive.

The panel operator keys' names and functions are shown as below:

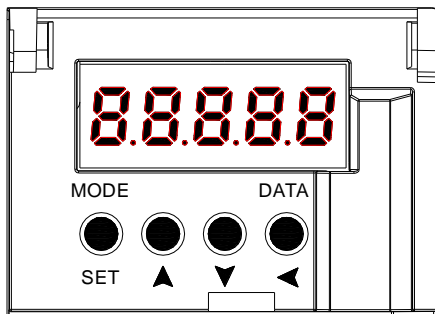

Keys	Functions
MODE/SET key	Shift the function modes
	Confirm parameter settings
	Operate the accessory functions
▲ UP key	Select parameters up or increase the value, switch between high, medium, and low segment values in multiple segment display parameters
▼ DOWN key	Select parameters down or decrease the value, switch between high, medium, and low segment values in multiple segment display parameters
DATA/SHIFT key	Press and hold the DATA/SHIFT key for about 1 second to enter or exit
	Short press to move to the left one (when flashing)



Press and hold the UP and DOWN keys simultaneously to reset the servo alarm. Before resetting the servo alarm, be sure to remove the cause of the alarm, otherwise a safety accident may occur.

2.1.2 Functions Switch

Press the MODE/SET key, the function will be switched like this shown as below:

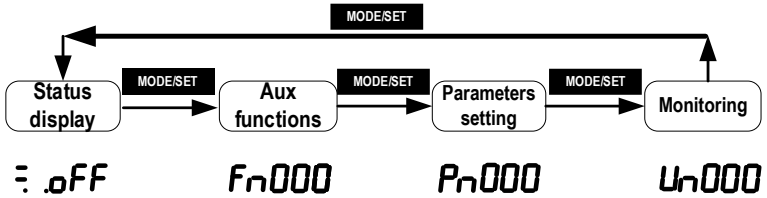

2.1.3 Status Display

The method of judging the status display is as follows:

Display	Meaning	Display	Meaning
<i>oFF</i>	Means that the drive is OFF.	<i>not</i>	Means that the input signal (N -OT) is an open circuit.
<i>on</i>	Means that the drive is ON.	<i>C90</i>	Flashing displays fault code, more details on the "fault code".
<i>Pot</i>	Means that the input signal(P-OT) is an open circuit.	<i>on</i> ⬇ <i>tSt</i>	No-motor testing function displays the running status alternately, more details in this function.

Display	Meaning	Display	Meaning
<i>9B</i>	It lights on when the control power is ON and lights off when OFF.	<i>BB</i>	It lights on when the main circuit is ON and lights off when OFF.
<i>BB</i>	Speed control: speed outputs(/V-CMP) are absolutely same. Position control: it lights on when the process positioning is OK(/COIN). Torque control: it lights on all the time.	<i>BB</i>	It lights on when the rotation detection outputs(/TGON).
		<i>BB</i>	Speed control: it lights on when the speed command inputs. Position control: it lights on when the position command inputs.
<i>BB</i>	It lights on when the drive is OFF and lights off when ON.	<i>BB</i>	Torque control: it lights on when the torque command inputs. Position control: it lights on when the pulse clear signal outputs.

2.2 Operations of Auxiliary Functions (Fn group)

Auxiliary functions are about performing the settings and adjustment of the servo drive. The panel operator displays the numbers which begin with Fn.

Let's take the JOG function (Fn005) as an example to explain the operating method of the auxiliary functions:

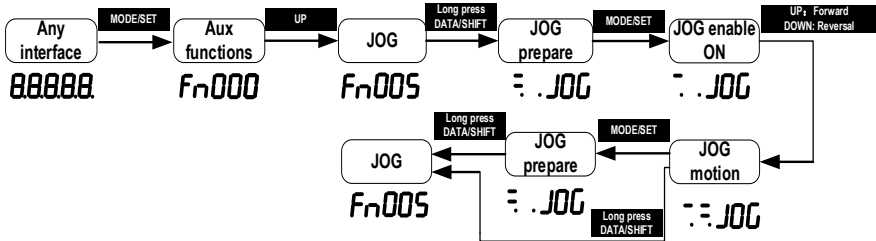

2.3 Operations of Parameter (Pn Group)

(1) When the setting range is within 5-digit numbers.

Let me introduce the parameters Pn's setting method: Take the setting method of the speed loop gain rise from 40.0 to 100.0 as an example:

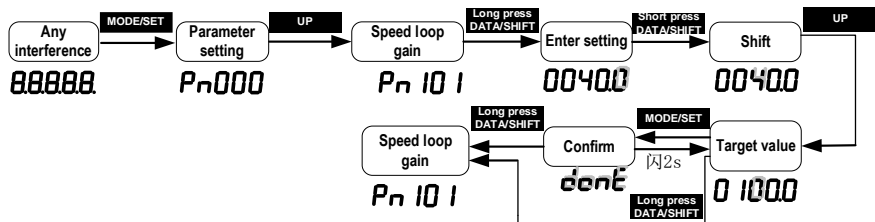

(2) When the setting range is over 6-digit numbers:

Because the panel operator could only display 5-digit number, so the setting display with 6-digit number is shown as below:

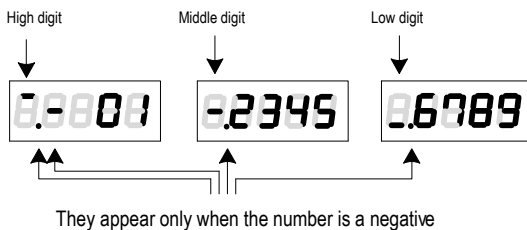

2.4 Operations of Monitoring Display Un Group

The monitor displays can be used for monitoring the reference values, I/O signal status, and servo internal status.

The panel operator displays the numbers which begin with Un, then let's take this function as an example to explain the operating method of the monitoring display: when the motor speed is 3000rpm:



If you want the monitor to automatically display related information after the servo drive is powered on, set PN003 (default 0xFFF) to a relevant value. For example, if you want the motor speed to automatically display after the drive is powered on, set PN003 to 00000 (motor speed). For details about the values of each monitoring information, see "Monitor Display".

3 Wiring and Connections

3.1 Main Circuit Wiring

3.1.1 Terminals Description

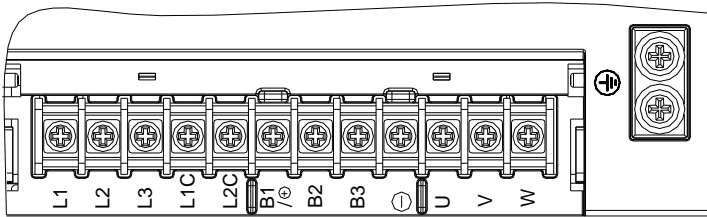

Pin No.	Signal name	Functions
1	L1 (R/L)	Main circuit power input
2	L2 (S/N)	Main circuit power input
3	L3 (T)	Main circuit power input
4	L1C	Control circuit power input
5	L2C	Control circuit power input
6	B1/+	Positive of Internal and external braking resistor Pins/ DC power supply after rectification
7	B2(PB)	Energy-consumption braking output
8	B3	Pin of internal braking resistor
9	-	Negative of DC power supply
10	U	Motor power U phase
11	V	Motor power V phase
12	W	Motor power W phase
Casing	Grounding	Safely grounding



A volume drive main circuit wiring can only be connected to a single phase (two terminals are provided), and there is no built-in brake electronics, please pay attention to the correct wiring according to the wiring label when wiring.

3.1.2 Recommended Model and Specification of Main Circuit Connection Cable

Drive input/output current specifications

Drive model SD700-*R*A-**		Rated input current(A)	Rated output current(A)	Max. output current(A)
Single-phase 220V				
SIZE A	1R1A	1.28	1.1	2.53
	1R8A	2.1	1.8	4.14
	3R3A	3.89	3.3	7.59
Three-phase 220V				
SIZE B	5R5A	3.1	5.5	12.65
	7R6A	4.2	7.6	17.48
	9R5A	5.2	9.5	21.85
SIZE C	120A	10.3	12	27.6
	160A	13.7	16	36.8
Three-phase 380V				
Size B	2R5D	2.8	2.5	5.75
	3R8D	4.18	3.8	8.74
SICE C	6R0D	8.8	6.0	13.8
	8R4D	12.4	8.4	19.32
	110D	16.2	11	25.3
SIZE D	170D	22.4	17	39.1
	240D	31.6	24	55.2
	300D	39.5	30	69
SIZE E	500D	46.7	50	115
	600D	56	60	138

Main circuit terminal connecting cable recommendation

Drive model SD700-*R*A-**			L1C, L2C		L1, L2, L3 /R 、 S、 T		PΦ、 B2、 B3、 N O、		U、 V、 W、 PE		Grounding terminal	
SIZE	Model NO.	Rated input current(A)		AWG		AWG		AWG		AWG		AWG
Single-phase 220V												
SIZE A	1R1A	1.28	2×0.82	18	3×1.31	16	3×1.31	16	3×1.31	16	2.08	14
	1R8A	2.1	2×0.82	18	3×1.31	16	3×1.31	16	3×1.31	16	2.08	14
	3R3A	3.89	2×0.82	18	3×1.31	16	3×1.31	16	3×1.31	16	2.08	14
Three-phase 220V												
SIZE B	5R5A	3.1	2×0.82	18	3×1.31	16	3×1.31	16	3×1.31	16	2.08	14
	7R6A	4.2	2×0.82	18	3×1.31	16	3×1.31	16	3×1.31	16	2.08	14
	9R5A	5.2	2×0.82	18	3×1.31	16	3×1.31	16	3×1.31	16	2.08	14
SIZE C	120A	10.3	2×0.82	18	3×3.33	12	3×3.33	12	3×3.33	12	2.08	14
	160A	13.7	2×0.82	18	3×5.27	10	3×5.27	10	3×5.27	10	5.27	10
Three-phase 380V												
Size B	2R5D	2.8	2×0.82	18	3×1.31	16	3×1.31	16	3×1.31	16	2.08	14
	3R8D	4.18	2×0.82	18	3×1.31	16	3×1.31	16	3×1.31	16	2.08	14
SICE C	6R0D	8.8	2×0.82	18	3×3.33	12	3×3.33	12	3×3.33	12	2.08	14
	8R4D	12.4	2×0.82	18	3×5.27	10	3×5.27	10	3×5.27	10	5.27	10
	110D	16.2	2×0.82	18	3×5.27	10	3×5.27	10	3×5.27	10	5.27	10
SIZE D	170D	22.4	2×0.82	18	3×8.37	8	3×8.37	8	3×8.37	8	8.37	8
	240D	31.6	2×0.82	18	3×8.37	8	3×8.37	8	3×8.37	8	8.37	8
	300D	39.5	2×0.82	18	3×16.77	5	3×16.77	5	3×16.77	5	16.77	5
SIZE E	500D	46.7	2×0.82	18	3×16.77	5	3×16.77	5	3×16.77	5	16.77	5
	600D	56	2×0.82	18	3×16.77	5	3×16.77	5	3×16.77	5	16.77	5

3.1.3 Wiring Diagram

A-volume single-phase wiring diagram

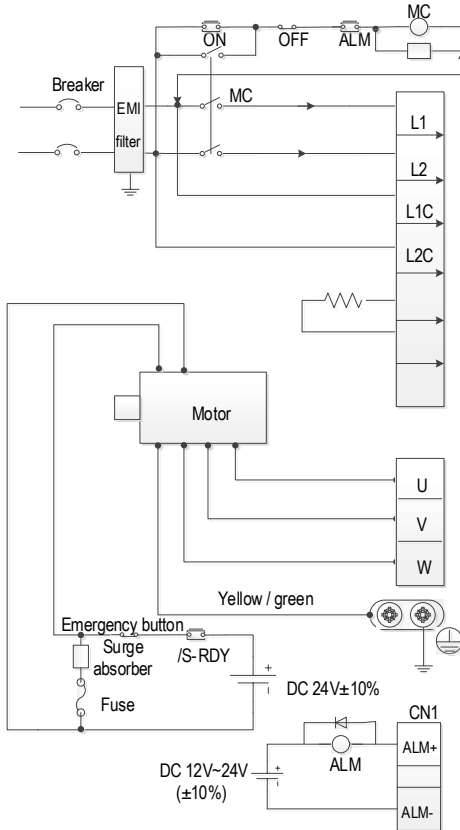

- Please make this emergency stop protection circuit.
- Electromagnetic contactor package surge absorbing device at both ends.
- 220V system input voltage range:
AC 220V(-15%)~240V(+10%)
- 400V system input voltage range:
AC 380V(-15%)~440V(+10%)
- When using an external regenerative braking resistor, connect it by the dotted line in the figure.
- Please connect the U, V, W, and output of the drive correctly according to the motor cable phase sequence of the servo motor. The wrong phase sequence will cause the drive to malfunction.
- Be sure to ground the servo drive to avoid electrical damage.
- The 24V power supply for electromagnetic braking needs to be provided by the user and must be isolated from the 12V~24V power supply for the control signal.
- Pay attention to the connection of the freewheeling diode. Reversing the positive and negative poles may damage the driver.

B/C/D-volume three-phase wiring diagram

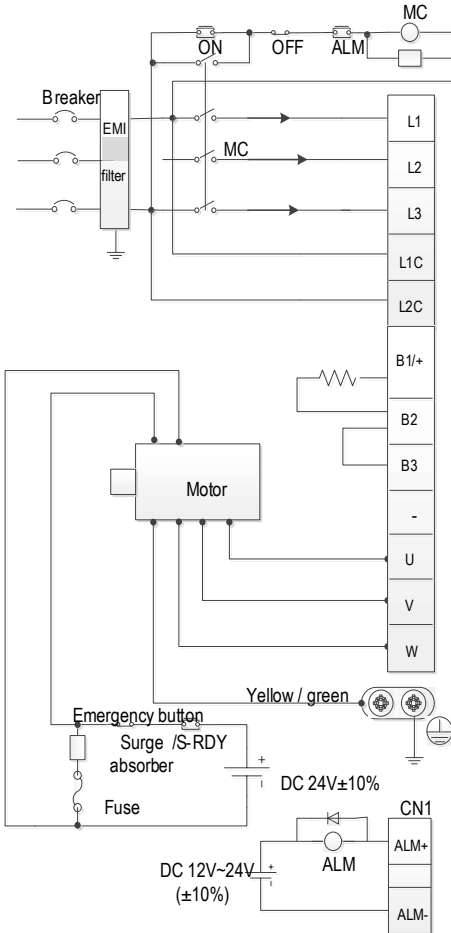

- Please make this emergency stop protection circuit.
- Electromagnetic contactor package surge absorbing device at both ends.
- 220V system input voltage range:
AC 220V(-15%)~240V(+10%)
- 400V system input voltage range:
AC 380V(-15%)~440V(+10%)
- Please connect the U, V, W, and output of the drive correctly according to the motor cable phase sequence of the servo motor. The wrong phase sequence will cause the drive to malfunction.
- Do not disconnect short wires between B2 and B3 unless using an external regenerative braking resistor.
- When using an external regenerative braking resistor, disconnect the short wiring between B2 and B3 and connect them by the dotted line in the figure.
- Be sure to ground the servo drive to avoid electrical damage.
- The 24V power supply for electromagnetic braking needs to be provided by the user and must be isolated from the 12V~24V power supply for the control signal.
- Pay attention to the connection of the freewheeling diode. Reserving the positive & negative poles may damage the drive.

E/F-volume three-phase wiring diagram

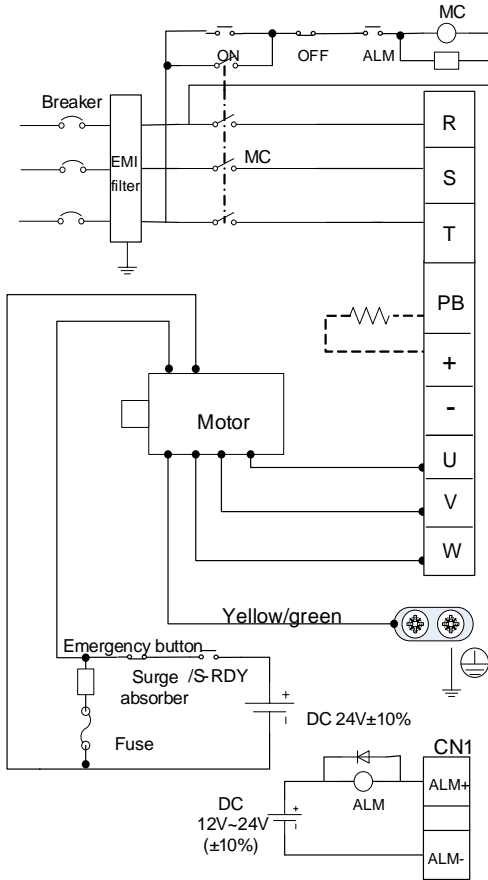

- Please make this emergency stop protection circuit.
- Electromagnetic contactor package surge absorbing device at both ends.
- 400V system input voltage range:
AC 380V(-15%)~440V(+10%)
- Please connect the U, V, W, and output of the drive correctly according to the motor cable phase sequence of the servo motor. The wrong phase sequence will cause the drive to malfunction.
- When using external regenerative resistor, connect according to the dotted line in the figure (Pb / +) .
- Be sure to ground the servo drive to avoid electrical damage.
- The 24V power supply for electromagnetic braking needs to be provided by the user and must be isolated from the 12V ~24V power supply for the control signal.
- Pay attention to the connection of the freewheeling diode. Reversing the positive and negative poles may damage the driver.

3.1.4 Main Circuit Wiring Requirements

The drive power input cable and motor cable can have strong electromagnetic interference. In order to avoid electromagnetic interference through strong interference cables and control circuits generated by long distance parallel wiring coupling. When wiring the main circuit cable and signal cable distance should be greater than 30cm. In addition, common main circuit cables are input RST line, output UVW line, DC bus and brake cables, signal cables are IO signal line, communication line and encoder line. The cables and trunking must be well connected and properly grounded. Aluminum wireways ensure that the equipment is equipotential, and that filters, drives, and motors should be well lapped to the system (mechanical or device), well protected by spraying in the installed section, and that conductive metals need to be fully contacted.

Terminal allowable wire diameter range and tightening torque table

Drive model SD700-*R*A-**			Wire diameter range	Limit tightening torque
SIZE	Model	Rated input current(A)	AWG	N*m
Single-phase 220V				
SIZE A	1R1A	1.28	12~28	/
	1R8A	2.1	12~28	/
	3R3A	3.89	12~28	/
Three-phase 220V				
SIZE B	5R5A	3.1	14~22	1.176
	7R6A	4.2	14~22	1.176
	9R5A	5.2	14~22	1.176
SIZE C	120A	10.3	10~22	1.96
	160A	13.7	10~22	1.96
Three-phase 380V				
Size B	2R5D	2.8	14~22	1.176
	3R8D	4.18	14~22	1.176
SICE C	6R0D	8.8	10~22	1.96
	8R4D	12.4	10~22	1.96
	110D	16.2	10~22	1.96
SIZE D	170D	22.4	8~20	2.45
	240D	31.6	8~20	2.45
	300D	39.5	8~20	2.45
SIZE E	500D	46.7	3~18	7.84
	600D	56	3~18	7.84

Wiring requirements

This product supports the wiring method in case of low voltage command.

- Terminals (P⊕, C, NØ) are for connecting optional parts. Do not connect these terminals to the AC power supply.
- To protect the main circuit, it is covered separately from the surface that may come into contact with it.
- Be careful not to allow other objects to enter the terminal block wiring section.
- Do not solder when using stranded core wires.
- The tightening torque of each terminal may be different, so tighten the screws according to the specified tightening torque. Use a torque driver, torque ratchet or torque wrench.
- If using an electric tool to tighten the terminal screws, use the low speed setting otherwise the terminal screws may be damaged.
- Do not tighten the terminal screws at an angle of more than 5 degrees, otherwise the terminal screws may be damaged.

3.2 Motor Power Line Connection

V7E motor 40mm flange power cable definition

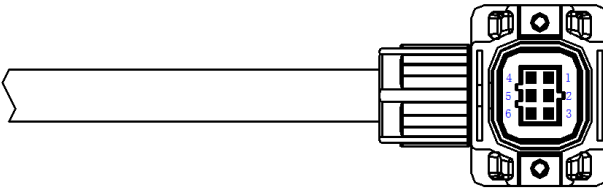

WIRE RUN LIST					
Specification	CONN.1	Color	CONN.2	CONN.3	Signal
6*0.3	U	Blue	1		U
	V	Brown	2		V
	W	Red	3		W
	PE	Yellow/Green	4		PE
		White	5	1	BAKE+
		Black	6	2	BAKE-

V7E motor 60mm/80mm flange power cable definition

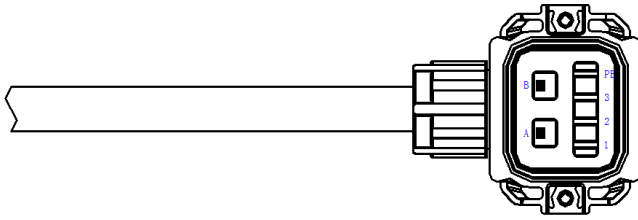

WIRE RUN LIST					
Specification	CONN.1	Color	CONN.2	CONN.3	Signal
4*0.5	U	Blue	3		U
	V	Brown	2		V
	W	Red	1		W
	PE	Yellow/Green	PE		PE
2*0.3		White	A	1	BAKE+
		Black	B	2	BAKE-

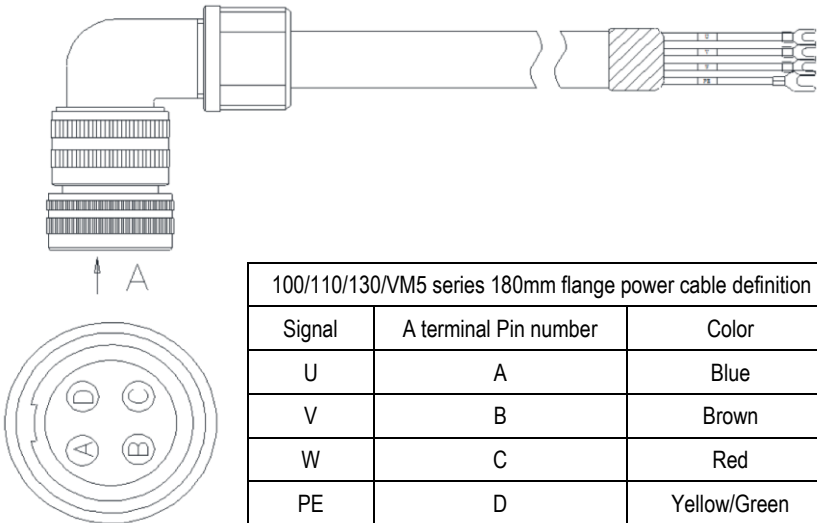

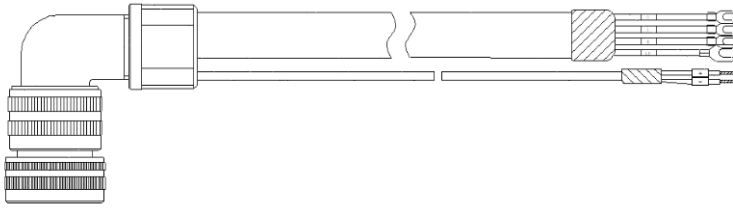

		180 flange motor power cable definition (D2M + VM7 series D2) motor with brake		
		Signal definition	Pin number	Wire core color
		U	D	Blue
		V	E	Brown
		W	F	Red
		P E	G	Yellow-green
		BAKE+	A	Red
		BAKE-	B	Black

		110 flange + 130 flange motor power cable definition motor with brake		
		Signal definition	Pin number	Wire core color
		U	F	Blue
		V	I	Brown
		W	B	Red
		P E	E	Yellow-green
		BAKE+	G	Red
		BAKE-	H	Black

3.3 CN2 Encoder Connection

V7E motor 40mm/60mm/80mm flange encoder cable definition

Drive terminal:

Motor terminal:

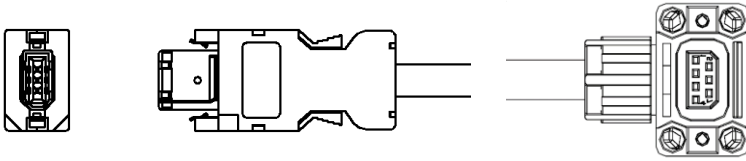

WIRE RUN LIST

Specification	CONN.1	CONN.2		Signal
	1	1		+5V
	2	2		0V
2PX24AWG	5	5		SD+
	6	6		SD-
	Iron shell	7	Shielding layer	PE+

Encoder 110mm flange and above encoder definition

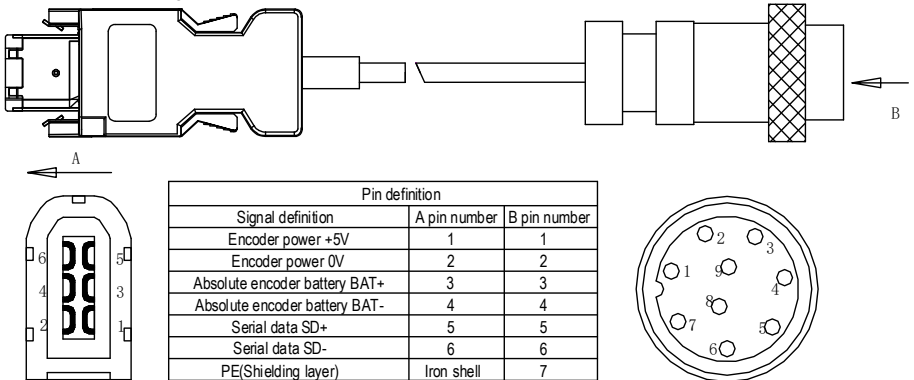

Note:

1. When welding the encoder, please pay attention to the definition of A-end and B-end pins (as shown in the table above). The encoder wire uses twisted pair shielded wire, and the shielding layers at both ends of the wire should be grounded.
2. When using the multi-turn absolute encoder, please pay attention to the positive and negative electrodes of the battery. It is recommended to use the lithium battery with rated voltage of 3.6V and rated capacity of 2.7AH.

3.4 Holding Brake Line Connection

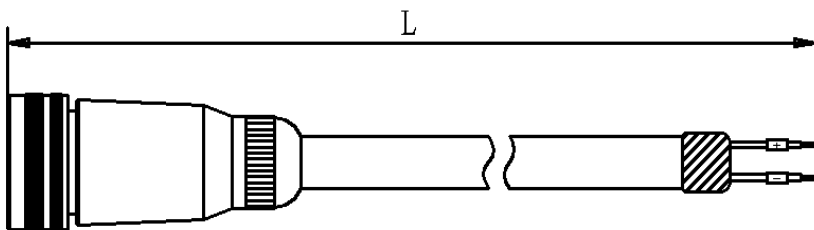

Holding brake line model: VB*-D*

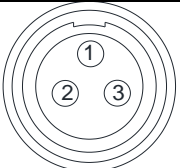
	VM5 series 180 flange (D2) with holding brake motor's holding brake line definition		
	Signal definition	Pin number	Wire core color
	BAKE+	1	Orange
	BAKE-	2	Grey

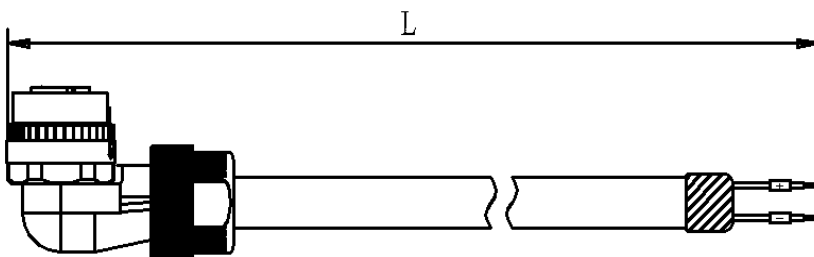

Holding brake line model: VB*-C*

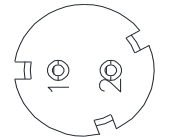
	180 flange (E2M) with holding brake motor's holding brake line definition		
	Signal definition	Pin number	Wire core color
	BAKE+	1	Orange
	BAKE-	2	Grey



110 flange, 130 flange and VM7 series 180 flange with brake motors have the holding brake line and the power line together (9 pins), so you only need to select the matching power line when selecting the motor.

3.5 CN7 USD Communication Terminal (Connect to Host Machine)

Note: ordinary Android cable with data transmission function can also be used

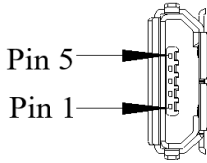

Pin No.	Name	Function
1	VBUS	External power supply + 5V
2	D-	Data-
3	D+	Data+
4	-	None
5	GND	Signal ground

3.6 Connection of CN6A and CN6B Communication Terminal

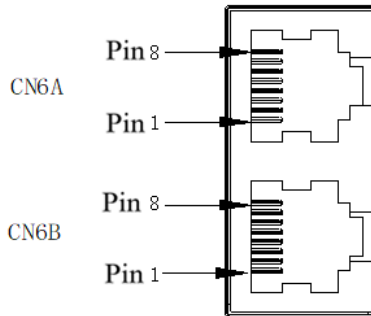

According to different models, the definition of the port is different. When using it, you need to confirm the model before defining the interface. For model identification, please refer to “1.6 driver naming”. The field identification bit E is P: pulse type; S: standard type; C: CANopen bus type; N: PROFINET bus type.

CN6A/CN6B port definition					
Pin No.	Signal name	Function	Pin No.	Signal name	Function
1	CANH	CAN Data+	6	-	
2	CANL	CAN Data -	7	GND	485 Signal ground
3	CANG	CAN Signal ground	8	-	-
4	485-	485 Data -	Shell	Shield	Shield

5	485+	485 Data +			

The field identification bit E is M:MECHATROLINK-II bus type.

CN6A/CN6B port definition					
Pin No.	Signal name	Function	Pin No.	Signal name	Function
1	SRD+	M-II Data +	6	-	-
2	SRD-	M-II Data -	7	-	-
3	-	-	8	-	-
4	-	-	Shell	Shield	Shield
5	-	-			

The field identification bit E is E:EtherCAT bus type;L: MECHATROLINK-III bus type; N: PROFINET bus type.

CN6A/CN6B port definition					
Pin No.	Signal name	Function	Pin No.	Signal name	Function
1	TX+	Data transmission+	6	RX-	Data reception -
2	TX-	Data transmission-	7	-	-
3	RX+	Data reception +	8	-	-
4	-	-	Shell	Shield	Shield
5	-	-			

As for using multiple drivers at the same time, the cascade mode is CN6A in and CN6B out. Failure to follow the cascade mode of up in and down out may lead to abnormal communication. Please try to ensure that the length of the cascaded cable is less than 50cm, and the CN6B of the last one should be connected with the terminal resistance (Only CANopen bus/ Mechatrolink-II bus/ RS-485 bus should be considered with terminal resistance).

3.7 CN5 Full Closed Loop Port

2500 line encoder and full closed loop port (differential input)					
Pin No.	Signal name	Function	Pin No.	Signal name	Function
1	EA-	Full closed loop signal EA-	9	-	-
2	EB-	Full closed loop signal EB-	10	-	-

3	EZ-	Full closed loop signal EZ-	11	-	-
4	-	-	12	-	-
5	-	-	13	0V	Encoder power supply 0V
6	EA+	Full closed loop signal EA+	14		
7	EB+	Full closed loop signal EB+	15	5V	Encoder power supply 5V
8	EZ+	Full closed loop signal EZ+	Shell	Shield	-

3.8 CN1 Multifunctional Control Terminal Definition

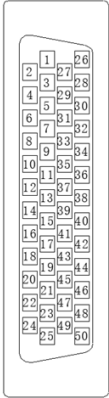

2	GND	Ground	1	GND	Ground	27	/SO2+ (COIN+)	General sequence control output 2	26	/SO1- (S-RDY-)	General sequence control output 1
4	-	Reserved	3	PL1	OC power output of command pulse	29	/SO3+ (V-CMP+)	General sequence control output 3	28	/SO2- (COIN-)	General sequence control output 2
6	SG	Signal ground	5	V- REF	Speed command input	31	ALM+	Servo alarm output	30	/SO3- (V-CMP-)	General sequence control output 3
8	/PULS	Pulse command input	7	PULS	Pulse command input	33	PAO	A phase of encoder pulse division output	32	ALM-	Servo alarm output
10	GND	Ground	9	T- REF	Torque command input	35	PBO	B phase of encoder pulse division output	34	/PAO	A phase of encoder pulse division output
12	/SIGN	Sign command input	11	SIGN	Sign command input	37	-	Reserved	36	/PBO	B phase of encoder pulse division output
14	/CLR	Clearance input of position deviation	13	PL2	OC power output of command pulse	39	/SI7	General sequence control input 7	38	/SI8	General sequence control input 8
16	OC	OC power input of command pulse	15	CLR	Clearance input of position deviation	41	/SI3 (P-CON)	General sequence control input 3	40	/SI0 (/S-ON)	General sequence control input 0
18	PL3	OC power output of command pulse	17	OCS	OC input of pulse direction	43	/SI2 (N-OT)	General sequence control input 2	42	/SI1 (P-OT)	General sequence control input 1
20	/PCO	C phase of encoder pulse division output	19	PCO	C phase of encoder pulse division output	45	/SI5 (/TCL)	General sequence control input 5	44	/SI4 (/ALM-RTS)	General sequence control input 4
22	BAT-	Battery(-) of absolute encoder	21	BAT+	Battery (+) of absolute encoder	47	+24VIN	Power input of sequence control input signal	46	/SI6	General sequence control input 6
24	OCS	OC input of pulse clearance	23	OCZ	OC output of Z phase pulse division	49	-	Reserved	48	-	Reserved
			25	/SO1+ (S-RDY+)	General sequence control output 1				50	TH	Overheat protection input of linear motor

! Cautions

When tightening the screw of CN1 terminal, the torque should not be greater than 0.2N. M, otherwise, the screw may slip.

3.9 Digital Input Signal

3.9.1 Input Signal Descriptions

Control mode	Signal name	Pin No.	Function number and Description		
Common	/S-ON	Allocated signal (38 ~ 46)	0x01	Signal to control servo motor ON/OFF (power on/power off)	
	POT		0x02	Positive limit to stop the servo motor drive when the mechanical movement exceeds the movable range (overtravel prevention function)	
	NOT		0x03	Negative limit to stop the servo motor drive when the mechanical movement exceeds the movable range (overtravel prevention function)	
	/ALM-RST		0x04	Alarm Reset	
	/P-CON		0x05	P action command, when the signal is ON, the speed control loop switches from PI (proportional, integral) control to P (proportional) control	
	/TLC		0x06	Torque limit switching, used when the torque limit needs to be changed during operation	
	/SPD-D		0x08	Used to change the direction of motor control at internal speed	
	/SPD-A		0x09	When running in internal speed mode, it is used to select the internal speed command of the segment	
	/SPD-B		0x0A		
	/C-SEL		0x0B	Control mode switching, when the control mode is mixed mode, used to switch the control mode	
	/ZCLAMP		0x0C	Zero fixed signal, used as zero fixed in speed mode	
	/INHIBIT		0x0D	Pulse input prohibition, used as disable pulse input count in position mode	
	/G-SEL		0x0E	Gain selection, when the gain is switched manually, it is used to switch the gain	
	/PSEL		0x10	Command pulse input rate switching, used to switch pulse input rate signal in position mode	
		+24VIN	47	Used when the control signal is input by control power Operating voltage range: +11V ~ +25V (+24V power supply should be provided by users.)	
		SEN	4	Input signal requiring initial data when using an absolute encoder	
	BAT+ BAT-	21 22	Spare battery connection pin for absolute encoder (Note) Do not connect the encoder cable with the battery unit when using		
Speed	V-REF	5 (6)	Input speed command. Max. input voltage: $\pm 10V$		
Position	PULS	7	Set any of the following input pulse patterns Symbol + pulse sequence CW+CCW pulse sequence 90° phase difference 2-phase pulse		
	/PULS	8			
	SIGN	11			
	/SIGN	12			
	CLR /CLR	15 14	Clear position deviation during position control		
Torque	T-REF	9 (10)	Input torque command, input voltage range: $\pm 10V$		

3.9.2 Input Signal Configuration

1. The digital input signal distribution mode is internally fixed (Pn600=0). The function servo unit of each input signal is internally fixed and cannot be changed. When selecting different control modes, the functions of the pins are different as shown in the following table:

Control mode (Pn000)	NO. of CN1 pins							
	40	42	43	41	44	45	46	38/39
0- Position control	/S-ON servo enable	P-OT forward limit	N-OT reverse limit	/P-CON proportional control	/ALM-RST alarm clear	/TLC torque limit switching	Reserved	Invalid
1- Analog speed								
2- Torque control								
3- Internal speed				/SPD-D internal speed command direction selection		/SPD-A internal speed command selection A	/SPD-B internal speed command selection B	
4- Internal speed <-> analog speed								
5- Internal speed <-> position								
6- Internal speed <-> torque								
7- Position <-> analog speed				/C-SEL control mode switching		Reserved		
8- Position <-> torque								
9- Torque <-> analog speed								
10- Speed <-> speed control with zero fixed function							/ZCLAMP zero Position fixed	
11- Speed <-> position control with command pulse inhibit function	/INHIBIT command pulse prohibition							

2. The switching input signal distribution mode is the parameter configuration (Pn600=1 default parameter). The function of each input signal is configured by the user and is set by parameters Pn601 ~ Pn609.

a) Default setting

Function code	NO. of CN1 pins	Default function
Pn601	40	0x01: Servo enable
Pn602	42	0x02: Forward prohibition
Pn603	43	0x03: Reverse prohibition
Pn604	41	0x05: Manual PI-P control
Pn605	44	0x04: Alarm reset
Pn606	45	0x06: Torque limit switching
Pn607	46	0x07: Reserved
Pn608	39	0x00: Invalid
Pn609	38	

b) Reverse

The drive provides reverse input signal switching function in order to facilitate wiring:

1. Take the servo enable (/S-ON) as an example, the default setting is Pn601=0x01. When the signal is ON, the servo is enabled. When the setting is Pn601=0x101, the servo is disabled when the signal is ON.
2. Take the forward limit (POT) as an example, the default setting is Pn602=0x02. When the signal is OFF, the servo forward limit is set. If the setting is Pn602=0x102, the servo forward stroke limit is released when the signal is OFF.



Cautions

1. Signal ON: The state when the switch input signal (/S - ON, etc.) is connected to the "ground terminal" of the external +24VIN power supply.
2. Signal OFF: The state when the switch input signal (/S - ON, etc.) is disconnected from the "ground terminal" of the external +24VIN power supply.
3. The positive travel limit (POT)/negative travel limit (NOT) of the switch input signal is a valid signal for OFF, and the other input signals are valid signals for ON, so pay attention to the distinction in use.

c) Always Valid

Through the setting of parameters Pn610, Pn611 and Pn612, the configured input signal can always be valid. For example, when Pn610=0x01 (servo enable), the servo is always in the enabled ON state after power-on, and the external enable signal (/S-ON) does not take effect.



Cautions

If the same function is configured on different pin numbers, Er.040 (parameter setting abnormality alarm) will be reported, and the related alarm and handling methods are detailed in "Fault Code and Countermeasures".

3.9.3 Confirming the Input Status

The status of the input signal can be checked by input signal monitoring (Un100). The Un100 segment display and corresponding Pin No.s are as follows:

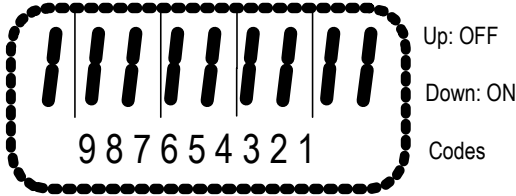

Display LED	Pin No	Signal Name
1	CN1-40	/S-ON
2	CN1-41	/P-CON
3	CN1-42	P-OT
4	CN1-43	N-OT
5	CN1-44	/ALM-RST
6	CN1-45	/TLC
7	CN1-46	Reserved
8	CN1-39	Invalid
9	CN1-38	Invalid

The upper SEG (LED) lights up when the input signal is OFF.

The lower SEG (LED) lights up when the input signal is ON.

The value (address: 0XE100) read over the communication is hexadecimal, for example, the read value is 0x1FE. Under the default input configuration, it means that the input of /S-ON (CN1-40) is ON, that is, servo enable, and the input of other input pins is OFF.

3.10 Digital Output Signal

3.10.1 Output Signal Descriptions

Control Mode	Signal Name	Pin No.	Descriptions	
Common	/TGON	Allocated signals 25(+) 26(-) 27(+) 28(-) 29(+) 30(-)	0x03	ON (closed) when the speed of the servo motor is higher than the set value.
	/S-RDY		0x00	ON (closed) when servo ON (/S-ON) signal is acceptable.
	/CLT		0x04	Torque limit ON (closed) when the motor output torque is limited.

	/VLT		0x05	In the speed limit, the motor speed is ON after closing the speed limit (closed).
	/BK		0x06	Brake interlocking, the output of the motor is ON during operation. Refer to "Retaining the brake" for timing details.
	/WARN		0x07	Warning output.
Speed	/V-CMP		0x02	Consistent speed output ON when the speed of the servo motor is the same as the command speed (closed).
Position	/COIN		0x01	Positioning completed output ON (closed) when the difference between the command pulse number and the servomotor movement amount (position deviation) is lower than the position reach range.
	/PSELA		0x09	Command pulse override switching can be switched to operate with the value of the input command pulse n times (Pn203).
	/NEAR		0x08	Positioning close, output ON (closed) when the difference between the positioning command pulse number and the servo motor movement amount (position deviation) is lower than the position proximity signal.
	PL1 PL2 PL3	3 13 18	Position pulse is power supply for open collector command.	
Common	ALM+ ALM-	31(+) 32(-)	OFF (disconnected) at alarm (Output logic can be changed by parameter).	
	PAO /PAO	33 34	Frequency division output A phase signal.	
	PBO /PBO	35 36	Frequency division output B phase signal.	
	PCO /PCO	19 20	Frequency division output C phase signal.	

3.10.2 Output Signal Configuration

a) Default

The function of each output signal is configured by the user and is set by parameters Pn613 ~ Pn615. The default functions are as follows:

Function code	CN1 Pin No.	Default function
Pn613	25/26	0x00: Servo ready
Pn614	27/28	0x01: Positioning completed
Pn615	29/30	0x02: Consistent speed

b) Negation

1. Common switch output signal inversion function, take the servo ready signal (/S-RDY) as an example, default setting Pn613=0x00, servo ready and then the output signal is ON; change the setting Pn613=0x100, the servo is ready, then the output signal is OFF.
2. The alarm output signal (ALM) is the output of the fixed Pin No. The default setting is Pn622.1=0. If the servo alarm occurs, the output signal will be OFF. If the change is set to Pn622.1=1, the servo alarm will output the signal ON.

!

Cautions

1. Pn622.1 indicates the first bit of parameter Pn622, see the explanation of function code parameter.
2. No output signal is "invalid" state. Eg: Speed control, positioning completion (/COIN) signal is "invalid".
3. If the polarity of the brake signal (/BK) is reversed and used with positive logic, the brake will not operate when the signal line is disconnected. When this setting has to be used, be sure to check the operation to ensure that there are no safety problems.
4. When multiple signals are assigned to the same output circuit, they will be output in heterogeneous logic.

3.10.3 Confirming the Output Status

The status of the output signal can be confirmed by the output signal monitor (Un101). The Un101 segment display and corresponding Pin No.s are as follows:

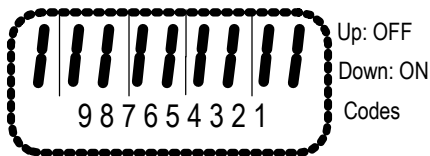

Display LED	Pin No.	Signal Name
1	CN1-31、32	ALM

2	CN1-25、26	/S-RDY
3	CN1-27、28	/COIN
4	CN1-29、30	/V-CMP

The upper SEG (LED) lights up when the output signal is OFF.

The lower SEG (LED) lights up when the output signal is ON.

The value read through communication is hexadecimal, for example: the read value is 0X8, and the default output configuration means that ALM (CN1-31, 32) output is ON, that is, no alarm output. /S-RDY (CN1-25, 26) output is OFF, that is servo ready. /COIN (CN1-27, 28) output is OFF, that is positioning is completed. /V-CMP (CN1-29 / 30) output is ON, and the speed is not consistent.

3.11 Connection with the Upper Device

3.11.1 Analog Input Circuit

The following describes the 5-6 (speed command input) and 9-10 (torque command input) terminals of the CN1 connector.

Analog signals are speed commands or torque command signals. The input impedance is as follows.

Speed command input: about 66k Ω .

Torque command input: about 66k Ω .

The maximum allowable input signal voltage is $\pm 10V$.

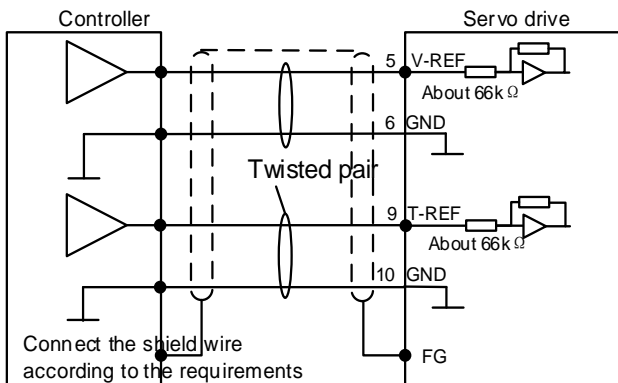

The above wiring is an example of wiring during forward rotation.

3.11.2 Position Instruction Input Circuit

The following describes the 7-8 (command pulse input), 11-12 (command symbol input), and 14-15 (clear input) terminals of the CN1 connector. The output circuit of the command pulse and position deviation clear signal from the host device may be one of the linear driver output and the open

collector output.

Connection example of linear drive output

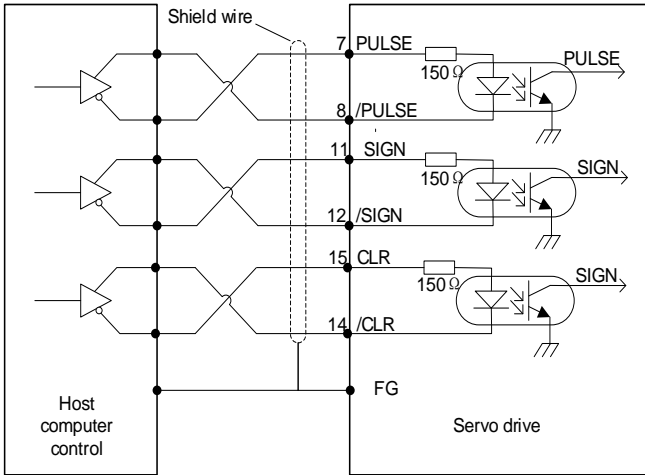

The differential pulse input signal voltage is $\pm 3.3V$ and the maximum frequency is 4MHz. This signal transmission method has the best anti-noise capability. It is recommended to use this connection preferentially.

Connection example of open collector output

External 24V power supply:

1. Control module is NPN type (common cathode):

Internal 15V power supply:

1 Control module is NPN type (common cathode):

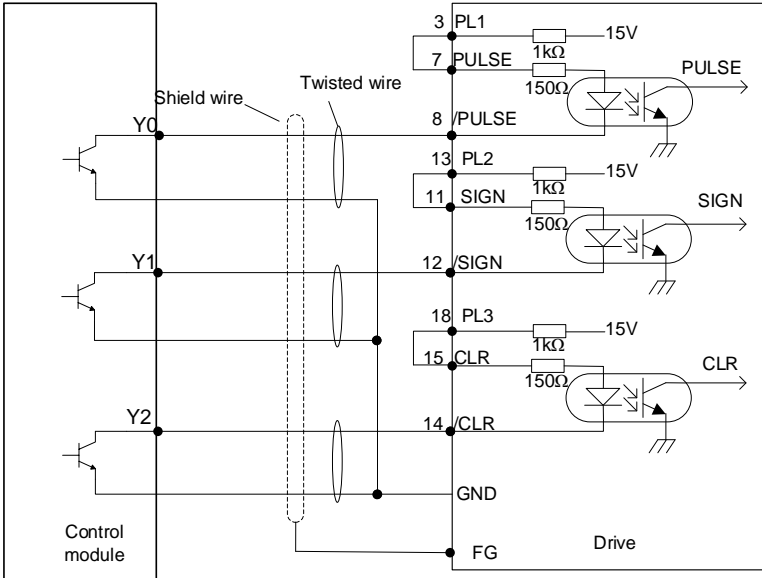

2 Control modules is PNP type (common anode):

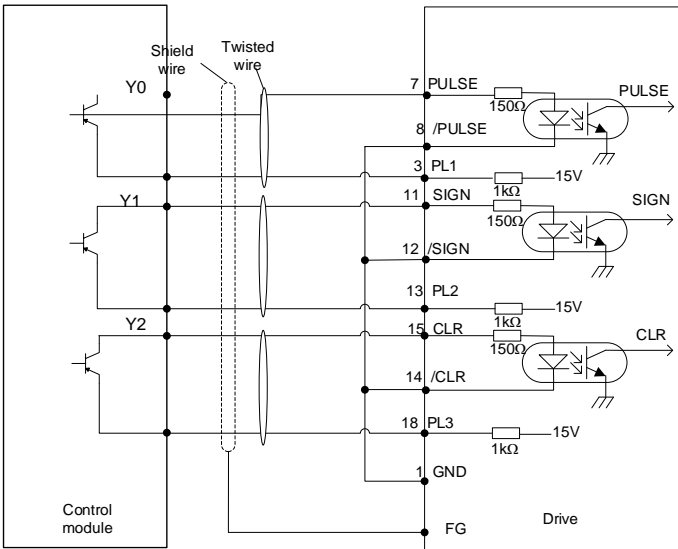

3.11.3 Sequence Control Input Circuit

The following describes the 38 to 46 terminals of the CN1 port. Connect via a relay or open collector transistor circuit. When using a relay connection, select the relay for the minute current. If you do not use a minute current relay, it will cause poor contact.

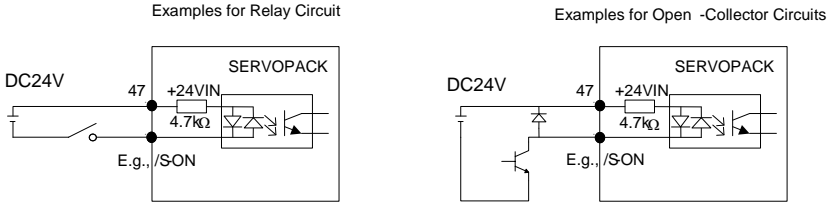

Note: The external power supply (DC24V) must have a capacity of 50 mA or more. The input loop of the servo unit uses a bidirectional optocoupler. Please select the sink circuit connection or the source circuit connection according to the specifications of the machine.

3.11.4 Sequence Output Loop

Servo unit signal output circuit is the following three kinds:

1. Open collector output circuit

The output signal (SEN, OCZ) is an open collector transistor output circuit. Please receive through optocoupler circuit, relay circuit or linear receiver circuit.

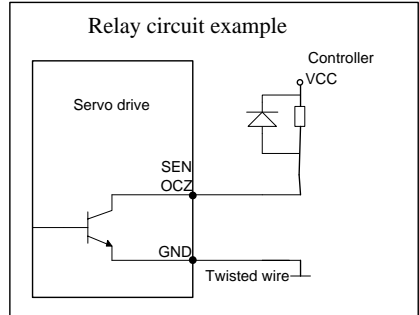
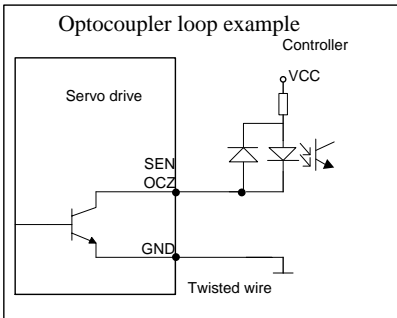

2. Optocoupler output circuit

The brake linkage (/BK), servo alarm (ALM), servo ready (/S-RDY) and other sequence output signals belong to the optocoupler output circuit. Connect via relay or line receiver circuit.

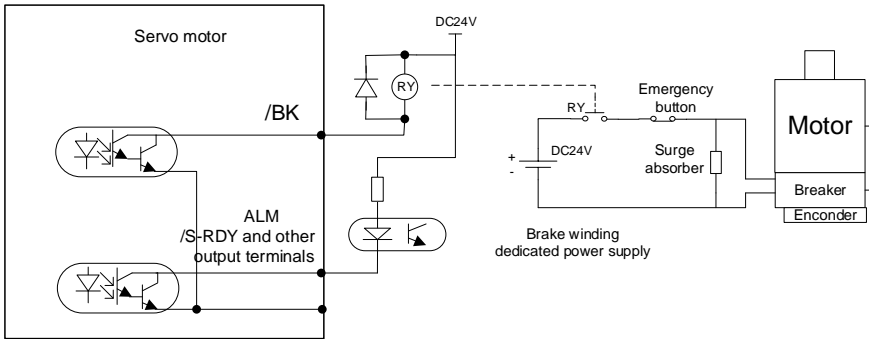

3. Linear drive output circuit

The following describes the 33-34 (phase A signal), 35-36 (phase B signal), and 19-20 (phase C signal) terminals of the CN1 port. The output signal (PAO, /PAO, PBO, /PBO) and the origin pulse signal (PCO, /PCO) of the encoder's serial data are converted into two-phase (A-phase, B-phase) pulses and output through the line driver output circuit. On the upper device side, please use a linear receiver circuit.

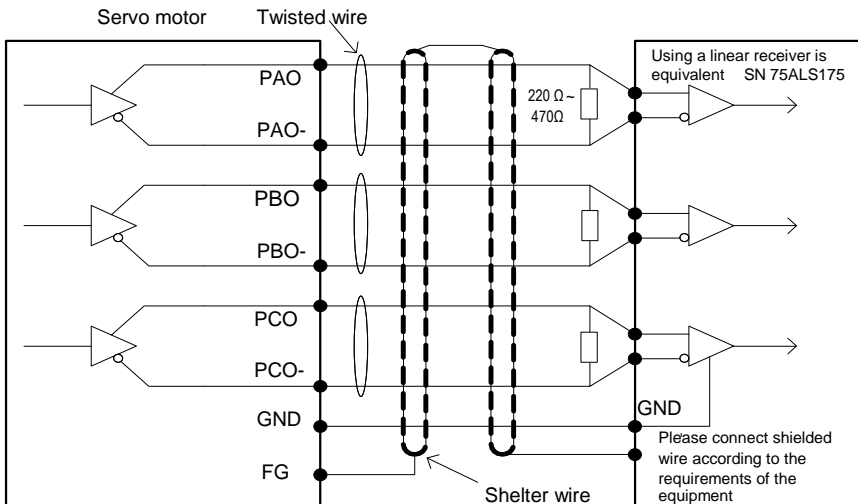

3.12 Position Control Wiring Diagram

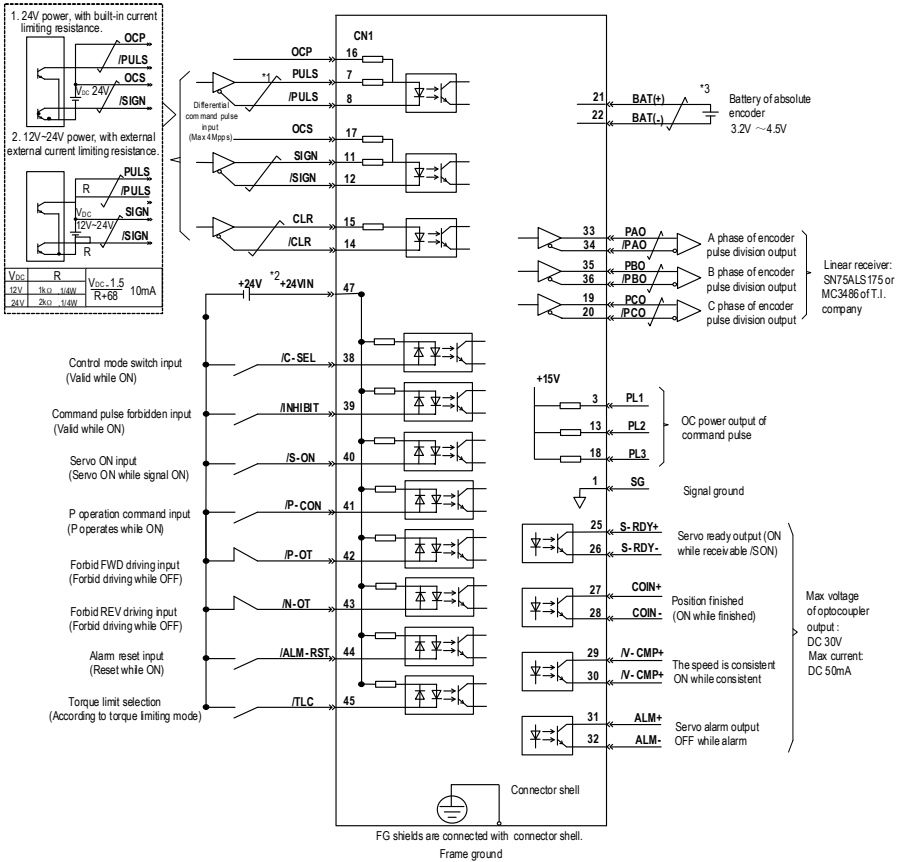

*1. ∇ is twisted shields.

*2. DC24V power should be prepared by user. And double insulation or reinforced insulation equipment should be used for DC24V power.

*3. Connected while using absolute encoder. But never connect backup battery while using encoder cables with battery unit.

*4. Output signal should be received by linear receiver.

Note: while using 24V breaker, DC24V power should be separated from the power for input and output signal (CN1). Please prepare other power individually, otherwise, there may be misoperation of input and output signal while power on.



If the input voltage of the linear drive input port is greater than 12V, please connect the appropriate current limiting resistor in series in the circuit, otherwise, the linear drive input port may be damaged.

3.13 Speed Control Wiring Diagram

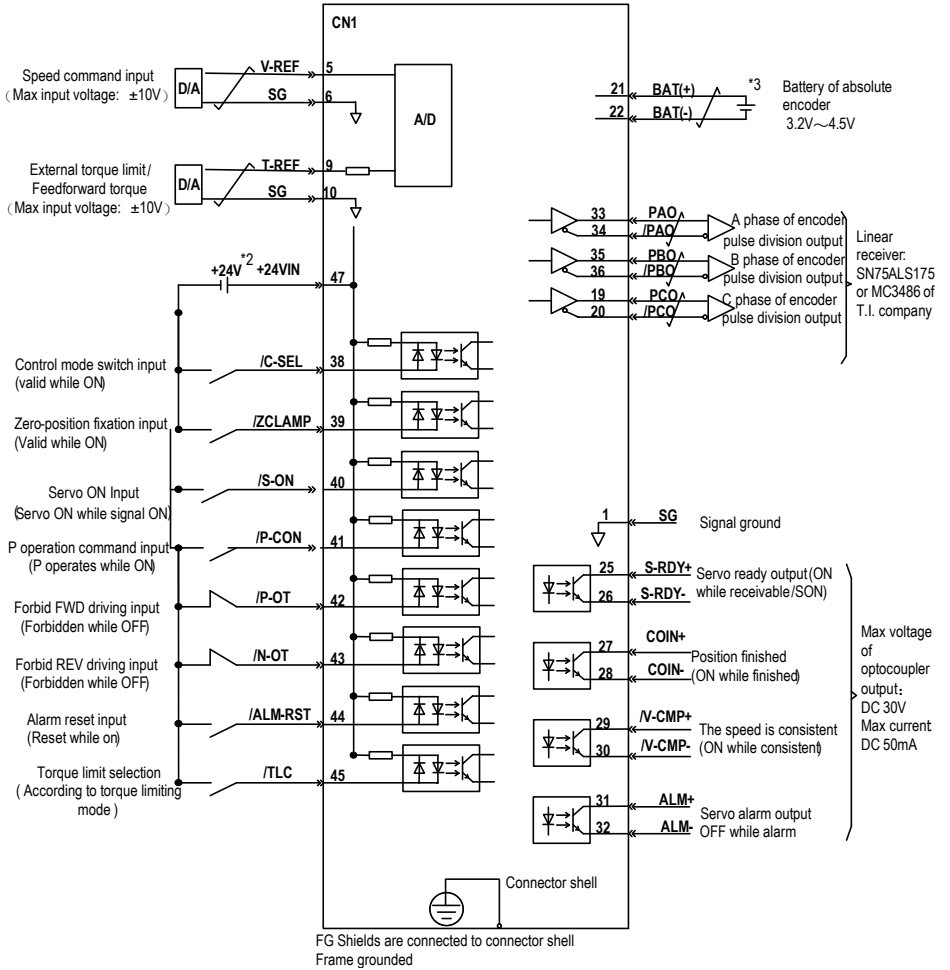

3.14 Torque Control Wiring Diagram

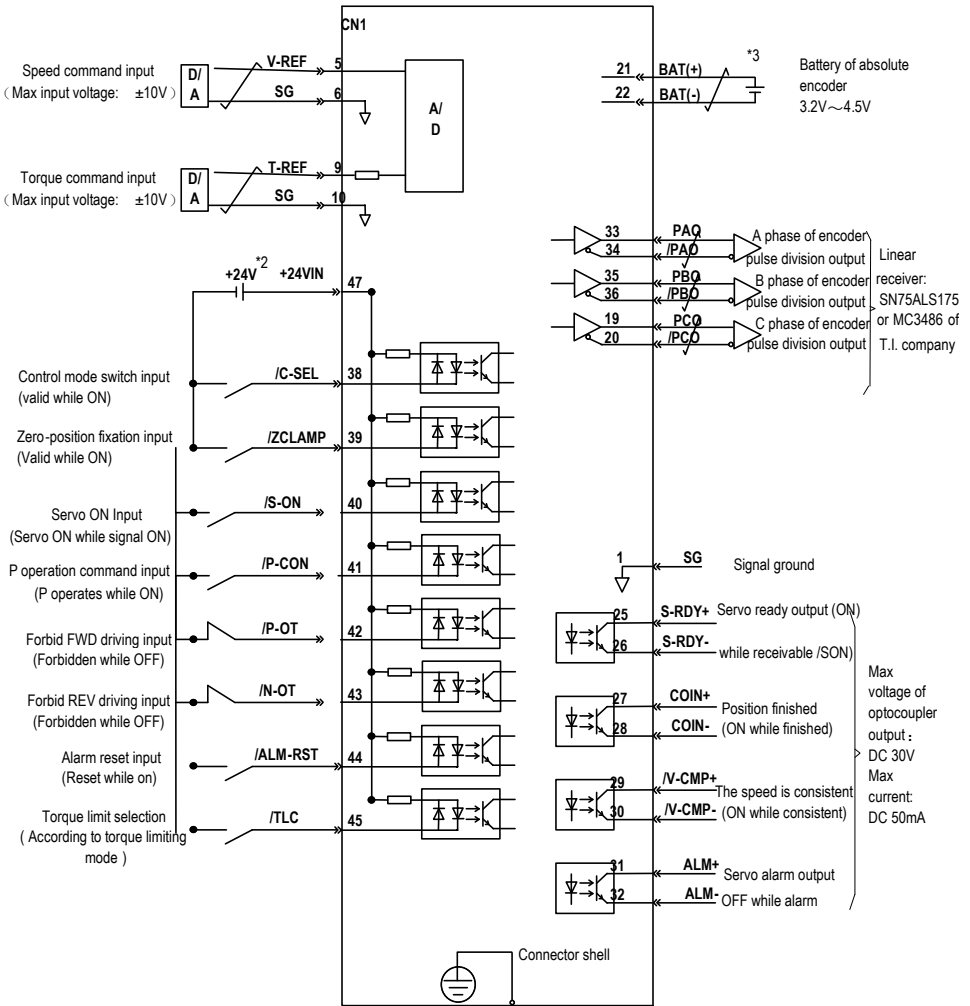

FG Shields are connected to connector shell
Frame grounded

*1. is the twisted shields.

*2. DC24V power should be prepared by user. And double insulation or reinforced insulation equipments should be used for DC24V power.

*3. Connected while using absolute encoder. But never connect backup battery while using encoder cables with battery unit.

*4. Output signal should be received by linear receiver.

Note: While using 24V braker, DC24V power should be separated from the power for input and output signal (CN1). Please prepare other power individually, otherwise, there may be misoperation of input and output signal while power on.

3.15 Regenerative Resistor Connection

When the regenerative energy processing capacity is insufficient, connect an external regenerative resistor as required to set the regenerative resistor capacity (Pn012) and the regenerative resistor value (Pn013).

3.15.1 Connection of Regenerative Resistors

The driver models 1R1A,1R7A,3R3A,500D,600D have no built-in regenerative resistor. When a regenerative resistor is externally connected, the resistor is connected to the B1/+ and B2 terminals. Refer to "A single-phase wiring diagram". Or it is connected to the + and PB terminals. Refer to "E/F single-phase wiring diagram".

In addition to 1R1A, 1R7A,3R3A,500D,600D the driver model has a built-in regenerative resistor. When the internal regenerative resistor does not meet the requirements, a regenerative resistor can be connected to remove the short wiring between the B2-B3 terminals and connect the external regenerative resistor to the driver. For B1/+, B2 terminals, refer to "B/C/D/E/F volume three-phase wiring diagram".

3.15.2 Selection of Regenerative Resistor

Mode	Braking Voltage(V)	Internal resistor	Min. value of external resistor(Ω)	Max. value of external resistor(Ω)
SD700-1R1A	380	/	40	400
SD700-1R7A		/	40	200
SD700-3R3A		/	40	100
SD700-5R5A		40 Ω 60W	25	70
SD700-7R6A		40 Ω 60W	15	50
SD700-9R5A		40 Ω 60W	15	40
SD700-120A		30 Ω 200W	10	30
SD700-160A		30 Ω 200W	10	30
SD700-2R5D	700	80 Ω 60W	80	225
SD700-3R8D		80 Ω 60W	55	180
SD700-6R0D		40 Ω 60W	35	110
SD700-8R4D		40 Ω 60W	25	85
SD700-110D		40 Ω 60W	25	70
SD700-170D		30 Ω 100W	30	50
SD700-240D		30 Ω 200W	15	40

SD700-300D		30Ω 200W	15	30
SD700-500D		/	10	20
SD700-600D		/	10	20

Note: When external braking resistor is needed, please select the resistance value of the braking resistor according to the above table. Select the braking resistor's power according to the braking frequency of the field conditions and the cooling conditions of the braking resistor, you could consult factory if you have any problem.

3.16 Fuse

To prevent accidents due to short circuits, be sure to connect a fuse or circuit breaker on the input side.

Servo drive		Recommended fuse		
Drive model	Rated input current(A)	Manufacturer	Rated current (A)	Model No.
Single-phase 200-240V				
SD700-1R1A	1.28	SinoFuse	15	RS309-MF
SD700-1R8A	2.1	SinoFuse	15	RS309-MF
SD700-3R3A	3.89	SinoFuse	20	RS309-MF
Three-phase 200-240V				
SD700-5R5A	3.1	SinoFuse	20	RS309-MF
SD700-7R6A	4.2	SinoFuse	25	RS309-MF
SD700-9R5A	5.2	SinoFuse	30	RS309-MF
SD700-120A	10.3	SinoFuse	35	RS309-MF
SD700-160A	13.7	SinoFuse	40	RS309-MF
Three-phase 380-440V				
SD700-2R5D	2.8	SinoFuse	15	RS309-MF
SD700-3R8D	4.18	SinoFuse	15	RS309-MF
SD700-6R0D	8.8	SinoFuse	20	RS309-MF
SD700-8R4D	12.4	SinoFuse	20	RS309-MF
SD700-110D	16.2	SinoFuse	35	RS309-MF
SD700-170D	22.4	SinoFuse	50	RS309-MF
SD700-240D	31.6	SinoFuse	70	RS309-MF
SD700-300D	39.5	SinoFuse	90	RS309-MF
SD700-500D	46.7	SinoFuse	125	RS309-MF
SD700-600D	56	SinoFuse	125	RS309-MF

Note: There is no restriction on the fuse manufacturer, and the fuse protection characteristics can be consistent with the recommended fuses in the above table.

3.17 Circuit Breaker

Servo drive		Recommended circuit breaker		
Drive model	Input current (A)	Manufacturer	Rated current (A)	Model No.
Single-phase 230V				
SD700-1R8A	2.2	Schneider Electric	6	OSMC32N2C6
SD700-3R3A	4.6	Schneider Electric	6	OSMC32N2C6
Three-phase 230V				
SD700-5R5A	4.6	Schneider Electric	6	OSMC32N3C6
SD700-7R6A	5.7	Schneider Electric	16	OSMC32N3C16
SD700-9R5A	6.9	Schneider Electric	16	OSMC32N3C16
SD700-120A	8	Schneider Electric	16	OSMC32N3C16
SD700-160A	9	Schneider Electric	20	OSMC32N3C20
Three-phase 400V				
SD700-2R5D	1.6	Schneider Electric	4	OSMC32N3C4
SD700-3R8D	2.5	Schneider Electric	6	OSMC32N3C6
SD700-6R0D	3.8	Schneider Electric	6	OSMC32N3C6
SD700-8R4D	5.6	Schneider Electric	16	OSMC32N3C16
SD700-110D	8	Schneider Electric	16	OSMC32N3C16
SD700-170D	12.4	Schneider Electric	16	OSMC32N3C20
SD700-240D	18.2	Schneider Electric	25	OSMC32N3C25
SD700-300D	23	Schneider Electric	32	OSMC32N3C32
SD700-500D	125	Schneider Electric	50	OSMC32N3C50
SD700-600D	125	Schneider Electric	63	OSMC32N3C63

If residual current operated protective device (RCD) is to be used for the equipment, please select the type according to the following conditions:

- The drive equipment can generate DC leakage current in the protective conductor. Please be sure to use type B residual current operated protective device (RCD).
- When the drive is running, it will generate certain high-frequency leakage current. In order to avoid RCD misoperation, please select RCD with an operating current of not less than 100mA for each drive.
- When multiple drives are connected in parallel to share one RCD, select an RCD with an action current of not less than 300mA.
- We recommend to use RCD of Chint (正泰), Schneider (施耐德) or other brands.

3.18 EMC Filter

Selection of models

In order to make this product meet the radiation and conductive emission requirements of EN IEC 61800-3 standard, the EMC filter listed in the following table needs to be connected externally. The EMC filters available for customers are the FN2090 and FN3258 series of Schaffner Company. Please select from the following table according to the rated input current of the product:

Servo drive			Recommended filter	
SIZE	Drive model	Input current (A)	Manufacturer	Model No.
Single-phase 230V				
SD700-1R8A	SD700-1R8A	2.2		
SD700-3R3A	SD700-3R3A	4.6	Schaffner	FN2090-4-06
Three-phase 230V				
SD700-5R5A	SD700-5R5A	4.6		
SD700-7R6A	SD700-7R6A	5.7		
SD700-9R5A	SD700-9R5A	6.9	Schaffner	FN2090-10-06
SD700-120A	SD700-120A	8		
SD700-160A	SD700-160A	9	Schaffner	FN2090-16-06
Three-phase 400V				
SD700-2R5D	SD700-2R5D	1.6		
SD700-3R8D	SD700-3R8D	2.5	Schaffner	FN3258-7-44 FN3258-16-44
SD700-6R0D	SD700-6R0D	3.8		
SD700-8R4D	SD700-8R4D	5.6		
SD700-110D	SD700-110D	8	Schaffner	FN3258-16-44
SD700-170D	SD700-170D	12.4		
SD700-240D	SD700-240D	18.2		
SD700-300D	SD700-300D	23	Schaffner	FN3258-30-33
SD700-500D	SD700-500D	125		
SD700-600D	SD700-600D	125	Schaffner	FN3258-75-34

3.19 Noise and High Harmonic Countermeasures

The following describes noise and harmonic measures:

This servo unit has a built-in microprocessor. Therefore, it may be subject to noise from its peripheral equipment.

To prevent mutual noise interference between the servo unit and its peripheral devices, the following

measures to prevent noise interference can be taken as required.

- Set the input command device and noise filter as close to the servo unit as possible.
- Be sure to connect a surge suppressor to the coils of relays, solenoids, and electromagnetic contactors.
- Do not use the same bushing for the main circuit cable and the input/output signal cable/encoder cable, and do not bind them together. When wired, the main circuit cable and the input/output signal cable/encoder cable should be separated by more than 30cm.
- Do not use the same power supply as the electric welder or EDM machine. Even if it is not the same power supply, connect a noise filter to the input side of the main circuit power cable and the control power cable when there is a high-frequency generator nearby.

4 Trial Operation

4.1 Inspections and Notes before Trail Operation

In order to ensure the safe and correct trail operation, please check the programs as below before that:

4.1.1 Conditions of the Servo Motor

You need to check and confirm all programs as below, if there is any problem, please handle it properly before that trail operation

- Are the settings, wires and connections correct?
- Is there any looseness in each fastening part?
- When you use servo motors with oil seals, is the oil seal damaged? Is it smeared with organic oil?
- Is the brake released beforehand when it is a servo motor with a holding brake?

4.1.2 Conditions of the Servo Drive

You need to check and confirm all programs as below, if there is any problem, please handle it properly before that trail operation.

- Are the settings, wires and connections correct?
- Is the supply voltage of the servo unit normal?
- Is the driver status display interface free of warnings and alarms?

4.1.3 Installation

- Install the servo motor and servo unit according to the installation conditions.
- The servo motor may fall when it rotates, so be sure to fix it on the machine.
- Be sure to leave the servo motor at no load.

4.2 JOG Trail Operation

The trial run refers to the JOG operation of the servo motor unit. The purpose of the single trial operation of the servo motor is to confirm whether the servo unit and the servo motor are correctly connected and whether the servo motor is operating normally. Confirm the following points before running:

1. The motor is in the enabled state and the jog operation is invalid during the operation.
2. We suggest that the load inertia is not greater than 30 times of the motor inertia, or it could possibly cause strong mechanical vibration.
3. The Pn500, Pn310, Pn311 parameters set JOG speed, acceleration and deceleration time.

5 Operation

5.1 Basic Functions

5.1.1 Quick Guide

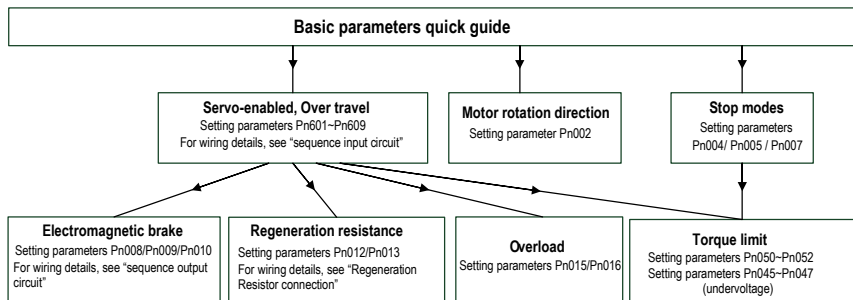

5.1.2 Servo Enable and Over-Travel Setting

Enable

Set the servo ON (/S-ON) signal that controls servo motor electrification / non- electrification. Pin numbers can be configured by parameters Pn601 ~ Pn609, and are always configured effectively by parameters Pn610 ~ Pn612. See "Input Signal Configuration" for details. The internal enable of the servo can also be turned on by setting the parameter PN001 (internal enable switch) to 1.

Over-travel

The over-travel prevention function of the servo unit refers to the safety function of forcibly stopping the servo motor by inputting a signal of the limit switch when the movement part of the machine exceeds the safe movement range. For rotating applications such as disc table and conveyor, the over-travel function may not be required. In this case, the input signal wiring for over-range is not required.



1. In the one way over travel state, commands in the opposite direction of over travel can be received.
2. In position control, when the servo motor stops due to over travel, the position deviation remains unchanged. To clear the position deviation, a clear signal (CLR) must be input.

1. Signal Setting

Pin numbers can be configured by parameters Pn601 ~ Pn609, and are always configured effectively by parameters Pn610 ~ Pn612. See "Input Signal Configuration" for details.

2. Stop Mode

When an over-travel occurs, the servo motor can be stopped by any of the following three methods:

- Dynamic brake (DB) stop: By short-circuiting the electrical circuit, the servo motor can be quickly stopped.
- Deceleration stop: Decelerate to stop with the emergency stop torque (Pn053).
- Coast to a stop: Naturally stopped due to friction when the motor rotates.

The servo motor status after stopping is divided into the following two types:

- Coast mode: A state that naturally stops due to friction when the motor rotates.
- Zero clamp mode: The state of the zero position is maintained in the position loop.
- When the over-travel occurs, select the stopping method of the servo motor through Pn007.

For details, please see parameter Pn007.



It cannot decelerate to stop during torque control. Pn007 is set to DB or free running stop. After the servo motor stops, it enters the free running state.

3. Warning Checkout

The over-travel warning function is a function that detects the over-travel warning (A.9A0) after the over-travel is entered when the servo is turned on. With this function, the servo unit can transmit the information on detecting the over-travel to the host device even if the over-travel signal is input instantaneously. When using this function, please set Pn006=1 “Check over-travel warning”.

The timing of check out over-travel warning:

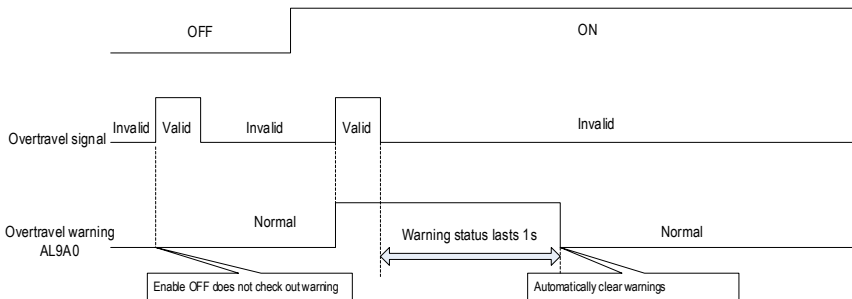

- 1) A warning is detected when an over-travel occurs in the same direction as the instruction.
- 2) Warnings are not detected for over-travel in the reverse direction from the reference. Example: A warning will not be output for a forward instruction even if the N-OT signal (reverse run prohibited).

- 3) When there is no instruction, an over-travel warning in the forward or reverse direction will be detected.
- 4) When the servo is turned OFF, no warning will be detected even if it enters the over-travel status.
- 5) In the over-travel status, no warning is detected when the servo is switched from the servo OFF state to the servo ON status.
- 6) The warning I/O will remain output for 1 second after the over-travel status is released and will be automatically cleared afterwards.

5.1.3 Motor Rotation Direction

The actual rotation direction of the servo motor can be switched by Pn002 without changing the polarity of the speed reference/position reference. At this time, although the rotation direction of the motor is changed, the polarity of the output signal from the servo unit, such as the encoder frequency-divided pulse output, does not change.

Pn002=0 in the factory setting (forward rotation direction) indicates that the counterclockwise rotation (CCW) is positive when looking at the servo motor cover.

Function mode	Parameter	Range	Default	Unit	Communication address	When enabled
Pn002	Motor rotation direction selection	0 ~ 1	0	-	0x0002	After restart
	Faces to the motor end: 0- Counterclockwise direction is positive. 1- Clockwise direction is positive.					

5.1.4 Stop Mode

1. Servo OFF and class 1 alarms

Motor stop method can be selected by Pn004

- Dynamic brake (DB) stops and maintains DB status: By shorting the electrical circuit, the servo motor can be stopped in an emergency, and the DB status is maintained after stopping.
- Dynamic brake (DB) stops and DB status is released: By shorting the electrical circuit, the servo motor can be stopped in an emergency and the DB status is released after stopping.
- Coast to a stop: Stopped naturally, with no control, by using the friction resistance of the servomotor in operation.



When the servo motor stops or rotates at a very low speed, when dynamic braking stop is selected, it will be the same as the free running state. No braking force is generated as in the free running state.

2. Stopping modes for type 2 alarms

Type 2 alarms can select zero speed stop in addition to the servo OFF method and type 1 alarm stop method. See the description of parameter Pn053 for the torque limit at zero speed stop.



The setting of zero speed stop method is only valid for position control and speed control.

5.1.5 Electromagnetic Brake

A holding brake is a brake used to hold the position of the movable part of the machine when the Servo unit is turned OFF so that movable part does not move due to gravity or external forces. Holding brakes are built into servomotors with brakes. Please use it as shown below.

Vertical Axis

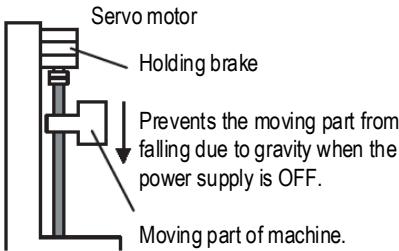

Shaft with External Force Applied

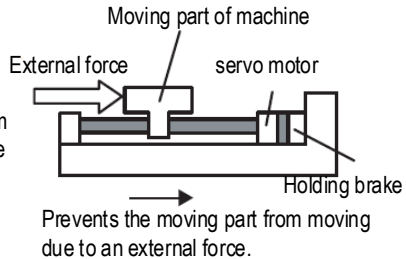

The brake has the following operation delay time. ON and OFF of the operation, please ensure the brake operation time.

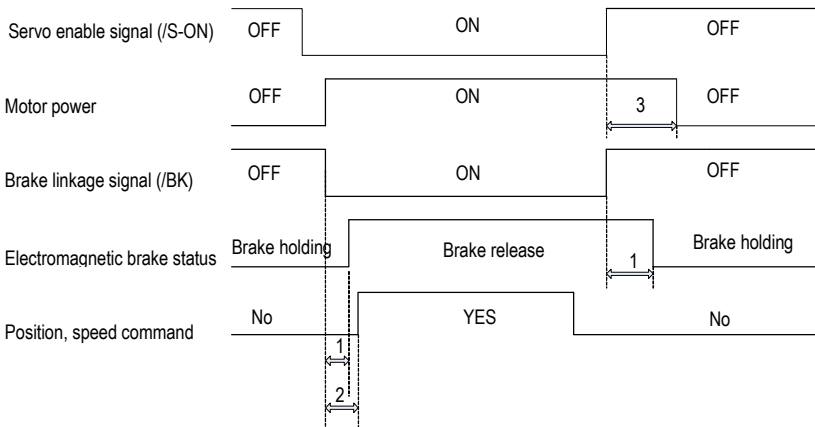

1. Different types of brakes may have slight difference on the time of holding brakes and loosening brakes.

2. Please ensure that the input command is after the brake opening operation to ensure the accuracy of the command.
3. When the motor is locked, it may cause danger when the servo motor is prevented from operating when the servo is turned off. The motor lock time (Pn008) can be set to ensure that the motor during the brake is not operated.

(1) /BK signal OFF timing during the motor running

When an alarm occurs during servo motor rotation, the servo motor stops and the brake signal (/BK) turns OFF. At this time, the brake signal (/BK) output time can be adjusted by setting the brake command output speed value (Pn010) and the servo OFF - brake command waiting time (Pn009), the brake signal (/BK) output time can be adjusted.

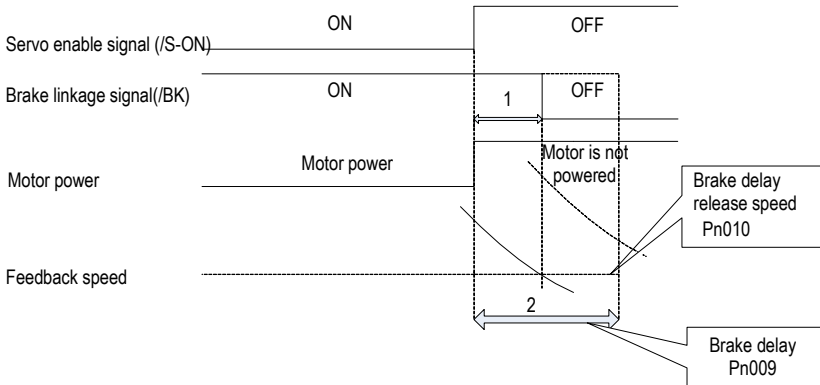

1. When the motor speed is lower than the set value of Pn010 after the power to the servo motor is turned OFF, the /BK signal output time is subject to 1.
2. When the time set in Pn009 is exceeded after the power to the servo motor is turned OFF, and the output time of /BK signal is subject to 2.

(2) /BK signal OFF timing during the motor stopped and locked

When the servo motor is stopped, the brake (/BK) signal and the servo ON (/S-ON) signal are turned off at the same time. By setting Pn008, it is possible to change the time from when the servo ON (/S-ON) signal is OFF to when the motor actually enters the non-energized state.

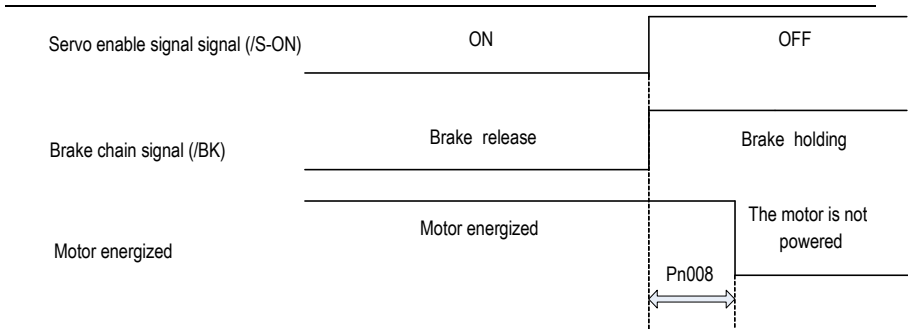



Cautions

An alarm occurs when the servo motor is locked. Regardless of this setting, the servo motor immediately enters the non-energized state..

At this time, the machine may move before the brake due to the delay of the brake action.

5.1.6 Regenerative Resistor

Refer to “Regeneration Resistor Connection” for the wiring method. When connecting an external regenerative resistor, set parameters Pn012 and Pn013 according to the external resistance.

The regenerative resistor capacity should be set to a value that matches the allowable capacity of the connected external regenerative resistor. The setting differs depending on the cooling condition of the external regenerative resistor.

- Self-cooling method (natural convection cooling): Set to 20% or less of the regenerative resistor capacity (W).
- Forced air cooling: Set to 50% or less of the regenerative resistor capacity (W).

Example: When the capacity of the self-cooling external regenerative resistor is 100W, the setting value is $100W \times 20\% = 20W$. Therefore, set Pn012 = 2 (setting unit: 10W).

5.1.7 Overload

This servopack can change the detection time of the overload warning (AL.910) and overload (continuous maximum) alarm (Er. 720). However, it is not possible to change the overload characteristic and the detection value of the overload (instantaneous maximum) alarm (Er. 710). The factory defaults are:

1. Change of the time of detection of overload warning (AL.910)

The factory overload warning detection time is 20% of the overload alarm detection time. The overload warning detection time can be changed by changing the overload warning value (Pn015). In addition, using it as an overload protection function corresponding to the system used can improve the security of the system.

For example, as shown below, after changing the overload warning value (Pn015) from 20% to 50%, the overload warning detection time is half (50%) of the overload alarm detection time.

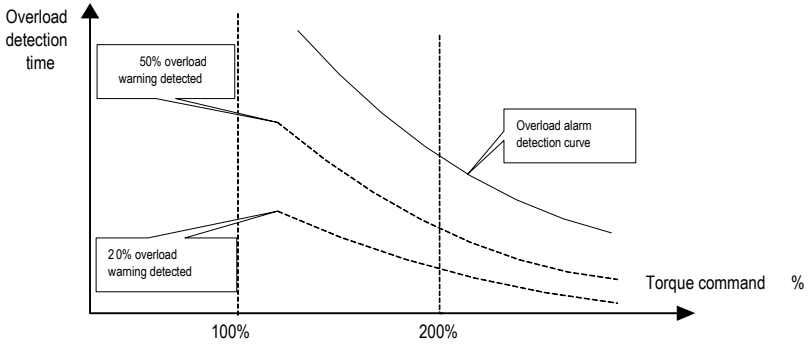

2. Change of the detection time of the overload warning (Er. 720)

The overload (continuous maximum) alarm (Er. 720) can be detected in advance to prevent motor overload.

By detecting the overload alarm by using the “decreased base current”, the overload alarm detection time can be shortened. The detection value of the overload (instantaneous maximum) alarm (Er. 710) cannot be changed.

Motor base current after rating reduction = motor current threshold for calculating overload alarm (default is 1.15 times motor) * motor overload detection base current decrease rated (Pn016).

For example, as shown in the following figure, after setting Pn016 to 50%, the overload alarm can be detected earlier because the motor overload is calculated from 50% of the base current. When the value of Pn016 is changed, the overload alarm detection time will be changed.

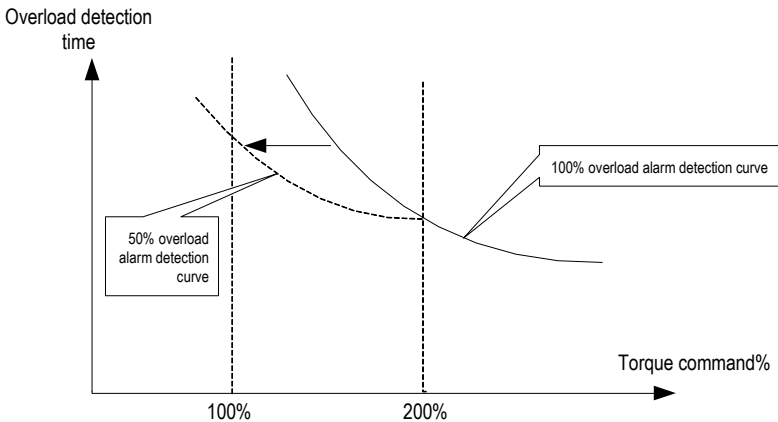

5.1.8 Multi-turn Absolute Encoder

When using a multi-turn absolute encoder, an absolute value detection system can be constructed by a host device. With the absolute value detection system, it is not necessary to perform an origin return operation every time the power is turned on. In order to save the position data of the absolute encoder, a battery unit needs to be installed. Install the battery on the battery unit of the encoder cable with the battery unit. When using an encoder cable without a battery pack, install the battery in the host device. The battery voltage is 3.2V~4.5V. If the battery voltage is lower than 3.2V, a battery under-voltage alarm (ER.830) will appear. Generally, 3.6V/3.7V lithium batteries are used.

Related parameters setting:

Function code	Parameter	Range	Default s	Unit	Communication address	When enabled
Pn040	Method to use absolute encoder	0 ~ 1	0	—	0x0040	After restart
	0- Use an absolute encoder as an absolute encoder: If the motor is an absolute multi-turn encoder, setting this parameter to 0 can use the multi-turn absolute function. This function must be used with the encoder cable with battery, otherwise the servo will alarm (ER.810). 1- Use an absolute encoder as an incremental encoder: When used as an incremental encoder, the power-off position won't be recorded and warning or alarm, corresponding to multiple revolutions, won't happen either when the battery is under-voltage or the drive is de-energized.					
Pn041	Absolute encoder battery warning/warning selection	0 ~ 1	0	—	0x0041	After restart
	0- Set the low battery voltage as a fault: The driver powers up/resets for 4 ~ 9 seconds to monitor the battery status. Under-voltage will be reported as an under voltage alarm (Er. 830). Over time will not be detected. The drive cannot operate normally in a fault status. 1- Set the low battery voltage as a warning: Under-voltage (below 3.2V) will be reported as an under voltage alarm (Al.930). It will always monitor the battery voltage and can be self-recovery meanwhile enable running is out of restriction.					
Pn792	Absolute encoder operation	0 ~ 2	0	—	0x0792	After restart
	0- No action. 1- Write motor parameters to encoder EEPROM: After modifying the motor parameters, you need to perform this operation to write the data to the encoder. 2- Clear multi-turn encoder laps: if you use it initially or replace or insert/remove the battery during power-down of the drive. After power on, an encoder backup alarm (Er. 810) will be reported. This parameter is set to 2 in the servo disable status (after setting it to 2, the parameter will be Automatically return to 0, this is a normal phenomenon) and it can only be cleared after re-powered. The alarm clearing will					

	clear the encoder multi-turn value at the same time, and the single-turn value will be retained.
--	--

Related monitoring data:

Monitoring code	Monitoring name	Range	Unit	Communication address
Un010	Absolute encoder single-turn value	0x80000000 ~ 0x7ffffff	Encoder pulse unit	0xE011
	Displays the single-turn absolute position of the absolute encoder.			
Un011	Absolute encoder multi-turn value	0x80000000 ~ 0x7ffffff	Encoder pulse unit	0xE011
	Display the number of turns of the multi-turn encoder when the multi-turn encoder is used. After the multi-turn encoder reset operation is performed, the value is 0.			



1. When replacing the battery, please do it when the drive is powered on and the encoder line is connected normally, otherwise the encoder backup warning will be reported when it is connected again, at which time the absolute position is lost and it is necessary to clear the multi-turn encoding circle action again.

5.1.9 Torque Limit

1. Torque limit method

For the purpose of protecting the machine etc., the output torque can be limited and set by parameter Pn050. The torque limit can be set in the following five ways:

Pn050	Torque limit method description	Related parameters
0	Analog torque (torque mode is invalid)	Pn405
1	Maximum torque limit 1	Pn051
2	Positive torque limit 1 (Pn051), reverse maximum torque limit 2	Pn051 Pn052
3	Maximum torque limit 1 when the torque limit switching (/TLC) signal is OFF; Maximum torque limit 2 when ON.	Pn051 Pn052
4	Restricted by internal torque command (effective in torque mode)	Pn410



1. The input voltage of the analog command for torque limiting has no polarity. The absolute value of the voltage is taken, and the torque limiting value corresponding to that absolute value is used in both the forward direction and the reverse direction.
2. If the set value exceeds the maximum torque of the servo motor used, the actual torque is also limited to ..

2.Torque limit output signal

The torque limit (/CLT) output is ON means the motor output torque is in the limit state. This signal can be used to confirm the status of the current torque limit of the motor. Refer to “Sequence Output Circuit” for the wiring method. Refer to “Switching Output Signal” for parameter setting.

3.Torque limit under voltage

When the instantaneous power failure and the main circuit power supply voltage are insufficient for a short period of time, the main circuit DC voltage inside the servo unit is below the specified value, an under-voltage warning is detected, and the function for limiting the output torque can be selected. Related parameters are as below:

Function code	Parameter	Range	Default	Unit	Communication address	When enabled
Pn045	Under-voltage function selection	0x00 ~ 0x02	0	—	0x0045	After restart
	0 - No Detection of Main Circuit Descent Warning. 1 - Detection of Main Circuit Descent Warning. 2 - Detect main circuit down warning and perform torque limit. The relevant torque limit is matched with Pn046/Pn047. For details, refer to “Main circuit under-voltage torque limit”.					
Pn046	Torque limit when main circuit voltage drops	0 ~ 100	50	%	0x0046	Immediately
	According to the under voltage warning, it will impose the torque limit inside the servo unit.					
Pn047	Torque limit release time when main circuit voltage drops	0 ~ 1000	100	ms	0x0047	Immediately
	After the under-voltage warning signal releases, the torque limit value is controlled within the servo unit according to the set time. For details, see “Under-voltage limit of the main circuit”.					

By combining this function with the setting function of the instantaneous stop holding time, when the power supply voltage is insufficient, it is possible to avoid the shutdown due to the alarm and continue the operation without performing the power restoration operation.

Under-voltage warning, apply torque limit inside the servo unit. After receiving the under voltage warning release signal, the torque limit value is controlled within the servo unit according to the set release time. The logical timing is as follows:

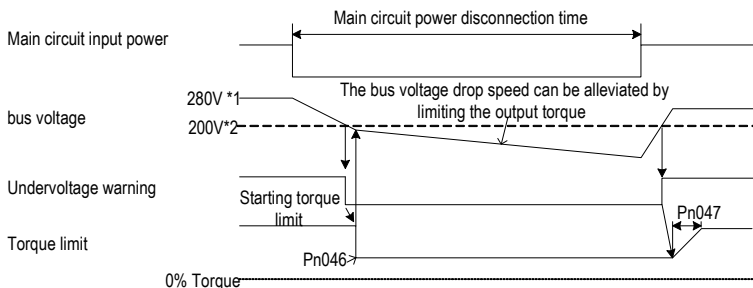

1: 560V at 400VAC

2: 400V at 400VAC

5.2 Position Mode

For details on the wiring related to the position mode; see “Connection Control Example for Position Control”. The position control is selected by the control mode selection (Pn000 = 0, factory default).

5.2.1 Quick Guide

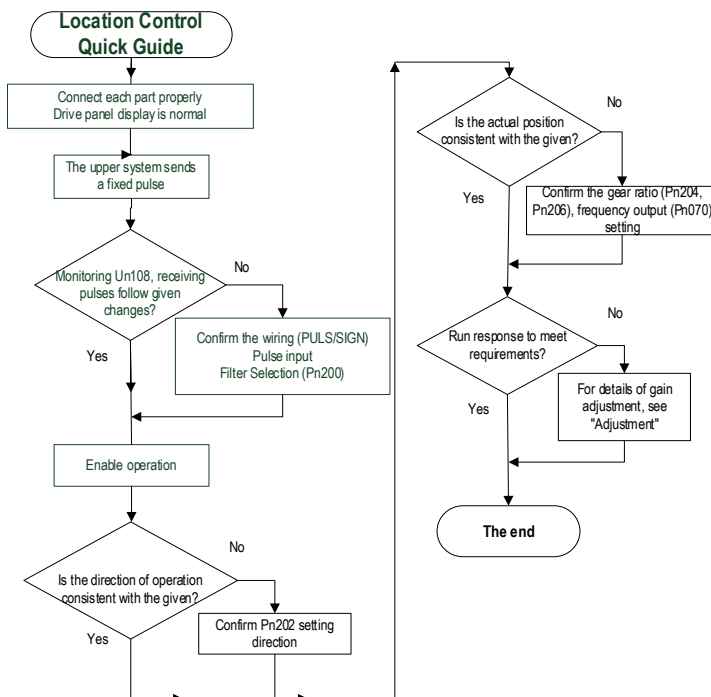

5.2.2 Basic Settings











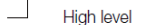

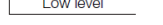
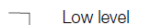

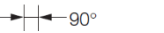

The following describes the basic settings for position control:

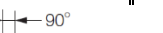
1. Command pulse filter selection

The appropriate command pulse filter can be selected according to the frequency of the highest pulse in operation, which can be set by parameter Pn200. For details, refer to the relevant description of the function code. If the selection is not appropriate, the received pulse of the servo unit may be lost or increased.

2. Pulse input form

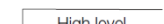
According to the pulse output form of the upper system, the pulse input form of the servo unit is selected.

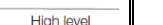
Function code	Setting value	Order form	Forward instruction	Reverse instruction
Pn201	0	Pulse + direction positive logic	PULS (CN1-7)  SIGN (CN1-11)  High level	PULS (CN1-7)  SIGN (CN1-11)  Low level
	1	CW+CCW positive logic	CW (CN1-7)  Low level CCW (CN1-11) 	CW (CN1-7)  CCW (CN1-11)  Low level
	4	Quadrature encoding 4 times	 90° Phase A  Phase B 	 90° Phase A (CN1-7)  Phase B (CN1-11) 
	5	Pulse + direction negative logic	PULS (CN1-7)  SIGN (CN1-11)  Low level	PULS (CN1-7)  SIGN (CN1-11)  High level
	6	CW+CCW negative logic	CW (CN1-7)  High level CCW (CN1-11) 	CW (CN1-7)  CCW (CN1-11)  High level

3. Electronic gear ratio

When the reduction ratio of the motor shaft and the load side is n/m (when the load shaft rotates by n revolutions when the motor rotates by m revolutions), the set value of the electronic gear ratio

can be obtained by the following formula:

$$\text{Electronic gear ratio} \frac{B}{A} = \frac{Pn204}{Pn206}$$

$$= \frac{\text{Encoder resolution}}{\text{Load shaft movement amount in 1 rotation (command unit)}} \times \frac{m}{n}$$

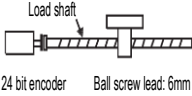
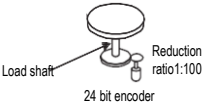
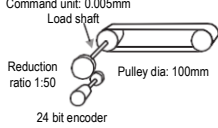
Steps	Content	Mechanical system		
		Ball screw	Rotary table	Belt + Pulley
		<p>Command unit: 0.001mm</p>  <p>24 bit encoder Ball screw lead: 6mm</p>	<p>Command unit: 0.01°</p>  <p>24 bit encoder Reduction ratio 1:100</p>	<p>Command unit: 0.005mm</p>  <p>24 bit encoder Pulley dia: 100mm Reduction ratio 1:50</p>
<p>Ball screw lead: 6mm Reduction ratio: 1/1</p>	<p>Rotation angel per turn: 360° Reduction ratio: 1/100</p>	<p>Pulley dia: 100mm (Pulley circumference 314mm) Reduction ratio: 1/50</p>		
1	Machine specification			
2	Encoder resolution	8388608 (23 bit) 16777216 (24 bit) 131072 (17 bit)	83886708 (23 bit) 16777216 (24 bit) 131072 (17 bit)	8388608 (23 bit) 16777216 (24 bit) 131072 (17 bit)
3	Command unit	0.001mm (1mm)	0.01°	0.005mm (5mm)
4	Load shaft movement in 1 rotation (command unit)	6mm/0.001mm = 6000	360°/0.01° = 36000	314mm/0.005mm = 62800
5	Electronic gear ratio	$\frac{B}{A} = \frac{83388608}{6000} \times \frac{1}{1}$	$\frac{B}{A} = \frac{83388608}{36000} \times \frac{100}{1}$	$\frac{B}{A} = \frac{83388608}{62800} \times \frac{50}{1}$
6	Parameters	Pn204: 8388608	Pn204: 838860800	Pn204: 419430400
		Pn206: 6000	Pn206: 36000	Pn206: 62800



1. Electronics gear ratio numerator (Pn204) set to 0, electronic gear ratio than the denominator (Pn206) set the value of the number of pulses corresponding to the motor running one lap, for example, Pn204 (numerator) set to 0, Pn206 (Denominator) set to 10000, it means that the upper computer (PLC, motion controller, etc.) send 10000 pulses servo motor turn one lap.

2. $0.001 \leq \text{electronic gear ratio } (B/A) \leq 83887$ beyond this setting range, "Parameter Setting abnormality (Er.040) alarm" (for 23 bit encoder).

5.2.3 Deviation Clearance

The deviation clear signal (/CLR) is the input signal to clear the servo unit deviation counter.

1. Clear signal wiring

Deviation clear signal wiring can be divided into linear driver output and open collector output. Please refer to "Position Command Input Circuit" for wiring details.

2. Setting the deviation clear mode

The shape of the clear signal is set by Pn272.

Function code	Parameter	Range	Default	unit	Communication address	When enabled
Pn272	Position deviation clear mode	0x00 ~ 0x03	0	—	0x0272	Power down effective
	Set the clear mode of the digital position deviation clear signal (/CLR): 0-level clear when cleared. 1-rising edge OFF->ON clear. 2-Clear when 2-level OFF. 3-falling edge clears when ON->OFF.					

When Pn272 = 0 or 2, in order to perform clear signal processing, the amplitude of the clear signal must be 250µs or more.

When Pn272 = 1 or 3, in order to perform clear signal processing, the amplitude of the clear signal must be 20µs or more.



If the setting is set to hold clear, the servo lock function is invalid. As a result, the servo motor will rotate slightly due to drift pulses in the speed loop.

3. Deviation clearing method selection

Depending on the status of the servo unit, you can choose when to clear the position deviation. Set the deviation clearing method by Pn273:

Function code	Parameter	Range	Default	Unit	Communication address	When enabled
Pn273	Position deviation clear mode	0x00 ~ 0x02	0	—	0x0273	Power down effective
	Set themode of the deviation clearing: 0-Servo OFF, alarm, / CLR signal position deviation can be cleared. 1-/CLR signal position deviation can be cleared.					

	2-Alarm/CLR signal position deviation can be cleared. 3-Cleared in case of servo OFF, alarm and limit. 4-Not clearing the position deviation. 5-Cleared in case of servo OFF, alarm and limit.
--	---

See the “Deviation Clearance” for details on the pulse amplitude of the clear signal.

In position control, the positional deviation remains unchanged when the servo motor is stopped due to the travel limit.



When the position mode is running, the servo motor stops due to the travel limit. If the upper computer continues to send pulses at this time, the position deviation will keep increasing and the position deviation will not be cleared automatically, which may cause the motor to fly when the travel limit is excluded.

5.2.4 Command Pulse Prohibition

The command pulse inhibition (/INHIBIT) function is a function that prohibits the command pulse input from being counted during position control. When this function is enabled, the servo unit enters a state where it cannot receive the command pulse input.

1. Configuration of Command Pulse Prohibition

The signal is not configured in the factory default switch configuration. Therefore, the pin number configuration (0x0D) needs to be performed by parameters Pn601 ~ Pn609.

2. Command pulse inhibited wiring

The command pulse disable signal is a universally configurable digital input. See “Sequence Input Circuit” for wiring details.

5.2.5 Positioning Approach

When positioning is close to (/NEAR) position control, the host device may receive the positioning proximity signal before confirming the positioning completion signal, so as to prepare for the sequence of actions after the positioning is completed. In this way, the time required to complete the positioning can be shortened. This signal is usually used in pair with the positioning completion signal. Refer to the “Positioning completed” instruction for the positioning completion signal.

1. Positioning close to the configuration

The signal is not configured in the factory default digital output configuration. Therefore, the pin number configuration (0x08) needs to be performed by parameters Pn613 ~ Pn615.

When the difference between the command pulse number of the host device and the movement amount of the servo motor (position deviation) is lower than the setting value of Pn260 (position proximity signal width), the signal is output when the positioning close output condition is satisfied.

2. Locating close wiring

The positioning proximity signal is a universally configurable digital output. See “Sequence Output Circuit” for wiring details.

5.2.6 Positioning Completion

In position control, it indicates the servo motor positioning completed (/COIN) signal.

1. Positioning completed configuration

In the factory default digital output configuration, the signal is configured as CN1's 27th and 28th pin numbers (Pn614=0x01) by default. Please confirm before use.

Function code	Parameter	Range	Default	Unit	Communication address	When enabled
Pn262	Positioning completion range	0 ~ 1073741824	7	Command unit	0x0262 0x0263	Immediately
	In the position control, the servo motor positioning completion signal will be output when the difference between the command pulse number from the host device and the servo motor movement amount (position deviation) is lower than the set value that means the host device confirming positioning has been completed.					

If the set value is too large, the permanent positioning completion signal may be output when the deviation is small during low-speed operation. When outputting a constant positioning signal, please lower the setting until the signal is no longer output.

Function code	Parameter	Range	Default	Unit	Communication address	When enabled
Pn274	Positioning completion signal output time	0x00 ~ 0x02	0	—	0x0274	Immediately
	Set the output timing of the positioning completion signal /COIN: 0- Output when the absolute value of position deviation is less than the positioning completion range (Pn262). 1- Output when the absolute value of the position deviation is smaller than the positioning completion range (Pn262) and the command after the position command filtering is 0. 2- Output When the absolute value of the position deviation is smaller than the positioning completion range (Pn262) and the positioning command input is 0.					

2. Positioning completion wiring

The positioning completion signal is a universally configurable digital output. For wiring details, refer to “Sequence Output Circuit”.

Example of optocoupler circuit

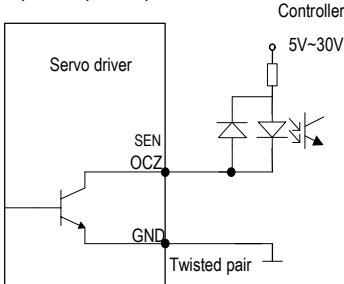

Example of relay circuit

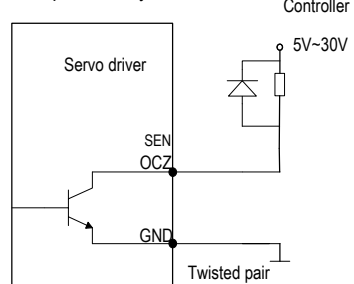

5.2.7 Command Pulse Input Magnification Switching

The ON/OFF of the override input switching signal (/PSEL) of the command pulse input switches the input override of the position command pulse to 1 and n times (n = 1 to 100). The switching of the override can be confirmed by the command pulse input of the override switching output signal (/PSELA).

Please switch the command pulse magnification while the position command pulse is 0. If the position command pulse is not 0, the servo motor may cause a position error or cause a position loss.

1. Configuration of command pulse input magnification switching

The signal is not configured in the factory default digital input configuration. Therefore, the pin number configuration (0x10) needs to be performed by parameters Pn601 ~ Pn609.

Function code	Parameter	Range	Default	Unit	Communication address	When enabled
Pn203	Command pulse input magnification	1 ~ 100	1	x1 times	0x0203	Immediately
	Set the command pulse input magnification value to be used in conjunction with ON/OFF of the command pulse magnification switching signal for switching the position command pulse input magnification to 1 and the parameter setting multiple. Note: The input pulse frequency is too low. If the value is set too large, the speed may not be steady.					

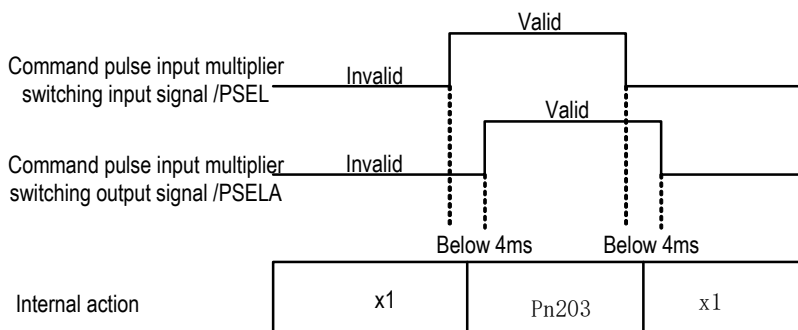

2. Command pulse input magnification switching wiring

The command pulse input override signal is a universally configurable digital input. See “Sequence Input Circuit” for wiring details.

5.2.8 Smooth Settings

The command pulse input is filtered to make the rotation of the servo motor smoother. This function is more effective in the following situations:

- The host device that issued the command does not perform acceleration / deceleration.
- When the instruction pulse frequency is extremely low.
- When the position command smoothing function is set, the system response may be affected. Please use it reasonably.

The filter-related parameter settings are as follows:

Function code	Parameter	Range	Default	Unit	Communication address	When enabled
Pn211	Position command low-pass filter time constant	0 ~ 655	0	ms	0x0211	After stop
	This parameter is used to set the time constant of the first-order low-pass filter corresponding to the position command and it can reduce the mechanical shock in the case of abrupt changes in the input pulse command frequency by setting this parameter. If set too large, the servo response will slow down.					
Pn212	Moving average filtering time of position command	0 ~ 1000	0	ms	0x0212	After stop
	This parameter is used to set the time constant of the moving average filter of the corresponding position instruction. It can reduce the mechanical shock in the case of abrupt changes in the input pulse command frequency by setting this parameter. If set too large, the servo response will slow down.					

The difference between the position command low-pass filter time constant and the position command's moving average filter time is shown below:

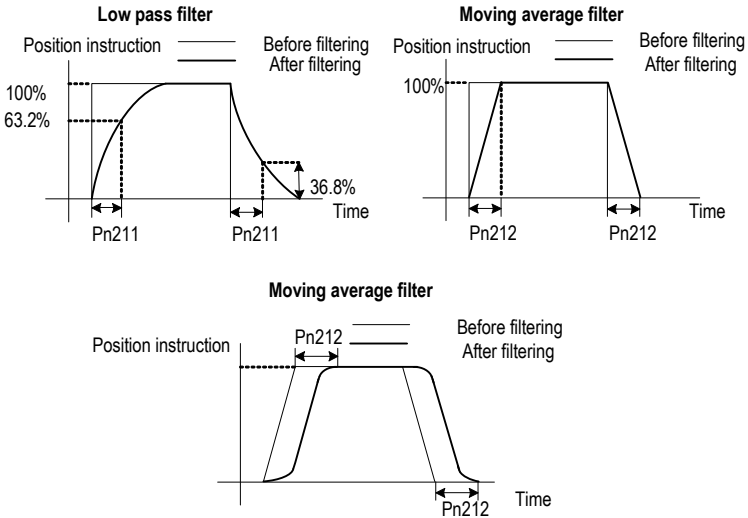

5.2.9 Frequency-division Output

The encoder frequency-divided pulse output is a signal that is output to the outside in the form of a two-phase pulse (phase A, phase B) with a phase difference of 90° after processing the signal from the encoder inside the servo unit. Used as position feedback in the host device.

Frequency-division pulse output parameter configuration

How to set the encoder frequency pulse output as follows:

Function code	Parameter	Range	Default	Unit	Communication address	When enabled
Pn070	Encoder divider pulses	16 ~ 4194304	2048	0x0070	After restart	
	The number of pulses per cycle from the encoder is divided by frequency in accordance with the set value of this parameter. Please set it according to the system specifications of the machine and host device.					
Pn072	Divided frequency output reversed	0 ~ 1	0	-	0x0072	After restart

<p>A/B pulse phase sequence logic when setting forward/reverse: 0- Don't revert the pulse output: When forward, A leads B. 1- 1- Revert the pulse output: When forward, B leads A .</p>

1. Frequency division pulse

The number of pulses per revolution from the encoder is processed inside the servo pack and then divided down and output to the set value of Pn070.

The encoder's number of divided pulse outputs is set according to the system specifications of the machine and the host device.

The setting of frequency division pulse number of encoder will be limited by the resolution of encoder. The maximum output frequency of frequency division pulse of encoder shall not exceed 4MHz (after 4 times frequency), as shown in the table below:

Pulse Number of Encoder Frequency Devision (pulse/r)	Setting increment	Encoder Resolution			Upper Limit of motor Speed (r/min)
		17 bits	20 bits	23 bits	
16 ~ 16384	1	o	o	o	6000
16386 ~ 32768	2	o	o	o	3000
32772 ~ 65536	4	o	o	o	1500
65544 ~ 131072	8	o	o	o	750
131088 ~ 262144	16	-	o	o	375
262176 ~ 524288	32	-	o	o	187
524352 ~ 1048576	64	-	o	o	93
1048704 ~ 2097152	128	-	-	o	46
2097408 ~ 4194304	256	-	-	o	23

Output example: When Pn070=16 (16 pulses per revolution), an example of the output of the encoder-divided pulse output A-phase (PAO) signal and the encoder-divided pulse output B-phase (PBO) signal is shown below.

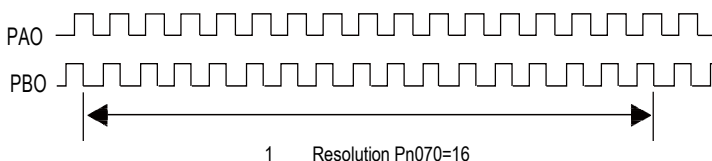

2. Frequency division output reversed

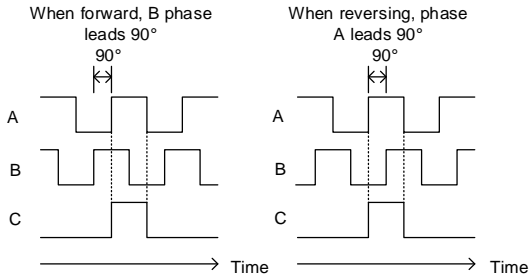

Parameter Pn072 can be set to revert the logic of the AB phase signal of the divided output pulse.

The amplitude of the Z-phase pulse varies with the number of encoder frequency-division pulses (Pn070) and is consistent with the amplitude of the A-phase. The smaller the frequency division pulse number (Pn070) is, the wider the Z-phase pulse amplitude is.

Frequency division pulse output wiring

Refer to the “Linear Drive Output Circuit” for details on the wiring of the frequency division pulse output.

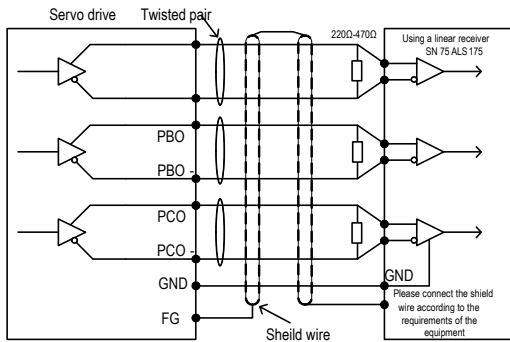

The voltage of the encoder divider pulse output is differential $\pm 5V$, the C (Z) phase pulse is very small because of the pulse width, so it is difficult to measure the change with a multimeter, and it needs to cooperate with the high-speed input point of the upper computer to capture the pulse, or the number of encoder divider pulses (Pn070) can be set to the minimum (16), and then cooperate with the multimeter voltage file to measure.

5.3 Speed Mode

For details on speed mode wiring, see “Speed Control Connection Example”. It is selected by control mode selection (Pn000).

The speed control mode is divided into internal speed mode (Pn000=3) and analog speed mode (Pn000=1) according to the command source.

5.3.1 Quick Guide

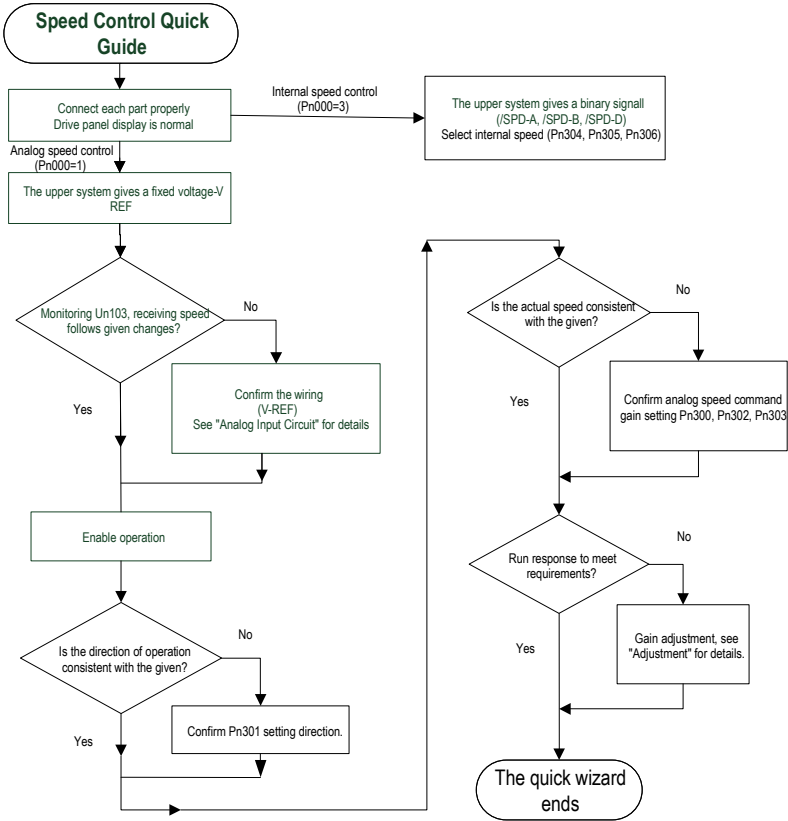

5.3.2 Basic Settings

Control mode selection (Pn000=3), internal speed mode, internal speed command direction selection based on digital input (/SPD-D) internal speed command selection A (/SPD-A), internal speed command selection B (/SPD- B) configuration to select the speed instruction.

The control mode selection (Pn000 = 1) is the analog speed mode. The speed command is given according to the voltage of V-REF (CN1-5, CN1-6) and the set value of analog speed command gain Pn300.

The basic settings for these two modes are described below:

1. Analog speed

Function code	Parameter	Range	Default	Unit	Communication Address	When enabled
Pn300	Analog speed command gain	150 ~ 3000	600	0.01V / rated speed	0x0300	Immediately
	This parameter is used to set servo motor speed that should be equal to analog voltage value (V-REF) required for the speed command of the rated value. Caution: Do not apply more than -10V ~ 10V and exceeding this range may cause damage to the driver.					
Pn301	Analog speed command negation	0 ~ 1	0	-	0x0301	Immediately
	Set the voltage polarity of the analog speed command: 0-Positive polarity: positive voltage corresponds to positive speed command. 1- Negative polarity: positive voltage corresponds to negative speed command.					
Pn302	Analog speed instruction filter time	0 ~ 655.35	0.40	ms	0x0302	Immediately
	The function could be set to smooth the speed command when one delay filter is applied to the analog speed command (V-REF) input and it does not usually need to be changed. If the set value is too large, the responsiveness may decrease. Please set this parameter while confirming the response.					
Pn303	Analog speed command dead zone range	0 ~ 3	0	V	0x0303	Immediately
	In the analog speed control, even if the input command is 0V, the servo motor may rotate at a slight speed. This is because there is a slight deviation in the commands inside the servo unit. This error can be eliminated by setting an appropriate analog speed command deadband range.					

Set the analog voltage value of the speed command (V-REF, see "Analog Input Circuit" for wiring) that makes the speed of the servo motor rated as the analog speed command gain Pn300.

Example: The factory default parameter Pn300 = 600 (6V corresponds to the rated speed (assuming 3000rpm). If the V-REF input voltage is 1V, the speed command corresponds to 500rpm. If 3V is input, the speed command corresponds to 1500rpm.

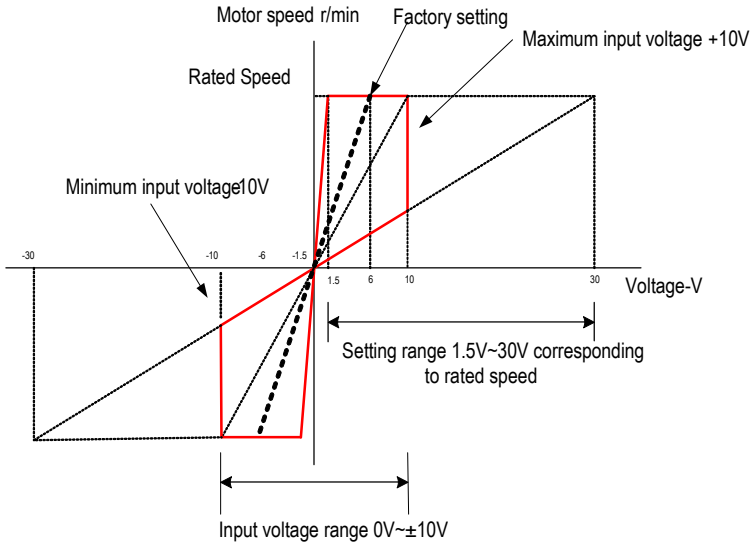

Adjustment of instruction offset

When analog speed control is used, even if the command is 0V, the servo motor may rotate at a slight speed. This is because there is a slight deviation in the instructions inside the servo unit. This slight deviation is called "offset".

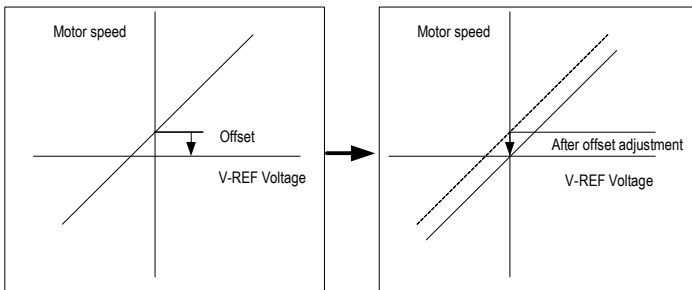

There are two methods of automatic adjustment and manual adjustment of offset adjustment. Automatic adjustment is automatic adjusting command offset (Fn100) and manual adjustment is manually adjusting command offset (Fn101). For details, see "Auxiliary Functions".



1. For automatic adjustment, be sure to adjust the command bias amount in the state of servo OFF and the upper computer (PLC, knob, etc.) giving 0v voltage command.
2. When adjusting manually, observe the operation of the motor while adjusting in the state of servo ON.
3. If the factory setting is restored, the offset adjustment value will not be initialized.

2. Internal speed

Function code	Parameter	Range	Default	Unit	Communication address	When enabled
Pn304	Internal speed 1	0 ~ 10000	100	rpm	0x0304	Immediately
	Internal speed 2	0 ~ 10000	200	rpm	0x0305	Immediately
Pn305	Internal speed 3	0 ~ 10000	300	rpm	0x0306	Immediately
Pn306	When operating in the internal speed mode, the servo unit provides 3 internal speed commands and selects A and B through the switching value internal speed command. When the switching value internal speed command selects A and B at OFF state, the internal speed is default as 0.					

The speed is selected through the digital input signal control:

Switching value input signal			Direction of speed instruction	Speed instruction
/SPD-D	/SPD-A	/SPD-B		
OFF	OFF	OFF	Positive	0
	OFF	ON		Internal speed 1(Pn304)
	ON	ON		Internal speed 2(Pn305)
	ON	OFF		Internal speed 3(Pn306)
ON	OFF	OFF	Negative	0
	OFF	ON		Internal speed 1(Pn304)
	ON	ON		Internal speed 2(Pn305)
	ON	OFF		Internal speed 3(Pn306)

5.3.3 Soft Start

The soft start function is a speed command that converts a step speed command to a smoother constant acceleration/deceleration. You can set the acceleration time and deceleration time, and use this function when you want to achieve smooth speed control during speed control.

Function code	Parameter	Range	Default	Unit	Communication address	When enabled
Pn310	Speed command trapezoidal acceleration time	0 ~ 10000	0	ms	0x0310	Immediately
	Acceleration time of the set speed is from 0r/min to the max speed (corresponding to the motor model). When the given speed is more or less than the max speed, the actual acceleration time is calculated in proportion.					
Pn311	Speed command	0 ~	0	ms	0x0311	Immediately

	trapezoidal deceleration time	10000				
Deceleration time of the set speed is from max speed (corresponding to the motor model) to 0r/min. When the given speed is more or less than the max speed, the actual deceleration time is calculated in proportion.						

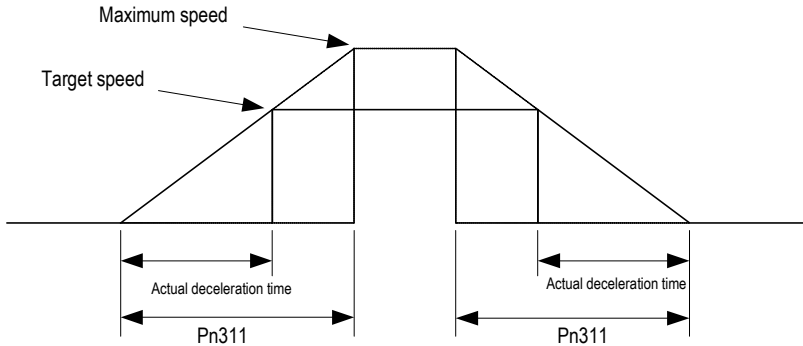

Note that the acceleration and deceleration time refers to the acceleration from 0 to the maximum speed or deceleration from the maximum speed to 0. It is judged by the maximum speed and not by the rated speed or the given speed.

5.3.4 Zero Fixed Functions

The zero-fixed function means that when the zero-position fixed signal (/ZCLAMP) is ON, the servo lock is performed when the input voltage of the speed command (V-REF) is lower than the speed set by the fixed zero value (Pn501). At this time, the position loop is formed inside the servo unit, and the speed command will be ignored. Therefore, when used for speed control, the host device does not build a position loop.

The servo motor is fixed within ± 1 pulse of the zero position fixing effective position. Even if rotation occurs due to external force, it will return to the zero position.

1. Zero-fixed configuration

The signal is not configured in the factory default switch configuration. Therefore, the pin number configuration (0x0C) needs to be performed by parameters Pn601 ~ Pn609.

Function code	Parameter	Range	Default	Unit	Communication address	When enabled
Pn312	Zero speed clamp mode	0 ~ 3	3	-	0x0312	Immediately

	Speed mode, setting the switching speed zero clamp signal (/ZCLAMP) working mode: 0- Invalid. 1- Speed command is set to 0, not clamped after shutdown. 2- Speed command is set to 0, clamped after shutdown. 3- Speed command is lower than “zero position clamp speed threshold”, and then speed command is set to 0 at first, clamped after stop.					
Pn313	Zero Speed Clamp Speed Threshold	0 ~ 10000	10	rpm	0x0313	Immediately
	Set the zero control switching threshold when “zero speed clamp mode”(Pn312) is set to 3.					

The relationship between zero fixed speed thresholds and zero fixed function is shown in the figure below:

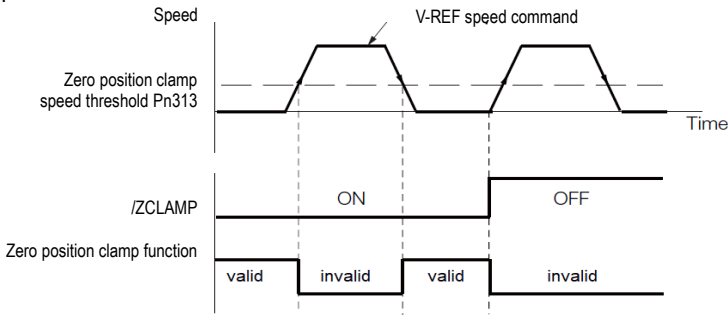

2. Zero-fixed wiring

The zero-fixed signal is a universally configurable digital input. See “Sequence Input Circuit” for wiring details.

5.3.5 Rotation Detection Signal

When the motor speed is greater than the set value, a digital rotation detection signal (/TGON) is output.

1. Configuration of rotation detection signal

Function code	Parameter	Range	Default	Unit	Communication address	When enabled
Pn317	Rotation determination threshold	1 ~ 10000	20	rpm	0x0317	Immediately
	When the motor speed is higher than the set value, the switch rotation detection signal (/TGON) is output.					

This signal is not configured in the factory default digital output configuration. Please confirm before

use.

The signal is not configured in the factory default digital output configuration. Therefore, the pin number configuration (0x03) needs to be performed by parameters Pn613~Pn615.

The output condition is that the signal is output when the current feedback speed (absolute value) of the motor is higher than the setting value of Pn317 (rotation determination threshold).

2. Wiring of rotation detection signals

The rotation detection signal is a universally configurable digital output signal. See “Sequence Output Circuit” for wiring details.

Example of optocoupler circuit

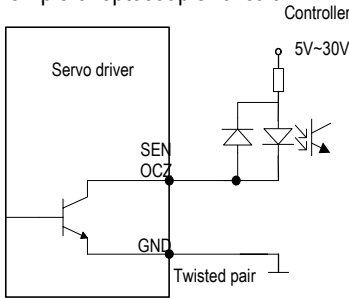

Example of relay circuit

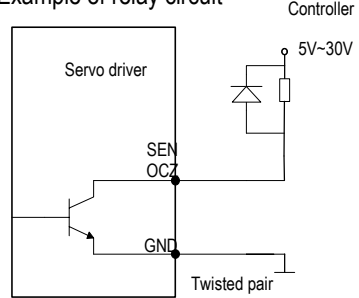

5.3.6 Consistent Speed

The speed coincidence signal (*V-CMP*) is a signal that is output when the difference between the speed of the servo motor and the command speed is equal to or lower than the set value of the speed coincidence range Pn320. Used when interlocking with the upper device. This signal is the output signal during speed control.

1. Configuration of Speed-consistent Signals

Function code	Parameter	Range	Default	Unit	Communication address	When enabled
Pn320	Speed consistent range	0 ~ 100	10	rpm	0x0320	Immediately
	When the difference between the motor speed and the command speed is lower than the set value, the switch-speed match signal (<i>V-CMP</i>) is output.					

In the factory default digital output configuration, the signal is configured as CN129 and 30 pin numbers (Pn614=0x02) by default. Please confirm before use.

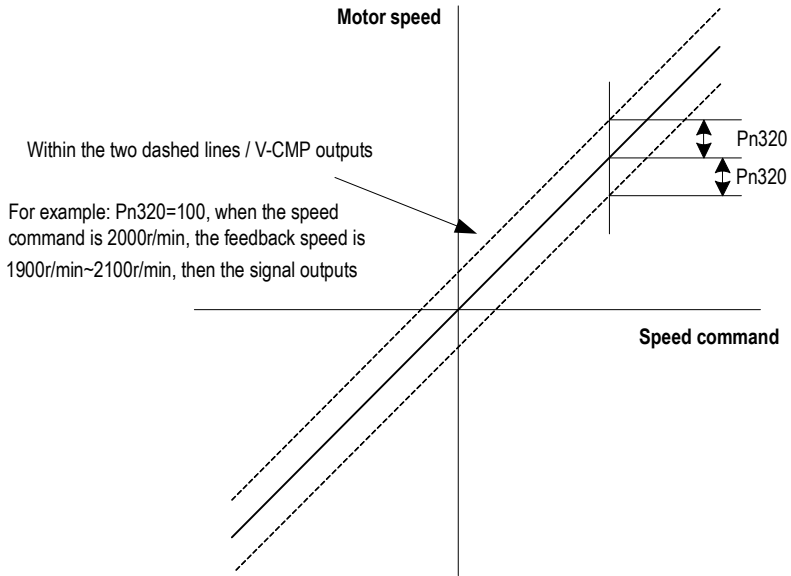

2. Wiring of speed-consistent signals

The speed-consistent signal is a universally configurable digital output signal. For details on wiring, see “Sequence Output Circuit”.

5.4 Torque Mode

Refer to “Connection Example of Torque Control” for details on the wiring related to the torque mode. It is selected by control mode selection (Pn000=2). The torque mode is divided into the internal torque command (Pn400=0) and the analog torque command (Pn400=1, factory default) by the selection of the torque command source.

5.4.1 Quick Guide

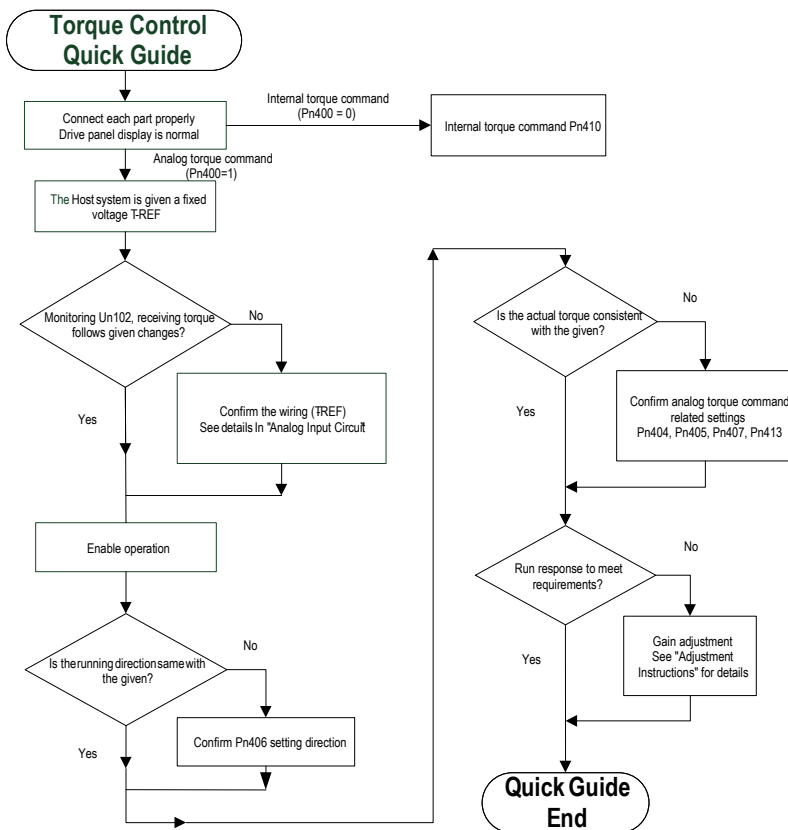

5.4.2 Basic Setting

Torque control is the operation method of inputting the torque command to the servo unit and controlling the output of the servo motor through the size of the torque command.

When (torque command selection source) $pn400 = 0$, the internal torque command gives the torque, and the torque value is directly set by the parameter $pn410$. In this way, the internal torque can be given by writing the address 0x0410 through RS-485. When $pn400 = 1$, it is an analog torque command, and the torque command is given according to the voltage connected to t-ref (cn1-9, cn1-10) and the set value of $pn405$ (analog torque command gain).

Function code	Parameter	Range	Default	Unit	Communication address	When enabled
Pn400	Torque command selection	0~1	1	-	0x0400	Immediately
	Select the command source of Torque control: 0 – Internal setting. 1 – Analog setting.					
Pn404	Analog torque command filter time	0~655.35	0.00	ms	0x0404	Immediately
	The parameter is used to smooth the torque command when we apply a delay filter to the analog torque command (T-REF) input, usually it does not need to be changed. If the set value is too large, the responsiveness may decrease. So please set it up as we check the response.					
Pn405	Analog torque command gain	10~100	30	0.1V /Rated Torque	0x0405	Immediately
	This parameter is used to set the analog voltage value (T-REF) required for the rated torque of the servo motor. Note: Do not apply a voltage above -10V~10V. exceeding this range may damage the drive.					
Pn406	Analog torque command inversion	0~1	0	-	0x0406	Immediately
	Analog voltage corresponds to the polarity setting of the torque command: 0- Positive polarity: Positive voltage corresponds to positive torque command. 1- Negative polarity: Positive voltage corresponds to negative torque command.					
Pn407	Analog torque command dead-zone range	0~3	0	V	0x0407	Immediately
	In analog torque control, even if the input command is 0V, the servo motor may rotate at a slight speed. This is because a slight deviation occurs in the command inside the servo. This deviation can be eliminated by setting an appropriate analog torque command dead-zone range.					
Pn410	Internal torque command in torque control	-500~500	0	%	0x0410	Immediately
	Set the internal torque command value during torque control.					

Example:

The factory default parameter Pn405=30 (3V corresponds to the rated torque). If the input voltage at the T-REF terminal is 1.5V, the torque command corresponds to 50%. If 3V is input, the torque command corresponds to 100%.

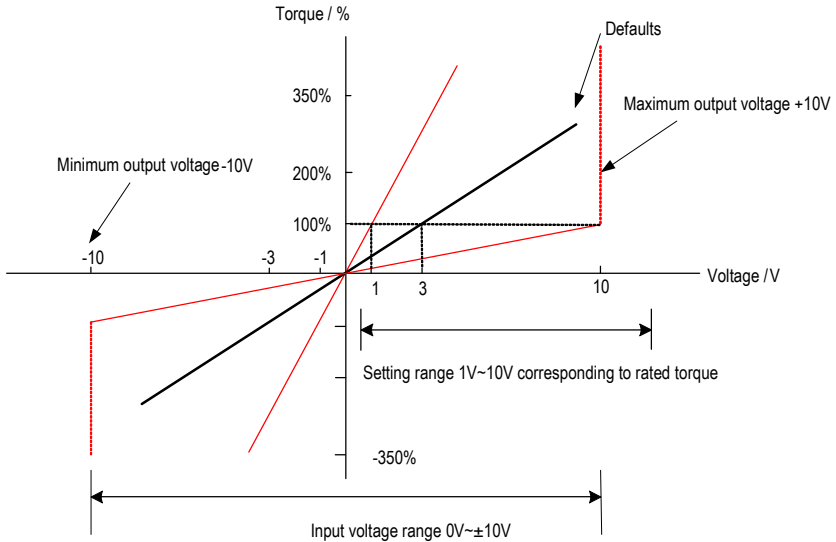

5.4.3 Adjustment of Command Offset

When using torque control, even if the command is 0V, the servo motor may rotate at a slight speed. This is because there is a slight deviation in the Commands inside the servo unit. This slight deviation is called "offset".

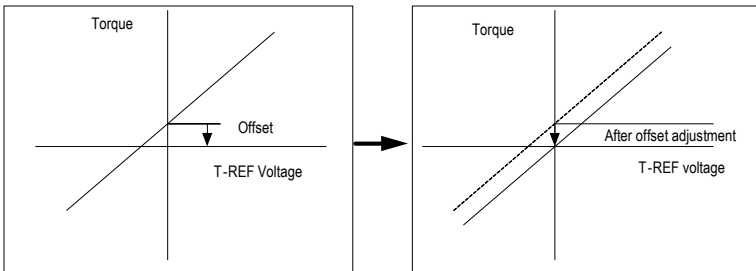

There are two methods of automatic adjustment and manual adjustment of offset adjustment. Automatic adjustment is automatically adjusting the command offset (Fn100) and manual adjustment is manually adjusting using command offset (Fn102). For details, see "Auxiliary Functions".



1. For automatic adjustment, be sure to adjust the command bias amount in the state of servo OFF and the upper computer (PLC, knob, etc.) giving 0v voltage command.
2. When adjusting manually, observe the operation of the motor while adjusting in the state of servo ON.
3. If the factory setting is restored, the offset adjustment value will not be initialized.

5.4.4 Speed Limit in Torque Control

A function to limit the speed of the servo motor to protect the machine.

During torque control, the servo motor is controlled to output a given torque command, but the motor speed is not controlled. Therefore, when the input command torque is greater than the load torque, the motor speed will increase significantly. In this case, the speed needs to be limited by this function.

5.5 Hybrid Control Mode Selection

The servo unit can combine the two modes from various control modes and switch them. The control mode is selected by Pn000. The following describes the switching method and switching conditions.

Function code	Parameter	Range	Default	Unit	Communication address	When enabled
Pn000	Control mode selection	0 ~ 11	0	-	0x0000	After restart
	4 - Internal speed <-> Analog speed: Switch control mode via ON/OFF of switch /SPD-A and /SPD-B. 5 - Internal speed <-> Position mode: Switch control mode via ON/OFF of switch /SPD-A and /SPD-B. 6 - Internal speed <-> Torque mode: Switch control mode via ON/OFF of switch /SPD-A and /SPD-B. 7 - Position Mode <-> Analog speed: Switch the control mode through ON/OFF of the switch control mode switch (/C-SEL) signal. 8 - Position mode <-> Torque mode: Switch the control mode through ON/OFF of the switch control mode switch (/C-SEL) signal. 9 - Torque Mode <-> Analog Speed: ON/OFF Switching Control Mode of (C-SEL) Signal Switching Mode. 10 - Analog speed <-> Zero function of speed mode: When control speed, zero fixed function can be used. 11 - Position Mode <-> Position mode of command pulse disabled: When Control position, command pulse disable function can be used. 16 - EtherCAT mode.					

1. Internal speed control switching (Pn000 = 4, 5, 6)

a) The digital input signal distribution mode is internally fixed (Pn600=0). The control mode (second mode) and internal set speed can be switched by the /SPD-A and /SPD-B signals.

Digital input signal			Speed command positive and negative	Pn000 setting		
/SPD-D (CN1-41)	/SPD-A (CN1-45)	/SPD-B (CN1-46)		4	5	6
OFF	OFF	OFF	Second mode determines	Analog speed mode	Position mode	Torque mode
	OFF	ON	Positive	Internal speed 1 (Pn304)		

	ON	ON		Internal speed 2 (Pn305)		
	ON	OFF		Internal speed 3 (Pn306)		
ON	OFF	OFF	Second mode determines	Analog speed mode	Position mode	Torque mode
	OFF	ON	Negative	Internal speed 1 (Pn304)		
	ON	ON		Internal speed 2 (Pn305)		
	ON	OFF		Internal speed 3 (Pn306)		

No limits for each mode switch. While motor running, speed control, position control or torque control can be switched to internal setting speed control.

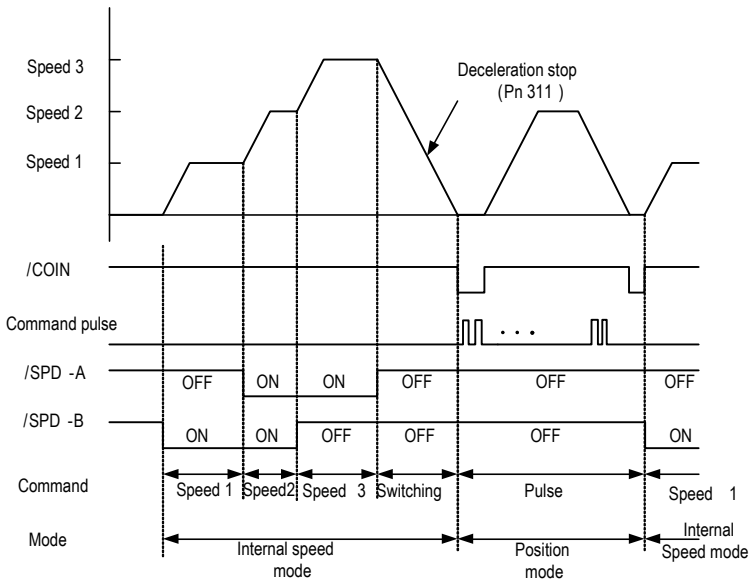

Note : The internal speed mode is decelerated during the deceleration time set by Pn311 to stop the motor, then switch to the position mode

b) Digital input signal distribution mode is parameter configuration (Pn600=1 default parameter)

Through the ON/OFF switching control mode of the control mode switching (/C-SEL) signal, the signal is not configured in the factory default Digital input configuration. Therefore, the pin number configuration of the function is performed by parameters Pn601 ~ Pn609 (0x0B).

Digital input signal	Pn000 setting		
/C-SEL (Parameter configuration)	4	5	6
ON	Analog speed mode	Position mode	Torque mode
OFF	Internal speed mode		

2. Switch except internal setting speed control (Pn000 = 7, 8, 9)

a) The Digital input signal distribution mode is internally fixed (Pn600=0).

Digital input signal	Pn000 Setting		
/C-SEL (CN1-41)	7	8	9
ON	Analog speed mode	Torque mode	Analog speed mode
OFF	Position mode	Position mode	Torque mode

b) Digital input signal distribution mode is parameter configuration (Pn600=1 default parameter).

Digital input signal	Pn000 Setting		
/C-SEL (Parameter configuration)	7	8	9
ON	Analog speed mode	Torque mode	Analog speed mode
OFF	Position mode	Position mode	Torque mode

3. Internal setting speed control switching (Pn000 = 10, 11)

a) The digital input signal distribution mode is internally fixed (Pn600=0).

Digital input signal	Pn000 setting	
/C-SEL (CN1-41)	10	11
ON	Speed mode with zero fixed function	Position mode with command pulse inhibit function
OFF	Speed mode	Position control

b) Digital signal distribution mode is parameter configuration (Pn600=1 default parameter).

Digital input signal		Pn000 Setting	
		10	11
/ZCLAMP (parameter configuration)	ON	Speed mode with zero fixed function (*1)	-
	OFF	Speed mode	-
/INHIBIT (parameter configuration)	ON	-	Position mode with command pulse inhibit function
	OFF	-	Position control

*1: The enabled method of the Digital zero-position clamp signal (/ZCLAMP) must be used in conjunction with the parameters Pn312 and Pn313. Refer to the description of the function code.

5.6 Other Output Signals

5.6.1 Servo Ready Output Signal

The servo ready output signal (/S-RDY) is a indicate signal that the servo unit can receive servo ON (/S-ON) signals and command signals.

This signal is output under the following conditions:

- The main circuit power is on. For details on the output timing of /S-RDY during power-on, see "Power-up enable ON timing".
- Non-hardwired base blocking status.
- No alarm occurred.
- When using an absolute encoder, the SEN signal turns ON (H level).

1) Parameter configuration of servo-ready

In the factory default digital output configuration, the signal is configured as CN1 25, 26 pin (Pn613=0x00) by default. Please confirm before use.

2) Wiring of servo ready

The servo ready signal is a general configurable Digital output. See "Sequence Output Circuit" for wiring details.

5.6.2 Warning Output Signal

The warning output signal (/WARN) is a warning function before the alarm, which makes it easier for the host device to judge the operation of the servo unit in advance. For detailed warning code, please refer to "Warning Code".

1) Configuration of warning output signals

This signal is not configured in the factory default Digital output configuration. The pin number

configuration (0x07 / 0x107) needs to be performed by parameters Pn613 ~ Pn615.

2) Polarity setting of warning output signals

The polarity of servo warning detection can be changed by setting the Digital output configuration as 0x07 / 0x107.

3) Wiring of warning output signal

The warning output signal is a general configurable Digital output signal. See “sequence control output circuit” for wiring details.

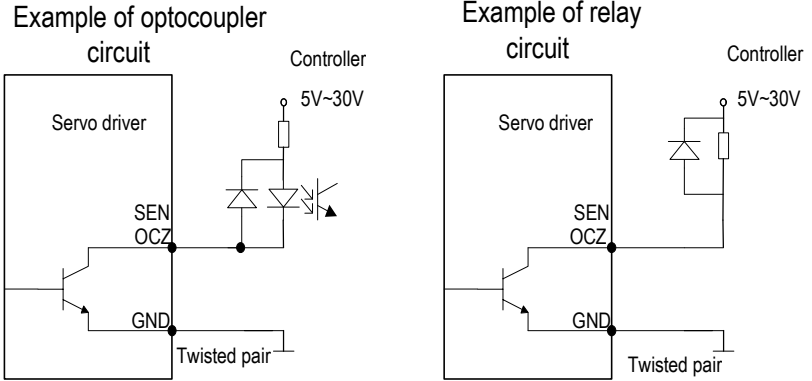

5.7 Timing Sequence

5.7.1 Power Enable ON Timing sequence

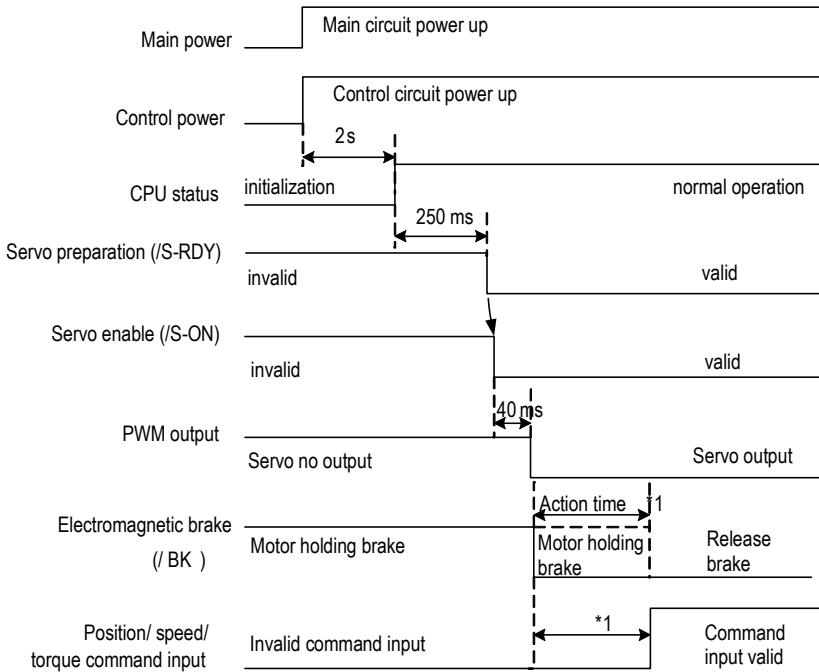

1: There is a delay in the electromagnetic brake operation. The operation time varies depending on the type of brake. It is recommended to be more than 100ms to ensure that the electromagnetic brake is completely released when the command is input. This time can be omitted when motor is not braked.

5.7.2 Power-Off Enable OFF Timing Sequence

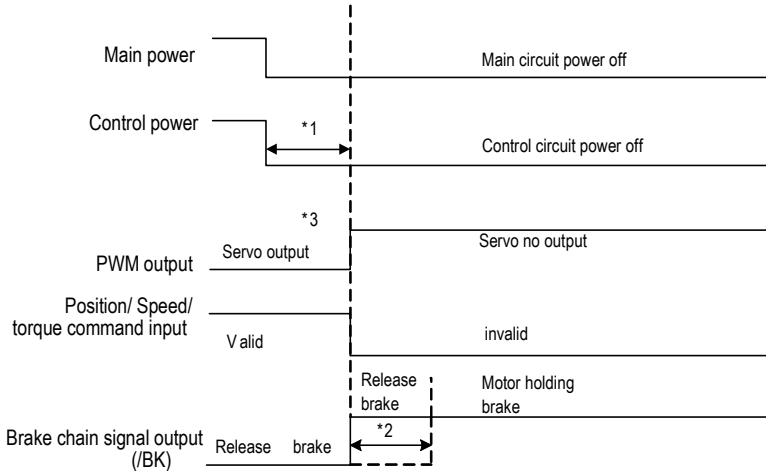

1. Undervoltage fault occurs when the control power supply voltage drops below 170V/350V (220V series, 400V series.).
2. Output from /BK to the actual brake of the motor. The time varies depending on the type of the brake. See "Electromagnetic brake" for the timing of the /BK signal when the alarm or enable is OFF.
3. For the vertical axis, when the enable is ON, the power is off, the motor brake may not be completed, and the machine may move.

5.8 Full Closed Loop Control

5.8.1 What Is a Fully Closed Loop System

The full closed-loop system is a system that uses external position feedback device (external encoder or grating ruler, etc.) to detect the actual machine position of the controlled object and feed back the actual machine position information to the servo unit. Because the actual machine position is directly fed back to the driver, high-precision positioning control can be realized.

The full closed-loop servo system can eliminate the error caused by mechanical transmission mechanism, while the semi closed-loop servo system can only compensate part of the error. Therefore, the accuracy of the semi-closed-loop servo system is lower than that of the full closed-loop system. Because of the position detection device, the position control accuracy of the closed-loop feed system mainly depends on the resolution and accuracy of the detection device (grating ruler, etc.) after other factors are determined.

The structure of the full closed-loop and semi closed-loop servo system is more complicated than

that of the open-loop feed system because of the position detection device. In addition, because the mechanical transmission mechanism is partially or completely included in the system, the natural frequency, damping and clearance of the mechanical transmission mechanism will become unstable factors of the system. Therefore, the design and debugging of the closed-loop and semi closed-loop systems are more difficult than those of the open-loop systems.

The system structure is as follows:

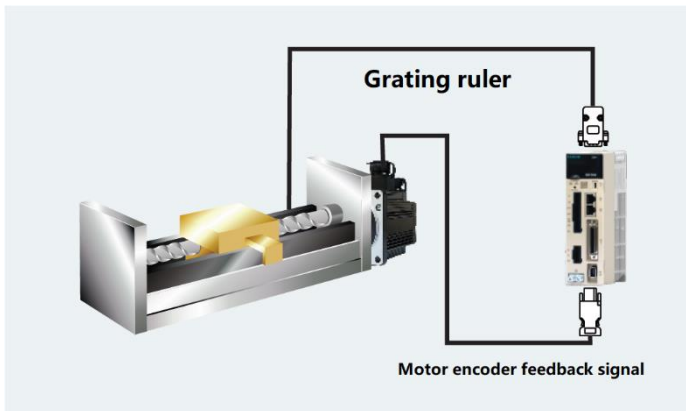

1. The gain adjusted in the semi closed loop mode may not be applicable in the full closed loop mode, so after the completion of adjustment in the semi closed loop mode switch to the fully closed loop mode need to re-optimize the gain parameters, so that the machinery and equipment to achieve good operating conditions.
2. To use the full closed loop function must first make the system in the semi closed loop mode to run normally before switching to full closed loop mode for commissioning.

5.8.2 Parameter Setting of Full Closed-Loop Control

Parameters	Setting content	Position control	Speed control	Torque control	Chapter
Pn002	Motor rotation direction selection	○	○	○	3.2
Pn250	Application of external encoder in full closed loop control	○	○	○	3.2
Pn253	Resolution of external grating ruler	○	○	○	3.3
Pn204/ Pn206	Electronic gear ratio numerator / denominator	○	—	—	3.5
Pn252	The deviation coefficient between the load of the motor with one full closed-loop rotation	○	—	—	3.6

Pn257	Setting of excessive deviation between motor and load	○	—	—	3.6
-------	---	---	---	---	-----

5.8.3 Control Block Diagram of Full Closed Loop Control

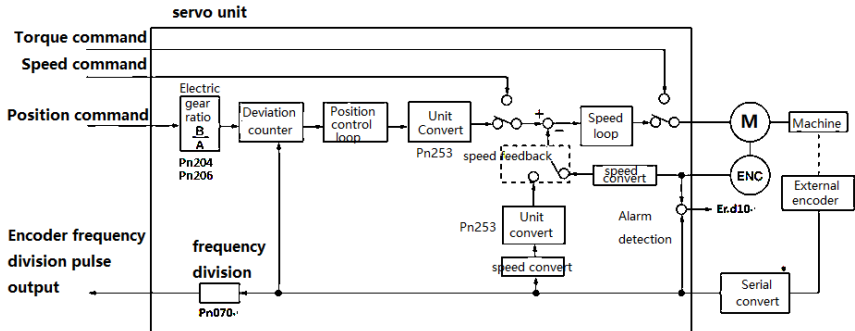

5.8.4 Setting of Motor Rotation Direction And Machine Moving Direction

When setting motor rotation direction and machine moving direction for full closed-loop control, pN002 (rotation direction selection) and PN250 (use method of external encoder in full closed-loop control) must be set at the same time.

Parameter		Pn250 Application of external encoder in full closed loop control				
		1		3		
Pn002 (Motor rotation direction)	0	Command direction	FWD command	Reverse command	FWD command	Reverse command
		Motor rotation direction	CCW	CW	CCW	CW
		External encoder	FWD move	REV move	REV move	FWD move
	1	Command direction	FWD command	Reverse command	FWD command	Reverse command
		Motor rotation direction	CW	CCW	CW	CCW
		External encoder	REV move	FWD move	FWD move	REV move

- The frequency division pulse is independent of the setting of pN002, and becomes B-phase lead for forward rotation command.
- FWD direction: the direction in which the pulse count is positive.
- REV direction: pulse counting is the direction of counting down.

Related parameters

◆ Pn002 Motor rotation direction selection

Facing the motor end face: 0 - Counter-clockwise direction is FWD, 1 - Clockwise direction is FWD.

◆ Pn250 Application of external encoder in full closed loop control

Set Pn250 = 1 or Pn250 = 3 in full closed-loop control.

Parameters		Name	Definition	Effect time	Variety
Pn250	0 (default)	Application of external encoder in full closed loop control	Not use full closed-loop control	After restart	Set
	1		Use in standard running direction		
	2		Backup		
	3		Use in reverse running direction		

Supplementary notes: please confirm the setting value of PN250 according to the following points:

- (1) Set PN250 = 1, which is used in the standard running direction.
- (2) Manually rotate the motor shaft along the CCW direction.
- (3) When the full closed-loop feedback pulse counter counts positively (Un012), or the servo monitoring parameter Un007 (feedback pulse counter) and Un012 (external encoder feedback pulse counter) change in the same direction, the setting of PN250 remains unchanged (Pn250 = 1).
- (4) When the full closed loop feedback pulse counter counts down, or if the servo monitoring parameter Un007 (feedback pulse counter) and Un012 (external encoder feedback pulse counter) change in different directions, Pn250 = 3.

5.8.5 Resolution of External Grating Ruler

Through pn253, the pitch value of the external encoder grating ruler is set by pn253, which is also called the resolution of grating ruler.

For example:

[parameters]

Pitch of grating ruler of external encoder: 0.5 μ M.

Ball screw lead: 16mm.

If the motor is not directly connected through the reduction mechanism.

Then 16mm / 0.0005mm = 32000, so the setting value is "32000".

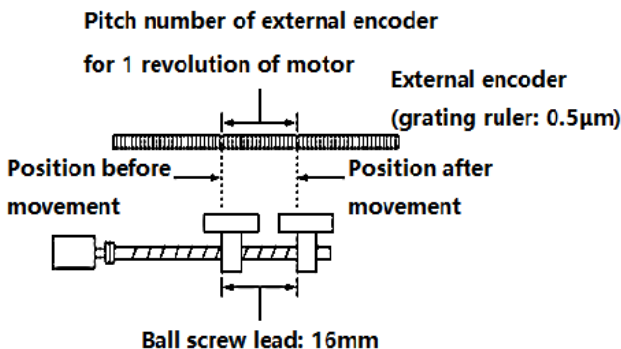

(Note)1. When the mantissa appears, please round the number after the decimal point.

2. When the pitch value of the external encoder grating ruler with motor rotation for 1 turn is not an integer, relative to the position loop gain (KP), feedforward, position command speed, monitoring as the state of containing error. But it has nothing to do with the position loop, so it will not affect the position accuracy.

Related parameter

Function code	Parameter	Range	Default	Unit	Communication address	When enabled
Pn253	Resolution of external grating ruler	4~1048576	32768	Pulse/r	0x0253	After Restart
Set the pitch value (feedback pulse number) of external grating ruler when the motor shaft rotates for 1 turn						

5.8.6 Setting of Frequency Division Pulse Output Signal of Grating Ruler / Encoder

Set the frequency division output of external position to pn070. The set value should input A, B phase edge values.

Pitch of grating ruler of external encoder: 16mm.

Ball screw lead: 16mm.

Speed: 160mm/s.

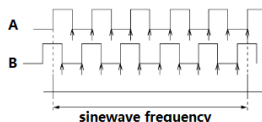

The setting value is "4000" when the output is 1 μm with 1 pulse (4 times of increasing value).

The setting value is "8000" when the output is 0.5 μm with 1 pulse (4 times of increasing value).

When the setting is "20", the output waveform of encoder frequency division pulse is shown in the "above figure".

The upper frequency limit value of encoder signal output is 4Mpps (4 times of increasing value), so

the setting value should not exceed 4Mpps. If the upper limit value is exceeded, A.511 (frequency division pulse output over speed alarm) will be output.

When setting value is "4000", and speed is 1600mm/s,

$$\frac{1600mm/s}{0.001mm} = 1600000 = 4Mpps,$$

$$1.6Mpps < 4Mpps, \text{ so it can use this setting value.}$$

5.8.7 Setting of Electronic Gear

The setting range of the electronic gear ratio is as follows:

$$0.001 \leq \text{electronic gear ratio (B/A)} \leq 16778.$$

When the setting range is exceeded, ER.040 (parameter setting abnormal alarm) will occur.

Function code	Parameter	Range	Default	Unit	Communication address	When enabled
Pn204	Electronic gear ratio (molecular)	0~1073741824	64	1	0x006/0x207	After restart
Pn206	Electronic gear ratio (denominator)	0~1073741824	1	1	0x008/0x09	After restart

Calculation method of electronic gear ratio setting value

◆Semi closed-loop control

When the machine deceleration ratio of motor shaft and load side is n / M (when the motor rotates m turns, the load shaft rotates n turns), the setting value of electronic gear ratio can be obtained as following formula.

Electric gear ratio

$$\begin{aligned} \frac{B}{A} &= \frac{Pn204}{Pn206} = \frac{\text{Number of encoder lines}}{\text{Movement of load shaft 1 revolution (Command unit)}} \times \frac{m}{n} \\ &= \frac{\text{Movement corresponded with input command 1 pulse}}{\text{Movement corresponded with grating ruler output 1 pulse}} \end{aligned}$$

Encoder resolution

The encoder resolution can be confirmed by the servo motor model. The suffix D1 or D2 is 23 bit encoder, the suffix is Q1, Q2, R1, R2 is 17 bit encoder, the suffix is E1, E2 is 24 bit encoder.

◆Full closed-loop control

Electric gear ratio

$$\frac{B}{A} = \frac{Pn204}{Pn206} = \frac{1 \text{ instruction unit movement (Command unit)} \times \text{number of segments of linear encoder}}{\text{Pitch of grating ruler for linear encoder}}$$

$$= \frac{\text{Movement corresponded with input command 1 pulse}}{\text{Movement corresponded with grating ruler output 1 pulse}}$$

Supplementary Notes

About resolution

The resolution used in the servo unit (the movement of 1 feedback pulse) can be obtained as following formula:

$$\text{Resolution (the movement of 1 feedback pulse)} = \frac{\text{the grating ruler pitch of linear encoder}}{\text{the segment number of serial conversion unit or linear encoder}}$$

The servo unit controls the servo motor in the unit of feedback pulse.

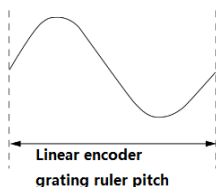

The grating ruler pitch of linear encoder = 1 cycle distance of analog voltage feedback signal sent by linear encoder.

The lead of screw rod is 16mm and the transmission ratio is 1:1 (direct connection).

Semi closed-loop mode:

Steps	Contents	Mechanical composition
		<p>Command unit: 0.0005mm</p> <p>24 bit encoder Ball screw lead:16mm</p>
1	Number of motor encoder lines	24bit encoder lines number 16777216
2	The number of pulses required for one turn of the screw rod	The command unit is 0.0005mm (0.5 μm), and the number of pulses is 32000
3	Electronic gear ratio	$\frac{B}{A} = \frac{16777216}{32000}$
4	Parameter	Pn204=16777216, Pn206=32000

Full closed-loop mode:

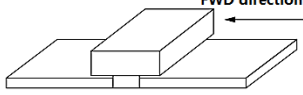
Steps	Contents	Mechanical composition
		 <p>command unit: 0.0005mm (0.5μm)</p>
1	Grating resolution of linear encoder	0.0005mm (0.5 μ m)
2	Command unit	0.0005mm (0.5 μ m)
3	Electronic gear ratio	$\frac{B}{A} = \frac{0.5}{0.5} = \frac{1}{1}$
4	Parameter	Pn204=1, Pn206=1

5.8.8 Setting of alarm detection

The alarm detection settings (Pn252, Pn257) are shown below.

The setting of detection value excessive deviation between motor and load position (pn257) is the difference between motor encoder feedback (position) and full closed-loop external encoder feedback (load position). If the set value is exceeded, output=Er.d10 (alarm of excessive deviation between motor and load position).

Pn257	Detection value of excessive deviation between motor and load position (Position mode).				
	Setting range	Setting unit	Default	Effective time	Variety
	0 ~ 1073741824	1 Command unit	1000	Immediately	Setting

(Note) when set to "0", Er.d 10 is not output.

Setting of deviation coefficient (Pn252) between motor loads when full closed-loop rotation 1 turn.

Set the "coefficient of deviation between motor and external encoder" when the motor rotates for 1 turn. It can be used to prevent out of control caused by damage of external encoder, or to detect "sliding" in belt mechanism.

◆Setting Case

When the sliding rate of the belt is large or seriously twisted, please increase the value.

If the setting value is "0", the value of the external encoder is read directly.

When the factory setting value is "20", the second turn starts from the deviation after 1 revolution of the motor multiplied by 0.8.

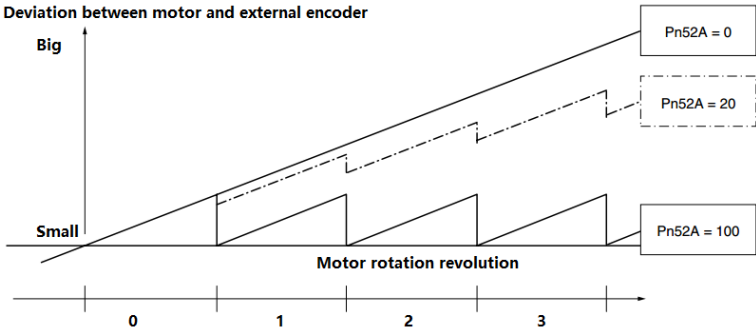

◆Related parameter

Pn252	Deviation coefficient between motor and external encoder for one full closed-loop rotation (Position mode)				
	Setting range	Setting unit	Default	Effective time	Variety
	0 ~ 100	1%	20	Immediately	Setting

6 Adjustment

6.1 Adjustments

6.1.1 Adjustments Steps

Adjustments refer to optimize the function of responsiveness by adjusting the servo unit's servo gain. Servo gain is set by the combinations of many parameters, including speed circle gain, position circle gain, filter, friction compensation, rotation inertia and so on. These parameters would influence with each other, so you must take the balance among all parameters into the consideration while setting. The factory settings of the servo gain are stable settings. Use all the adjusting functions according to the uses' mechanical conditions in order to improve the responsiveness.

The following figure is basic adjustment procedure flow chart; please adjust the machine according to the status and operating conditions of the machine.

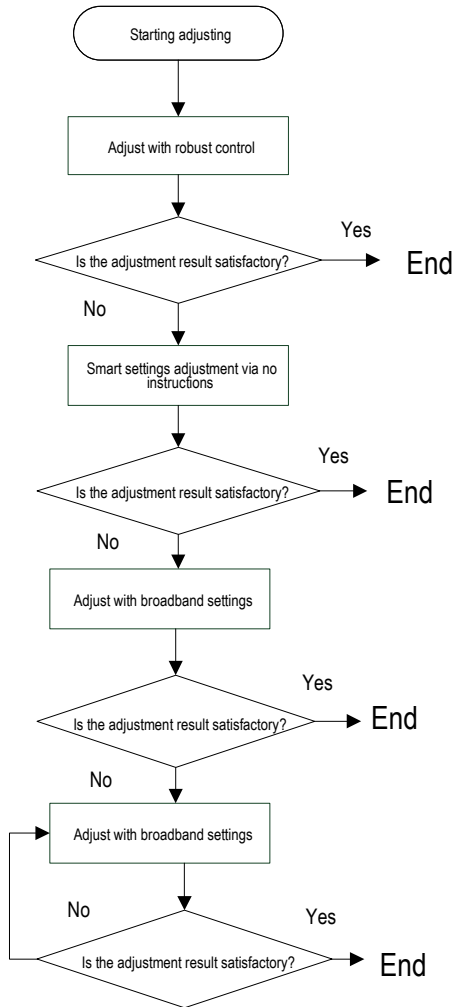

6.1.2 Safety Precautions When Adjusting

When you are making adjustments, please set the servopack protection functions shown below under appropriate conditions.

- 1) Set the overtravel

Please set the overtravel and you could refer to the servo enable and overtravel setting if you want more details.

2) The settings of the torque limit

The torque limit function is about calculate the torque that mechanical motions need in order to make sure that the torque is not greater than this torque limit value. If the torque is set below the value required for operation, overshoot or vibration may occur.

See more details in the “torque limit”.

3) Set excessive position deviation alarm value

The excessive position deviation alarm is an effective protection function when we are using servo unit for position control.

When the motor operation does not match the command, you can detect the abnormal condition and stop the motor by setting an appropriate position deviation alarm.

The position deviation is the difference between the position command value and the actual position.

The position deviation can be expressed by the relationship between the following position loop gain (Pn103) and motor speed.

$$\text{Position deviation command unit} = \frac{\text{Motor speed}[\text{min}^{-1}]}{60} * \frac{\text{Encoder resolution}^{\ast 1}}{\text{Pn103}[0.1/\text{s}]/10^2} * \frac{\text{Pn206}}{\text{Pn204}}$$

When the acceleration/deceleration of the position command exceeds the tracking ability of the motor, the follow-up hysteresis will become large, resulting in the positional deviation not satisfying the above relation. Please reduce the acceleration and deceleration of the position command to the value that can be tracked by the motor or increase the value of the excessive position error alarm.

4) Set the vibration detection function

Please initialize (Fn105) the detection value detected by the vibration and set an appropriate value for the vibration detection function. For details, refer to the corresponding “Accessibility”.

5) Set excessive position deviation alarm value when servo is ON

If the servo is turned ON while the position deviation is accumulated, the motor will return to the original position to make the position deviation “0” and avoid causing a danger. In order to avoid this kind of situation, you can set an excessive position deviation alarm value when the servo is turned on to restrict the operation.

6.2 Robust Control

In factory default, the robust control function is valid. When resonance and vibration occur, please change the attune value and load value via Fn301 or set Pn177 and Pn178.

6.2.1 Summary

Robust function could get stable response through adjusting the whole system automatically no matter what kind of mechanism or fluctuation of load.

Function	Parameter	Range	Default	Unit	Communication	When
----------	-----------	-------	---------	------	---------------	------

code					address	enabled
Pn175	Robust control selection	0x00 ~ 0x01	1	—	0x0175	After restart
	Set the robust control function switch: 0-invalid 1-valid					
Pn177	Robust control tuning value	10 ~ 80	40.0	Hz	0x0177	Immediately
	Set a greater robust control gain tuning value, systematic response gets faster, but system overshoot and excessive noise may occur.					
Pn178	The minimum value of robust control	0 ~ 500	0	%	0x0178	Immediately
	Set a greater load ratio of robust control, systematic response gets faster, but the systematic excessive noise may occur, and we could increase this value in order to decrease the over-adjustment and overshoot when torque is excessive.					

Robust control function is valid in position control or speed control and invalid in torque control. When robust control is valid, some of the control functions of below table would be restrained.

Function name	Operation	Executable conditions and notes
Vibration detection value initialization (Fn105)	Yes	Robust control is invalid in operation, and it turns to be valid when the operation is over.
Bandwidth setting (Fn303)	No	
EasyFFT (Fn401)	Yes	Robust control is invalid in operation, and it turns to be valid when the operation is over.
Gain shift	No	
Inertia recognition	Yes	Robust control is invalid in operation, and it turns to be valid when the operation is over.
Mechanical analysis	Yes	Robust control is invalid in operation, and it turns to be valid when the operation is over.

Which parameters become invalid when robust control function are valid.

When we set robust control function valid in factory default, the Pn100, Pn101, Pn102, Pn103, Pn105, Pn106, Pn107, Pn140, Pn110, Pn170 are invalid.

6.2.2 Operating Procedure

Robust control function could be set via the auxiliary function Fn301 on panel operator and more details on “Auxiliary function”, or we could set relevant parameters via “parameters setting”.



Before operating the robust control function, please confirm the setting below, if not, it will display /NO- OP in operation:

1. Robust control function is valid (Pn175=1).
2. No motor debugging function is invalid (Pn730=0).

6.2.3 Additional Notes

In robust control, due to the increase of the tuning value, the system may cause resonance noise. It can choose whether automatic setting by Pn151 (Notch filter 2 automatic adjustment selection). The factory default is "Auto-tuning". Only when the corresponding notch function is not needed, it is set to "Auto-adjust without auxiliary function".

Function code	Parameter	Range	Default	Unit	Communication address	When enabled
Pn151	Notch filter 2 automatic adjustment selection	0x00 ~ 0x01	1	—	0x0151	Immediately
	0-No automatic adjustment via auxiliary functions. 1-Automatic adjustment via auxiliary functions.					

6.2.4 Related Parameters

The parameters need to be set are shown as below when operating robust control function:

Parameter	Name
Pn175	Robust switch
Pn104	First torque command filter
Pn156	Second notch filter frequency
Pn157	Second notch filter Q value

6.3 Inertia Identification

6.3.1 Summary

“Inertia identification” means that the servo unit performs automatic operation (forward and reverse reciprocating motion) without issuing commands from the host device, and the load rotary inertia is recognized during operation.

The rotary inertia ratio (ratio of load rotary inertia to motor rotor inertia) is the reference parameter for performing the gain adjustment, and the correct value must be set.

The load rotary inertia can be calculated based on the weight and composition of each part of the mechanism, but the operation is very complex. With this function, after the motor is driven several times in the positive/negative direction, a high-precision load rotary inertia can be obtained.

The motor operates according to the following operating specifications.

- Maximum speed: $\pm 1000\text{min}^{-1}$ (changeable)
- Acceleration: $\pm 20000\text{min}^{-1}/\text{s}$ (changeable)
- Travel distance: Maximum ± 2.5 turns (changeable)

6.3.2 Steps

The inertia recognition function can only be identified by the PC debugging software “VCSDsoft”. Inertia identification steps refer to “Host device debugging related”- “Inertia identification”.

6.3.3 Additional Notes

- When identifying the inertia, please make sure that the system can operate the range and set the operating conditions reasonably according to the operable range. Under different operating conditions, the recognition result may have minor deviations.
- If the servo torque limit is set too small, the result of inertia identification may be affected, resulting in discrepancy between the identification result and the actual inertia. Please confirm before identification.
- After inertia identification, after changing the inertia ratio (Pn100), the original gain-related parameters of the servo system need to be re-adjusted, otherwise vibration and noise may occur.
- Write operation is required after inertia identification, otherwise the inertia identification result is invalid.

6.4 Intelligent Setting

6.4.1 Summary

Users can choose intelligent setting with command input and no command input:

- 1) No command input (When there is no pulse from the controller)

It means the function of automatically adjusting the servo unit according to the mechanical characteristics when the automatic operation (forward and reverse reciprocating motions) is performed within the set range. Intelligent settings can be performed without connection to the control system.

The automatic operation is as follows:

- Highest speed: motor rated speed
 - Acceleration torque: motor rated torque about 100%
 - Move distance: can be set arbitrarily. The factory setting is equivalent to 3 turns of the motor
- 2) Command input (When a controller sends pulses)

It is the method of automatically adjusting the running command from the host control system.

The command intelligent setting can also be used for additional adjustments after the no-command intelligent setting. When the correct inertia ratio is set, no-command intelligent setting can be omitted, and only the intelligent setting operation with Commands is performed.



The command smart setting starts with the present speed loop gain (Pn101) as a reference. If vibration occurs at the start of the adjustment, correct adjustment cannot be performed. In this case, pls decrease the speed loop gain (Pn101) until the vibration disappears, and then readjust.

The intelligent setting process adjusts the following items:

- Rotary inertia ratio (No command intelligent setting)
- Gain adjustment (speed loop gain, position loop gain, etc.)
- Filter adjustment (torque command filter, notch filter)
- Friction compensation
- IF suppression control (intermediate frequency)
- Vibration suppression
- Low-frequency vibration suppression (only when Mode = 2 or 3) (No command intelligent setting)

6.4.2 Steps

The intelligent setting function cannot be set by the panel keyboard, and it needs to cooperate with the PC debugging software to perform related operations. No command intelligent setting is slightly different from the related operation of the command intelligent setting. For detailed steps, see "host computer operation instructions" - "Intelligent setting".

1) Confirmation before execution

Before perform intelligent settings, be sure to confirm the following settings. If set incorrectly, this function cannot be performed during operation.

- No overtravel has occurred
- Not torque control
- Gain switching selection switch is manual gain switching (Pn110 = 0) and is the first gain
- No motor test function is invalid (Pn730 = 0)
- No alarm or warning occurred
- Robust control function is invalid (Pn175 = 0)



1. When executing intelligent setting without command in speed control state, it will automatically switch to position control to execute adjustment, and return to speed control after adjustment.
2. The intelligent setting with command cannot be executed in the torque control state.
3. In the process of intelligent setting, the command pulse input multiplier switching function will become invalid.

2) Failed to perform adjustment or adjustment failed example

In the following occasions, intelligent settings will not be performed properly. Please use the bandwidth setting (see "Bandwidth setting" for details):

- The motor is power ON (servo ON) in position control (with command intelligent setting)
- When the mechanical system can only run in one direction
- The scope of activities is narrow, below 0.5 round
- When the rotary inertia changes within the set operating range
- When the mechanical dynamic friction is large
- The mechanical rigidity is low and vibration occurs during positioning
- When P (proportional) control is selected, "Load inertia moment measurement" is selected, In the process of rotary inertial identification, or when switching to P control through P/CON signal
- When using the mode switch, when "Load moment of inertia measurement" is selected, the mode switch function becomes invalid during the moment of inertia identification and becomes PI control. The mode switch function becomes valid again after the rotary

inertia identification is completed

- When speed feed forward and torque feed forward are input
- When the positioning complete width (Pn262) is small

	<p>1. When there is no command for intelligent setting, please change the adjustment mode and adjust with bandwidth setting or robust control when the adjustment fails for variable inertia load.</p> <p>2. For intelligent setting, please set "Electronic gear ratio (Pn204/Pn206)" and "Positioning completion range (Pn262)" are set to the actual operating values. Otherwise, the adjustment may fail or the adjustment result may not match the actual operation result.</p>
---	--

6.4.3 Additional Notes

1) Vibration suppression function

Before the intelligent setting, you can set whether the related vibration suppression function is automatically set. The factory default is automatically set, please set the corresponding function switch to "Do not adjust automatically" before you want to change the value of the intelligent setting.

Function code	Parameter	Range	Default	Unit	Communication address	When enabled
Pn140	IF suppression control options	0x00 ~ 0x11	0x0010	—	0x0140	Immediately
	<p>The IF (intermediate frequency) suppression control function can effectively suppress the continuous vibration of about 100Hz ~ 1000 Hz that occurs when the control gain is increased.</p> <p>0x1#: Automatically set IF vibration suppression frequency through intelligent setting and bandwidth setting.</p> <p>0x0#: Not set automatically through intelligent setting and bandwidth setting, only manual setting.</p> <p>0x#1: IF suppression frequency setting is valid.</p> <p>0x#0: IF suppression frequency setting is invalid.</p>					
Pn150	Notch filter 1 automatic adjustment selection	0x00 ~ 0x01	1	—	0x0150	Immediately
	<p>0- Automatic adjustment without auxiliary functions.</p> <p>1- Automatic adjustment through auxiliary functions.</p>					
Pn151	Notch filter 2 automatic adjustment selection	0x00 ~ 0x01	1	—	0x0151	Immediately
	<p>0- Automatic adjustment without auxiliary functions.</p> <p>1- Automatic adjustment through auxiliary functions.</p>					

Pn231	Low frequency vibration suppression function automatic adjustment selection	0x00 ~ 0x01	1	—	0x0231	Immediately
	<p>This parameter is set to select whether low-frequency vibration suppression is automatically set under the auxiliary functions such as intelligent setting and bandwidth setting:</p> <p>0 - Vibration suppression function is not automatically adjusted by auxiliary functions.</p> <p>1- Vibration suppression function is automatically adjusted by auxiliary functions.</p>					

2) Feed forward function

In the factory setting mode, when the tuning mode is executed by “2”, “3”, “feedforward command (Pn109)”, “speed feedforward (VREF) input”, and “torque feedforward (T-REF) input” will become invalid.

According to the system configuration, if you want to use “Speed feedback (V-REF) input”, “Torque feedforward (T-REF) input” and model tracking control from the upper device at the same time, set Pn249 = 1.



When using model tracking control with this function, the model tracking control sets the optimal feedforward inside the servo. Therefore, the "velocity feedforward (V- REF) input" and "torque feedforward (T- REF) input" from the upper unit are usually not used simultaneously. If the input feedforward is incorrect, it may cause overshoot, but please note that it can be used as necessary.

6.4.4 Related Parameters

The parameters that may be changed when executing the intelligent setting function are as follows:

Parameter	Name
Pn100	Rotary inertia ratio
Pn101	First speed gain
Pn102	First speed integral time constant
Pn103	First position gain
Pn104	First torque command filter
Pn140	Intermediate frequency (IF) vibration suppression control selection
Pn141	IFvibration suppression inertia modification
Pn142	IF suppression frequency
Pn143	IF suppressionattenuation gain

Pn153	Notch filter 1 frequency
Pn154	Notch filter 1 Q value
Pn155	Notch filter 1 depth
Pn156	Notch filter 2 frequency
Pn157	Notch Filter 2 Q Value
Pn158	Notch filter 2 depth
Pn240	Model tracking control selection
Pn241	Model tracking control gain
Pn242	Model tracking control attenuation coefficient
Pn243	Model tracking control speed feed forward gain
Pn244	Model tracking control forward torque feed forward gain
Pn245	Model tracking control reverse torque feed forward gain

6.5 Bandwidth Setting

6.5.1 Profile

The bandwidth setting is a method of inputting a speed command or a position command from the host device, and manually adjusting the running speed.

By adjusting one or two values with the bandwidth setting, the relevant servo gain setting can be automatically adjusted.

The bandwidth setting adjusts the following items:

- Gain adjustment (speed loop gain, position loop gain, etc.)
- Filter adjustment (torque command filter, notch filter)
- Friction compensation
- IF (intermediate frequency) suppression control
- Low frequency vibration suppression
- Use the bandwidth setting when you cannot achieve satisfactory response characteristics after setting it by intelligent settings. If you want to further fine-tune each servo gain after adjusting the bandwidth setting, see “Manual Adjustment Function” for manual tuning

6.5.2 Steps

Before performing bandwidth setting, be sure to confirm the following settings. If it is set incorrectly, “NO-OP” will be displayed in the operation and this function cannot be performed.

- Invalid selection of no motor test function (Pn730 = 0)

- Robust control selection is invalid (Pn175 = 0)
- Tuning mode is set to 0 or 1 when tuning is performed by speed control

The bandwidth setting procedure can be performed by any one of the SERVO Keyboard or PC debugging software. However, the keyboard can only operate when the tuning mode is set to “0-stability” or “1-high response”. For detailed operation procedure, see “7.13 Bandwidth Setting (Fn303)”. When positioning-specific adjustments “2-positioning” and “3-positioning without overshoot” are required, it shall be used with “PC debugging software”.



Please set the bandwidth after the inertia recognition or the intelligent setting of the rotation inertia ratio (Pn100) correctly.

6.5.3 Additional Notes

(1) Vibration suppression function

Before setting the bandwidth, confirm whether the related vibration suppression function is automatically setting. The factory default is automatically setting. Please set the corresponding function switch to “No adjust automatically” before you don’t want to change its value through the bandwidth setting.

Function code	Parameter	Range	Default	Unit	Communication address	When enabled
Pn140	IF suppression control options	0x00 ~ 0x11	0x0010	—	0x0140	Immediately
	<p>The IF(intermediate frequency) suppression control function effectively suppresses the continuous vibration of about 100 to 1000 Hz that occurs when the control gain is increased.</p> <p>0x1#: Automatically set IF vibration suppression frequency through intelligent setting and bandwidth setting.</p> <p>0x0#: Not set automatically through intelligent setting and bandwidth setting, only manual setting.</p> <p>0x#1: IF suppression frequency setting valid.</p> <p>0x#0: IF suppression frequency setting invalid.</p>					
Pn150	Notch filter 1 automatic adjustment selection	0x00 ~ 0x01	1	—	0x0150	Immediately
	<p>0- Automatic adjustment without auxiliary functions.</p> <p>1- Automatic adjustment through auxiliary functions.</p>					
Pn151	Notch filter 2 automatic adjustment selection	0x00 ~ 0x01	1	—	0x0151	Immediately

	0- Automatic adjustment without auxiliary functions. 1- Automatic adjustment through auxiliary functions.					
Pn231	Low frequency vibration suppression function automatic adjustment selection	0x00 ~ 0x01	1	—	0x0231	Immediately
	This parameter is set in the intelligent settings, bandwidth settings and other auxiliary functions under low-frequency vibration suppression is automatically set to choose: 0 - Vibration suppression function is not automatically adjusted by auxiliary functions. 1 - Vibration suppression function is automatically adjusted by auxiliary functions.					

(2) Feed forward function

In the factory setting mode, when excute tuning mode by “2” & “3”, “feedforward command (Pn109)”, “speed feedforward (VREF) input”, and “torque feedforward (T-REF) input” will be invalid.

According to the system configuration, if you want to use “V-REF input”, “Torque feed forward (T-REF) input”, and model tracking control from the host device at the same time, set Pn249 = 1.



When using model tracking control with this function, the model tracking control sets the optimal feedforward inside the servo. Therefore, the “velocity feedforward (V- REF) input” and “torque feedforward (T- REF) input” from the upper unit are usually not used simultaneously. If the input feedforward is incorrect, it may cause overshoot, but please note that it can be used as necessary.

6.5.4 Related Parameters

The relevant parameters and parameters that are automatically set when executing the bandwidth setting function are as follows:

Parameter	Name
Pn100	Rotary inertia ratio
Pn101	First speed gain
Pn102	First speed integral time constant
Pn103	First position gain
Pn104	First torque command filter
Pn140	IF vibration suppression control selection
Pn141	IF vibration suppression inertia modification
Pn142	IF suppression frequency
Pn143	IF suppression attenuation gain
Pn153	Notch filter 1 frequency

Pn154	Notch filter 1 Q value
Pn155	Notch filter 1 depth
Pn156	Notch filter 2 frequency
Pn157	Notch Filter 2 Q Value
Pn158	Notch filter 2 depth
Pn240	Model tracking control selection
Pn241	Model tracking control gain
Pn242	Model tracking control attenuation coefficient
Pn243	Model tracking control speed feed forward gain
Pn244	Model tracking control forward torque feed forward gain
Pn245	Model tracking control reverse torque feed forward gain

6.6 Manual Adjustment Function

This function is needed for further individual adjustment requirement after the adjustment of intelligent setting and bandwidth setting.

6.6.1 Servo Gain

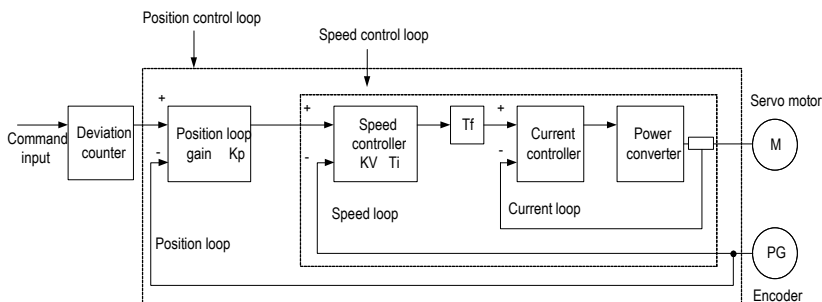

Please adjust each servo gain one by one after fully understanding the composition and characteristics of the servo units if the servo gain needs to be adjusted manually. In most cases, if one parameter changes significantly, the other parameters must be adjusted again. In order to confirm the response characteristics, preparations must be made to observe the output waveform of the analog monitor using a measuring instrument.

The servo unit consists of three feedback loops (position loop, speed loop, and current loop). The outermost is the position loop and the innermost is the current loop. The more the inner loop, the more it needs to improve the responsiveness. Failure to follow this principle will result in poor responsiveness or vibration.

Since the current loop ensures sufficient responsiveness, the user does not have to make adjustments.

The response characteristics of the servo unit can be adjusted by setting the following servo gains.

Function code	Parameter	Range	Default	Unit	Communication address	When enabled
Pn100	Moment of inertia ratio	0 ~ 20000	100	%	0x0100	Immediately
	Moment of inertia ratio = load moment of inertia converted by motor shaft / rotor moment of inertia of servo motor *100%.					
Pn101	First speed gain	1 ~ 2000	40.0	Hz	0x0101	Immediately
	Determine the parameters of the speed loop responsiveness. If the response of the speed loop is low, it will become a delay factor of the outer position loop, and overshoot or vibration of the speed command occurs. In the range where the mechanical system does not vibrate, the larger the setting, the more stable the servo system, and the better the responsiveness.					
Pn102	First speed integration time constant	0.15 ~ 512	20.00	ms	0x0102	Immediately
	In order to respond to small inputs, the speed loop contains integral elements. Since the integral element is a delay element for the servo system, when the time parameter is set too large, overshoot may occur, or the positioning time may be prolonged, resulting in poor response.					
Pn103	First position gain	1 ~ 2000	40.0	1/s	0x0103	Immediately
	The position loop response is determined by the position loop gain. The higher the setting of the position loop gain, the higher the responsiveness and the shorter the positioning time. The position loop gain cannot be increased beyond the rigidity of the mechanical system. To increase the position loop gain to a larger value, the rigidity of the machine must be increased.					
Pn104	First torque command filter	0 ~ 655.35	1.00	ms	0x0104	Immediately
	Adjusting the parameters of the torque command filter may eliminate the machine vibration caused by the servo drive. The smaller the value, the better the responsiveness can be controlled. However, the conditions are restricted by the machine conditions.					
Pn401	Torque command second-order low-pass filter cut-off frequency	100 ~ 5000	5000	Hz	0x0401	Immediately
	Use this parameter to set the cutoff frequency of the second-order torque filter. When this parameter is set to 5000, the function of the filter is invalid.					
Pn402	Torque command second-order low-pass filter Q value	0.5 ~ 1	0.50	1	0x0402	Immediately
	Use this parameter to set the Q value of the second-order torque filter. Increasing the Q value can improve the system responsiveness, but noise will be generated when the setting is too large.					

6.6.2 Gain Switching

The gain switching function includes “manual gain switching” that uses an external input signal and “automatic gain switching” that automatically switches.

By using the gain switching function, it could increase the gain and shorten the positioning time during positioning, and it could reduce the gain and suppress the vibration when the motor stops.

Function code	Parameter	Range	Default	Unit	Communication address	When enabled
Pn110	Gain switching mode selection switch	0x00 ~ 0x01	0	-	0x0110	Immediately
	<p>The gain switching function includes two methods of “manual gain switching” using an external input signal and “automatic gain switching” that automatically switches. By using the gain switching function, it could increase the gain and shorten the positioning time during positioning, and it could reduce the gain and suppress the vibration when the motor stops.</p> <p>0-Manual gain switching by external input signal of manual gain switching (G-SEL). 1-When the automatic switching condition is met (Pn111), it automatically switches from the first gain to the second gain; Otherwise, it switches back to the first gain.</p>					
Pn111	Position control gain automatic switching condition	0x00 ~ 0x05	0	-	0x0111	Immediately
	<p>Set the conditions for automatic gain switching: 0-positioning completion signal ON. 1-positioning completion signal OFF. 2-positioning proximity signal ON. 3-positioning proximity signal OFF. 4-position command is 0 after filter and pulse input is OFF. 5-position command pulse input ON. If the condition is met, it will switch to the second gain, otherwise it switches back to the first gain.</p>					
Pn112	Gain switching transition time 1	0 ~ 65535	0	ms	0x0112	Immediately
	<p>After waiting for the waiting time from the time when the switching condition has been met, the first position loop gain is linearly changed to the second position loop gain during the switching transition time.</p>					
Pn113	Gain switching transition time 2	0 ~ 65535	0	ms	0x0113	Immediately
	<p>After waiting for the waiting time from the time when the switching condition has been met, the second position loop gain is linearly changed to the first position loop gain during the switching transition time.</p>					
Pn114	Gain switching wait time 1	0 ~ 65535	0	ms	0x0114	Immediately

	The waiting time from when the switching condition of the first gain to the second gain is met to the time when the switching actually starts.					
Pn115	Gain switching wait time 2	0 ~ 65535	0	ms	0x0115	Immediately
	The waiting time from when the switching condition of the second gain to the first gain is met to the time when the switching actually starts.					

Switching gain combination

Switching gain	Speed loop gain	Speed loop integration time constant	Position loop gain	Torque command filter	Model tracking control	Model tracking control gain correction
First gain	First speed loop gain (Pn101)	First speed loop integration time constant (Pn102)	First position loop gain (Pn103)	First torque command filter (Pn104)	First model tracking control gain (Pn241)	First model tracking control gain attenuation coefficient (Pn242)
Second gain	Second speed loop gain (Pn105)	Second speed loop integration time constant (Pn106)	Second position loop gain (Pn107)	Second torque command filter (Pn108)	Second model tracking control gain (Pn246)	Second model tracking control gain attenuation coefficient (Pn247)



1. The gain switching of model tracking control gain and model tracking control attenuation coefficient is only applicable to "manual gain switching".
2. The gain switching of model tracking control gain and model tracking control attenuation coefficient can only be switched when the following conditions are met.
 - No command.
 - Motor is stopped.

(1) Manually switch

"Manual switching gain" means the first gain and the second gain are switched by the external input signal "gain switching signal (/G-SEL)".

a) Gain switching configuration

The signal is not configured in the factory default digital configuration. Therefore, the pin number configuration (0x0E) needs to be configured by parameters Pn601 ~ Pn609.

b) Gain switching wiring

The gain switching signal is a general configurable digital input. See "Sequence Input Circuit" for wiring details.

(2) Automatic switching

Function code	Parameter	Range	Default	Unit	Communication address	When enabled
Pn111	Position control gain automatic switching condition	0x00 ~ 0x05	0	-	0x0111	Immediately
	Set the conditions for automatic gain switching: 0-Position completion signal ON. 1-Position completion signal OFF. 2-positioning proximity signal ON. 3-positioning proximity signal OFF. 4-position command filtered to 0 and pulse input OFF. 5-position command pulse input ON. If the condition is met, switch to the 2nd gain, otherwise switch to the 1st gain.					

“Auto switching gain” is only valid in position control. The switching conditions are performed by the following settings:

Switching logic

Parameter	Switching conditions	Switching gain	Switching waiting time	Switching time
Pn111 setting corresponding condition A	Condition A is met	The first gain → Second gain	Waiting time 1 Pn114	Switching time 1 Pn112
	Condition A isn't met	The second gain → First gain	Waiting time 2 Pn115	Switching time 2 Pn113

For example, in the automatic switching gain mode conditioned on the completion of the positioning signal (/COIN), it is assumed that the position loop gain Pn103 is switched to the second position loop gain Pn107. The /COIN signal of the switching condition is ON, and after waiting for the waiting time Pn114 from the time when the switching condition has been met, the gain is linearly changed from Pn103 to Pn107 during the switching time Pn112.

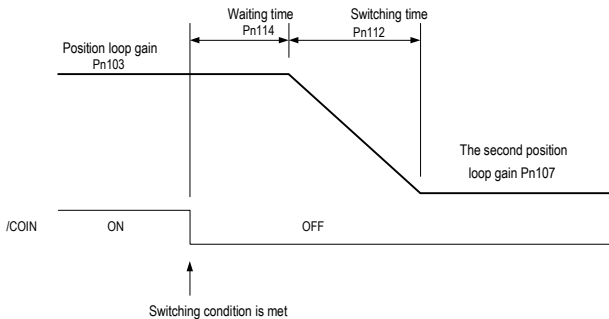

6.6.3 Speed Feedforward

Feedforward is the function of feedforward compensation to shorten the positioning time during position control.

The speed feedforward is divided into internal speed feed forward (Pn121/Pn122) and analog (V-REF) given speed feedforward (using V-REF as speed feedforward selection Pn123). This command is sent to the servo unit together with the position command.

Related parameters

Function code	Parameter	Range	Default	Unit	Communication address	When enabled
Pn121	Speed feedforward gain	0 ~ 100	0	%	0x0121	Immediately
	Speed feedforward is a function to shorten the positioning time. This function is effective when the servo unit performs position control. Note: When the feedforward command is too large, position overshooting will occur. Please check the response and set appropriately.					
Pn122	Speed feedforward filter time	0 ~ 64	0.00	ms	0x0122	Immediately
	Speed feedforward low-pass filter time constant, which can slow position overshoot and torque jump caused by feedforward.					
Pn123	Use V-REF as speed feedforward selection	0x00 ~ 0x01	0	-	0x0123	After restart
	Speed feedforward is a function to shorten the positioning time. It is possible to select speed feedforward given via external analog V-REF. 0-None. 1-Use V-REF as speed feedforward input.					
Pn300	Analog speed command gain	150 ~ 3000	600	0.01V/ rated speed	0x0300	Immediately
	Use this parameter to set the analog voltage value of (V-REF) required by speed command that makes the servo motor speed as rated value. Note: Do not apply a voltage over-10V ~ 10V. Exceeding this range may damage the servo drive.					

6.6.4 Torque Feedforward

Torque feedforward is a function to shorten the positioning time. The command is generated by deviating the position command on the host device side. This command is sent to the servo together with the speed command.

The speed command from the host device is connected to V-REF (CN1-5, 6), and the torque

feedforward command is connected to T-REF (CN1-9, 10).

Related parameters

Function code	Parameter	Range	Default	Unit	Communication address	When enabled
Pn124	Speed/position control selection (T-REF assignment)	0 ~ 1	0	-	0x0124	After restart
	Torque feedforward is a function to shorten the positioning time. Torque feedforward can be selected to given by external analog T-REF. 0-None. 1-T-REF as a torque feedforward input.					
Pn405	Analog torque command gain	10 ~ 100	30	0.1V/ Rated torque	0x0405	Immediately
	Use this parameter to set the analog voltage value of (T-REF) required by servo motor rated torque. Note: Do not apply a voltage over -10V ~ 10V. Exceeding this range may damage the servo drive.					

6.6.5 PI-P Switching

When the control mode is speed control or position control, it could switch to PI-P control. When the control mode is mixed, it is valid only when it is switched to internal speed, analog speed and position mode. The PI-P switching can be switched by the digital signal “manual PI-P control signal (/P-CON)”. When the /P-CON signal is ON, P control is performed. The conditions for selecting automatic switching can also be selected by the parameter speed loop PI-P switching condition selection switch Pn131.

(1) Manual PI-P Control

a) Configuration of manual PI-P Control

The signal is not configured in the factory default digital configuration. Therefore, the pin number configuration (0x05) needs to be performed by parameters Pn601 ~ Pn609.

b) The wiring of manual PI-P control

The gain switching signal is a general configurable digital input. See “Sequence Input Circuit” for wiring details.

(2) Automatic switching

The switching condition of automatic PI-P switching is set by Pn131, and the switching condition value is set by Pn132, Pn133, Pn134, and Pn135. By properly setting the switching conditions and condition values, overshoot during acceleration and deceleration can be suppressed and the settling time can be shortened.

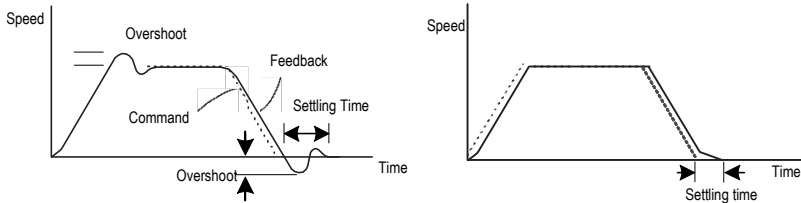

Function code	Parameter	Range	Default	Unit	Communication address	When enabled
Pn131	Speed loop PI-P switching condition selection switch	0x00 ~ 0x04	0	-	0x0131	Immediately
	<p>The mode switch is a function that automatically performs P control and PI control switching. Setting the switching condition by this parameter and satisfying the corresponding switching condition value can suppress overshoot during acceleration and deceleration and shorten the settling time.</p> <p>0 - Conditioned by internal torque command. 1 - Conditioned by speed command. 2 - Conditioned by acceleration. 3 - Conditioned by position deviation pulse. 4 - No mode switch function.</p>					
Pn132	Speed loop PI-P switching condition (torque command)	0 ~ 800	200	%	0x0132	Immediately
	<p>When the torque command exceeds the torque set by this parameter, the speed loop will be switched to P control, otherwise to PI control.</p>					
Pn133	Speed loop PI-P switching condition (speed command)	0 ~ 10000	0	rpm	0x0133	Immediately
	<p>When the speed command exceeds the speed set by this parameter, the speed loop will be switched to P control, otherwise to PI control.</p>					
Pn134	Speed loop PI-P switching conditions (acceleration)	0 ~ 30000	0	rpm/s	0x0134	Immediately
	<p>When the speed command exceeds the acceleration set by this parameter, the speed loop will be switched to P control, otherwise to PI control.</p>					
Pn135	Speed loop PI-P switching conditions (position deviation)	0 ~ 10000	0	command unit	0x0135	Immediately
	<p>When the position deviation exceeds the value set by this parameter, the speed loop will be switched to P control, otherwise to PI control.</p>					

When the switching condition of the mode switch is set as torque command [factory default], if the torque command exceeds the torque set in Pn132, the speed loop will be switched to P control.

The factory torque command value is set to 200%.

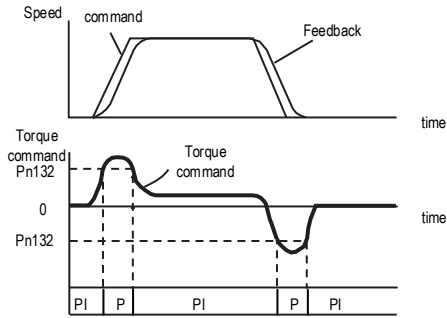

When the switching condition of the mode switch is set as speed command, if the speed command exceeds the speed set in Pn133, the speed loop will be switched to P control.

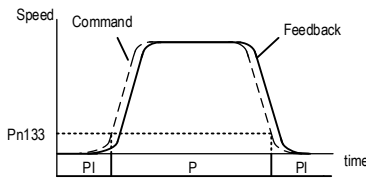

When the switching condition of the mode switch is set as acceleration, if the speed command exceeds the acceleration set in Pn134, the speed loop will be switched to P control.

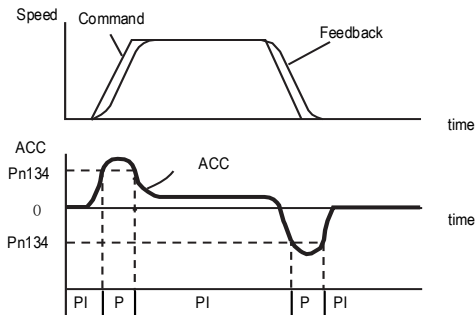

When the switching condition of the mode switch is set as the position deviation, if the position deviation exceeds the value set in Pn135, the speed loop will be switched to P control.

This setting is valid only under position control.

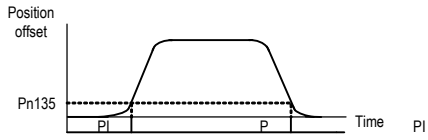
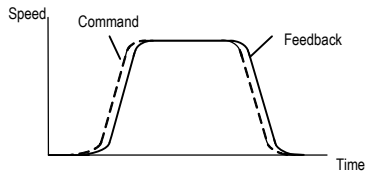

7 Auxiliary Functions

7.1 List of Auxiliary Functions

The auxiliary functions are used to execute the functions related to the operation and adjustment of the servo motor. Each auxiliary function has a number starting with Fn.

The following table lists the auxiliary functions and reference items.

Auxiliary function Code	Function description
Fn 000	Alarm record display
Fn 001	Clear alarm record
Fn 002	Software reset
Fn 003	Restore factory parameters
Fn 005	JOG operation
Fn 006	Program JOG operation
Fn 100	Automatic adjustment of command offset
Fn 101	Speed command offset manual adjustment
Fn 102	Torque command offset manual adjustment
Fn 103	Current offset automatic adjustment
Fn 104	Current offset manual adjustment
Fn 105	Initialize the detected value of the vibration detection
Fn 303	Bandwidth setting
Fn 401	Easy FFT
Fn 402	Online vibration monitoring

7.2 Alarm Records Display (Fn000)

7.2.1 Overview

The alarm record function can record up to 10 alarms that have occurred in the servo unit. You can confirm the alarm code and time that occurs. (measurement of the duration of the control power supply and the main circuit power supply in 100ms increments, and the function to display the total operation time in the event of an alarm, It can be measured continuously for about 31 years if it is operated 24 hours per day and 365 days per year).



1. When the same alarm occurs continuously, if the interval between alarms is less than 1 hour, it will not be saved, and if it exceeds 1 hour, all will be saved.
2. When no alarm occurs, "□- -" is displayed on the panel operator.
3. The alarm record can only be cleared by "clear alarm record (Fn001)".

7.2.2 Operating Procedure

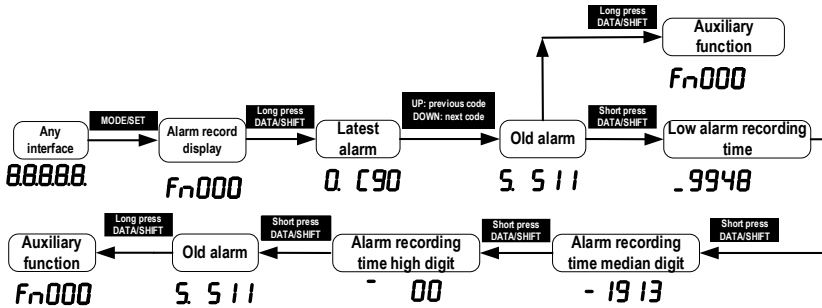

7.3 Clear Alarm Record (Fn001)

7.3.1 Summary

The alarm record of the servo unit can only be cleared by clearing the alarm record (Fn001) function. Alarm recording cannot be cleared by resetting the alarm or switching off the main circuit power of the servo unit.

7.3.2 Operating Procedure

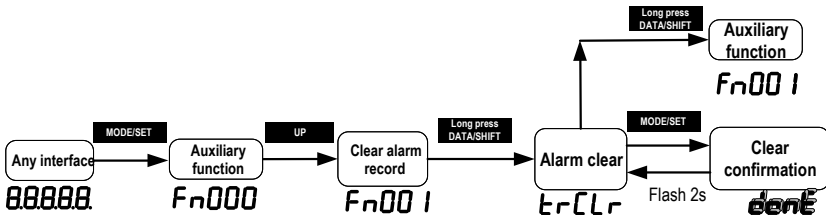

7.4 Software Reset (Fn002)

7.4.1 Summary

The function enables resetting the servo unit internally from software. It is used when it needs to re-power on or reset the alarm after changing the parameter setting. Parameter setting could also be enabled without re-power on.



1. This function must be operated in the state of servo OFF.
2. This function has nothing to do with the upper unit, and can reset the servo unit. Handling as when power is turned on. The servo unit will output the ALM signal, and other output signals may be changed forcibly.

7.4.2 Operating Procedure

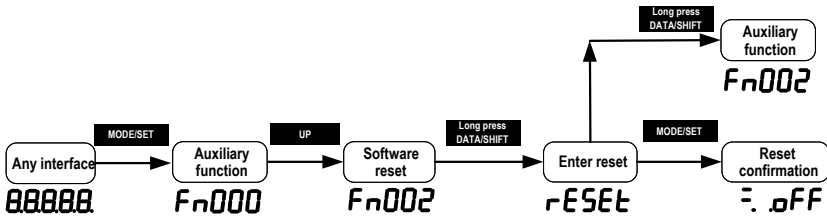

7.5 Restore Factory Parameters (Fn003)

7.5.1 Overview

The function is used to restore the parameters to the factory settings.



Cautions

1. The parameter initialization must be executed in the servo OFF state. It cannot be executed in the servo ON state. The initialization of parameter settings must be performed in the servo OFF state.
2. To make the setting effective, the power to the servo unit must be turned back on after operation.
3. The values adjusted by F_n100, F_n101, F_n102, F_n103, and F_n104 will not be initialized when this function is executed.

7.5.2 Operating Procedure

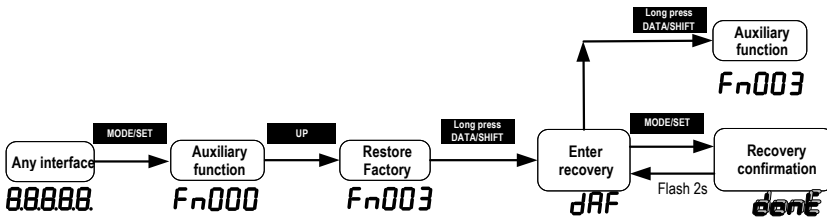

7.6 JOG Operation (Fn005)

7.6.1 Overview

The JOG operation is a function that confirms the operation of the servo motor under speed control without connecting to a host device.

To perform JOG operation, the following confirmation must be made in advance:

- The motor is in the enabled state and the Jog operation is invalid during the operation.
- The load inertia is suggested not more than 30 times of the motor inertia; otherwise it may cause large mechanical vibration.
- Parameter P_n500, P_n310, P_n311 set the Jog speed, acceleration and deceleration time;

default Jog speed is 500rpm.

Function code	Parameter name	Range	Defaults	Unit	Communication address	When enabled
Pn500	Jog speed	0 ~ 1000	500	rpm	0x0500	Immediately
Pn310	Speed command trapezoidal acceleration time	0 ~ 10000	0	ms	0x0310	Immediately
	Set the time required to accelerate from 0 r/min to the maximum speed (corresponding to the motor model). When the given speed is greater or less than the max speed, the actual acceleration time is calculated in proportion.					
Pn311	Speed command trapezoidal deceleration time	0 ~ 10000	0	ms	0x0311	Immediately
	Set the time required to decelerate from the maximum speed (corresponding to the motor model) to 0 r/min. When the given speed is greater or less than the max speed, the actual deceleration time is calculated in proportion.					



The overtravel prevention function is not available during JOG operation. The operating range of the machinery used must be considered while running.

7.6.2 Operating Procedure

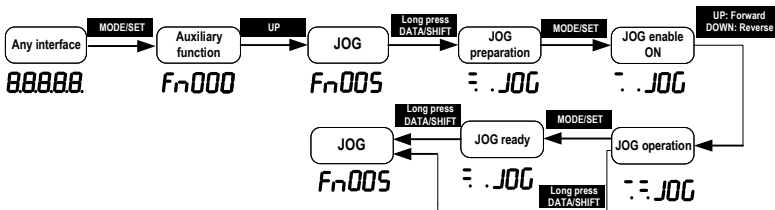

7.7 Program JOG Operation (Fn006)

7.7.1 Overview

Program JOG operation is a function that continuously runs with the preset operation mode, movement distance, movement speed, acceleration/deceleration time, waiting time, and number of

times of movements. Same as JOG operation (Fn005), do not connect to the host device during setting while using this function. It could confirm the operation of the servo motor and perform simple positioning operations.



1. Program JOG runs as position control, gear ratio and position command filtering are valid, but it is not possible to input pulse command to the servo. The pulse command cannot be input to the servo unit.
2. Overtravel prevention function is effective.

7.7.2 Operating Procedure

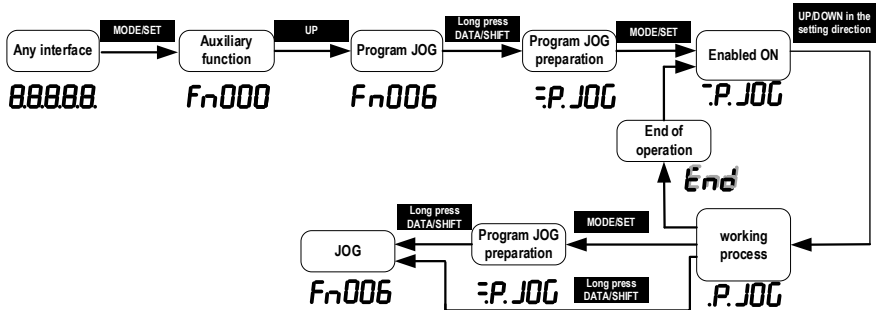

7.8 Automatic Adjustment of Command Offset (Fn100)

7.8.1 Overview

The automatic adjustment command offset is a method of automatically adjusting the command voltage after measuring the offset.

The measured offset will be stored in the servo unit.



1. Servo is in OFF state.
2. The bias adjustment is out of range or the voltage command is input during the bias adjustment, the adjustment may fail.

7.8.2 Operating Procedure

Turn off the servo drive and input the 0V command voltage from the host device or external circuit.

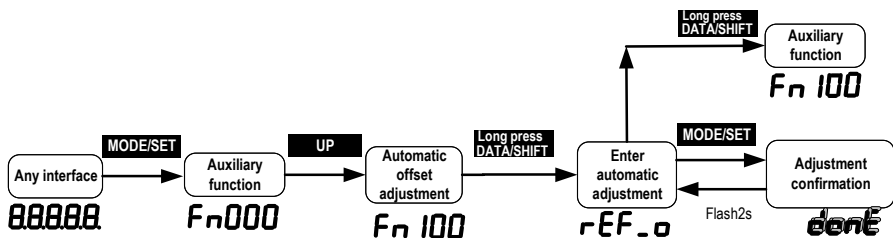

7.9 Speed command Offset Manual Adjustment (Fn101)

7.9.1 Overview

The method of directly inputting the command offset for adjustment.

Manual adjustments are used for the following occasions:

- The host device has built a position loop and when the position deviation of the servo lock stop is set to zero.
- When you need to set an offset.
- When confirming the offset set by automatic adjustment.

7.9.2 Operating Procedure

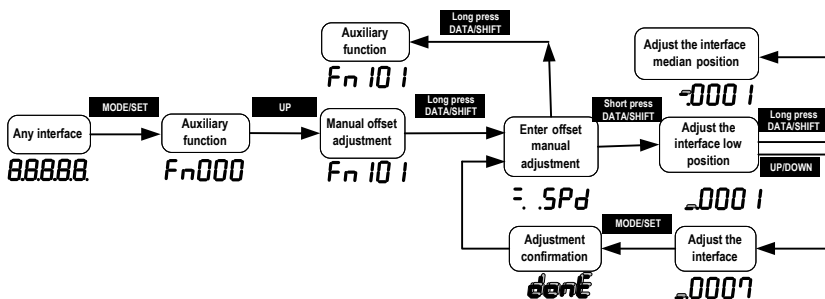

7.10 Torque Command Offset Manual Adjustment (Fn102)

7.10.1 Overview

It is a method of directly input the torque command offset.

Manual adjustments are used for the following occasions:

- When you need to set an offset.
- When confirming the offset set by automatic adjustment.

7.10.2 Operating Procedure

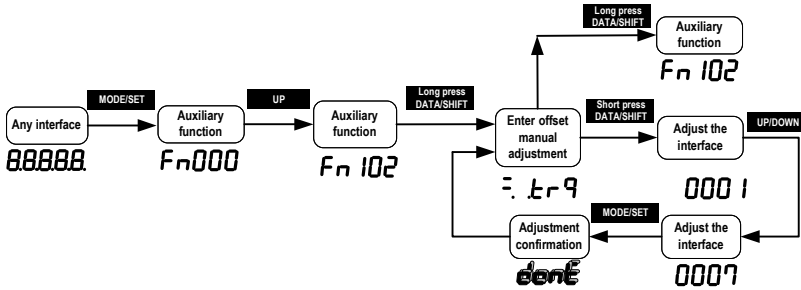

7.11 Current Offset Automatic Adjustment (Fn103)

7.11.1 Overview

This function is only used when it is necessary to further reduce the torque ripple and other adjustments that need to be performed with higher precision, and usually does not require adjustment.

!

Cautions

1. The automatic adjustment of the motor current detection signal offset must be performed while the servo is off.
2. When the generated torque ripple is significantly larger than other servo units, perform automatic adjustment of the offset.

7.11.2 Operating Procedure

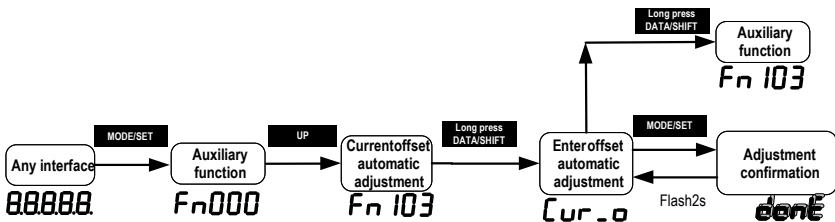

7.12 Current Offset Manual Adjustment (Fn104)

7.12.1 Overview

This function is used only when the torque ripple is still large after the motor current detection signal offset automatic adjustment (Fn103) is executed.



If this function is performed incorrectly during manual adjustment, the characteristics may be degraded. When performing manual adjustment, observe the following precautions.

- Make the servo motor speed approximately 100 min⁻¹.
- Observe the torque command in the analog monitoring state and adjust the pulsation to the minimum. The offset of the U current and V current of the servo motor must be adjusted in a balanced manner. Please repeat the adjustment several times alternately.

7.12.2 Operating Procedure

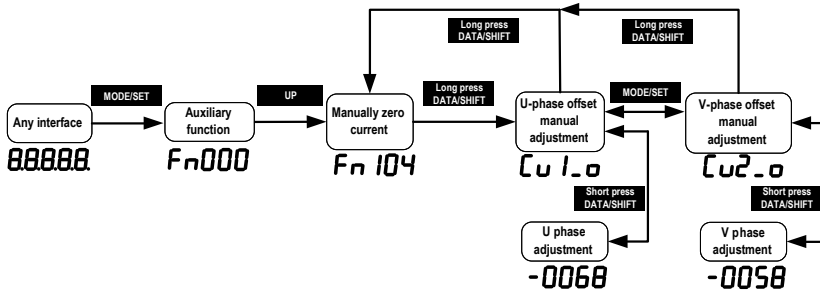

7.13 Initializing the Detection Value of Vibration Detection (Fn105)

7.13.1 Overview

The vibration detection function can detect the vibration in the feedback speed of the servo motor. This function is used to detect the “vibration warning (Er. 520)” and “vibration alarm (AL. 911)” that is more accurately after detecting the machine vibration in the running state, and the function also could be used to automatically set the vibration detection value (Pn187).

Related parameters as below:

Function code	Parameter	Range	Defaults	Unit	Communication address	When enabled
Pn185	Vibration detection options	0x00 ~ 0x02	0	-	0x0185	Immediately
	This function is to automatically detect related alarms or warnings after detecting machine vibration under normal operating conditions. Set the servo action after vibration is detected: 0-No vibration detection. 1-Warning after vibration is detected. 2-Alarming after vibration is detected.					
Pn186	Vibration detection	50 ~ 500	100	%	0x0186	Immediately

	sensitivity					
	Set the sensitivity of the vibration detection. The smaller the setting value is, the more sensitive it is. If the setting is too small, the vibration may be detected by mistake during normal operation. Note: The detection sensitivity of vibration alarm and vibration warning may vary according to different mechanical conditions.					
Pn187	Vibration detection value	0 ~ 5000	50	rpm	0x0187	Immediately
	Set the threshold for vibration detection. The smaller the setting is, the easier it is to detect the vibration. If the setting is too small, the vibration may be detected by mistake during normal operation. Note: The vibration detection values of vibration alarm and vibration warning may vary according to different mechanical conditions.					



When the servo gain is set incorrectly, it may be difficult to detect the vibration. And it may not be possible to detect all the vibrations that have occurred.
When you set the improper moment of inertia ratio (Pn100), vibration warnings and vibration alarms may be detected by mistake or not detected.
This operation is performed when the motor is operated with actually used instructions.
When performing this action, make sure that the motor runs at a maximum speed of 10% or more.

7.13.2 Operating Procedure

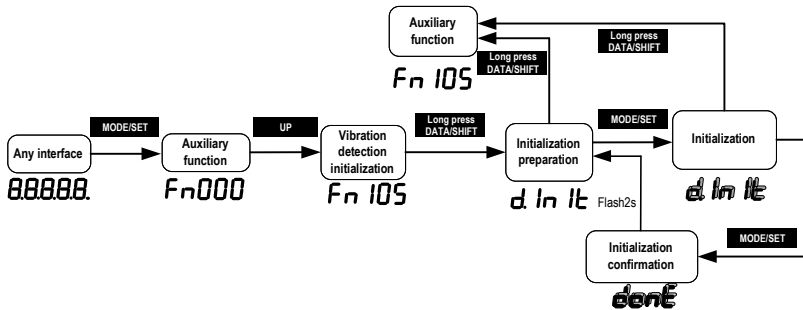

7.14 Bandwidth Settings (Fn303)

7.14.1 Overview

Bandwidth setting is a method of inputting a speed command or position command from the upper unit and manually adjusting it while running. By adjusting one or two values with the bandwidth setting, the setting value of the related servo gain can be adjusted automatically.

The bandwidth setting adjusts the following items:

- Gain adjustment (speed loop gain, position loop gain, etc.)
- Filter adjustment (Torque command filter, notch filter)

- Friction compensation
- Medium frequency vibration suppression control
- Low frequency vibration suppression
- Use the bandwidth setting when satisfactory response characteristics are not obtained by intelligent setting. If you want to further fine-tune each servo gain after adjusting the bandwidth setting, see "Manual tuning" for details and perform manual tuning.

7.14.2 Operating Procedure

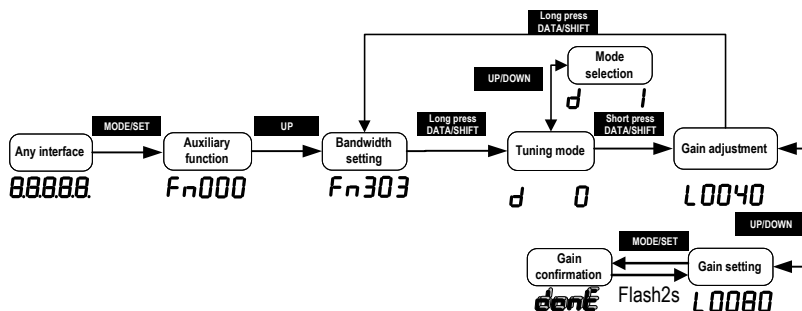

7.15 EasyFFT (Fn401)

7.15.1 Overview

EasyFFT transfers the periodic waveform commands from the servo unit to the servo motor, and slightly rotates the servo motor several times over a certain period, causing the machine vibration. The servo unit detects the resonance frequency basing on the vibration generated by the machine, and then sets the corresponding notch filter according to the resonance frequency. The notch filter effectively eliminates high-frequency vibrations and noise. If vibration occurs with a loud sound (abnormal sound) during operation, perform this function after the servo is turned off.



1. It must be used in the low gain state such as the initial stage of servo adjustment. If you perform the EasyFFT function after setting a high gain, the machine may vibrate due to mechanical characteristics and gain balance.
2. The detected resonance frequency can be automatically set to the notch filter 1/2. If 1 has been set, it will be automatically set to 2. If 1/2 are both set, the notch filter cannot be set by this operation.
3. When changing the amplitude setting value, gradually increase the amplitude value and change it while observing the situation.

7.15.2 Operating Procedure

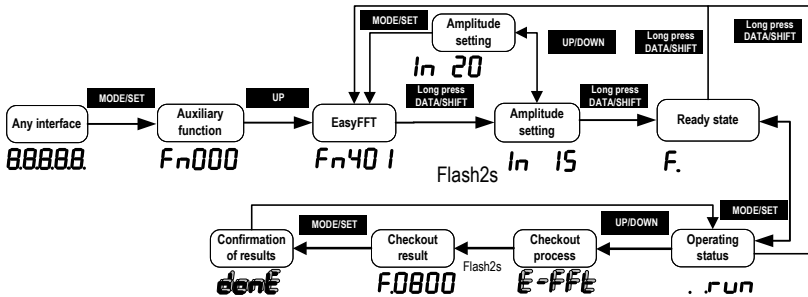

7.16 Online Vibration Monitoring (Fn402)

7.16.1 Overview

When the servo is ON and vibration occurs during operation, this operation can set the notch filter 1 or the torque command filter according to the vibration frequency, sometimes eliminating the vibration. Detect the vibration frequency of noise caused by mechanical resonance and display the vibration frequency with large peak on the operator. The effective torque command filter or notch filter 1 frequency for the vibration frequency will be automatically selected and the related parameters are automatically set.

When using the PC debugging software to adjust, it is recommended to perform the smart setting or bandwidth setting. Generally, no manual operation is required. Only when the PC debugging software is not available, it is key-assisted.

7.16.2 Operating Procedure

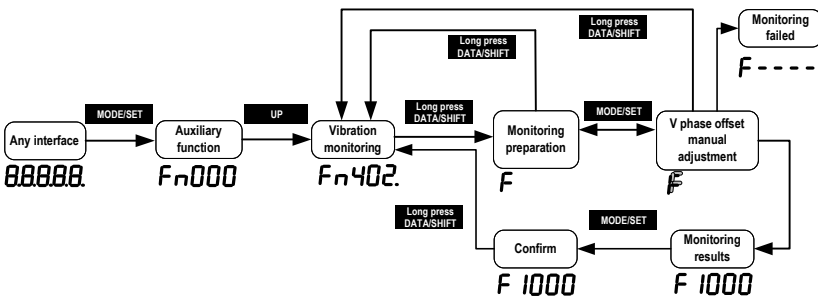

8 Home Position Return and Internal Positions

8.1 The Principle of Home Position Return Function

The home position return function is the process that the servo drive controls the motor to find and return to the home or zero point according to the set way in the position mode.

Home position: the starting position of servo motor operation. The limit signal, DI input signal or encoder Z pulse can be used mechanically as the home position.

Zero point: it defines the position offset from a certain position of the home position signal as the zero point position. The zero position is the zero value during the operation of the servo drive.

The home position return function is to find the home position of the motor on the machine according to the set home position return method. After finding the home position, it runs to the zero position according to the set zero position offset pulse, and uses the zero position as the starting position for subsequent motor operation.

According to the above home position definition, the home position signal source can be given in three ways: limit signal, DI input signal and Z pulse. The mechanical home position signal can generally be expressed by a level signal with a certain pulse width. A high level indicates that the signal is valid, and a low level indicates that the signal is invalid. In order to accurately locate the home position signal, when selecting the home position signal source, you need to select the forward or reverse rising edge of the home position signal source as the home position signal, as shown in the figure 1 below:

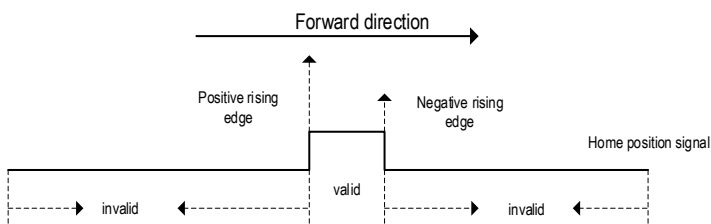

Figure 1 Home position signal source and signal edge selection diagram

During the home position return process, it is necessary to encounter the home position signal multiple times to determine the correct home position. When starting the home position return, given a relatively large speed for the home position return to ensure the speed of finding the home position. Define the first time that encounters the home position signal as the deceleration point. After encountering the deceleration point, the home position return speed is reversed to a low speed to ensure the accuracy of finding the home position. If encountering the home position signal again at low speed, it means that the home position is found. In the actual process, the accuracy of the home position is affected by finding the home position at low speed. The higher the speed when finding the home position at low speed, the greater the pulse deviation of the home position signal edge. In order to determine the home position signal more accurately, the Z signal of the encoder can be used as the home position signal, and define the second time that encounters the Z pulse near the home position signal as the home position signal, so that the home position is accurate and without deviation.

According to the home position signal source, home position signal edge, home position return

direction, deceleration point type, Z pulse direction, whether or not Z pulse is used, and encountering the limit, the home position return method can be classified as the following table 1:

Home position return methods	Coding table of 35 home position return methods		Find DI signal														Reserved		Find limit signal		Find DI signal														Find home position directly	
	1	2	3	4	5	6	7	8	9	10	11	12	13	14	15	16	17	18	19	20	21	22	23	24	25	26	27	28	29	30	31	32	33	34		
Switch	1	2	3	4	5	6	7	8	9	10	11	12	13	14	15	16	17	18	19	20	21	22	23	24	25	26	27	28	29	30	31	32	33	34		
0.2 pulse 1-home position 2-limit	10	10	01	01	01	01	01	01	01	01	01	01	01	01	11	11	10	10	01	01	01	01	01	01	01	01	01	01	01	01	11	11	00	00		
Start direction 0+POS 1-NEG	1	0	0	0	1	1	0	0	0	0	1	1	1	1	---	---	1	0	0	0	0	0	0	0	0	0	0	1	1	1	1	---	---	0		
Switch edge 0+POS rising 1-NEG rising	1	0	0	0	1	1	0	0	1	1	1	1	0	0	---	---	1	0	0	0	1	1	0	0	1	1	1	1	1	0	0	---	---	---		
End status 0+OFF 1-ON	0	0	0	1	0	1	0	1	1	0	0	1	1	0	---	---	0	0	0	1	0	1	0	1	1	0	0	1	1	0	---	---	---	---		
Z pulse home 0+NO 1+YES	1	1	1	1	1	1	1	1	1	1	1	1	1	1	---	---	0	0	0	0	0	0	0	0	0	0	0	0	0	0	---	---	1	1		
Z pulse direction 0+POS 1-NEG	0	1	1	0	0	1	1	0	1	0	0	1	0	1	---	---	---	---	---	---	---	---	---	---	---	---	---	---	---	---	---	---	---	0		
Limit process: 0+arming Reverse 1+Zrsvd	10	10	00	00	00	00	01	01	01	01	01	01	01	01	---	---	10	10	00	00	00	00	01	01	01	01	01	01	01	---	---	01	01	01		
Header: decimal coded value	128	152	051	031	020	070	081	081	093	0A8	0A0	070	085	085	003	003	102	102	001	001	009	019	081	091	098	098	080	080	095	095	003	003	084	0A0		
Home position return methods	1	2	3	4	5	6	7	8	9	10	11	12	13	14	15	16	17	18	19	20	21	22	23	24	25	26	27	28	29	30	31	32	33	34		

Table 1 Classification of home position return methods

Note: the definition of above 1 to 34 home position return methods is according to the CANopen protocol CIA402 standards, and is same as the home position return methods given in the CANopen protocol. The following describes the 1 to 34 methods of the home position return.

8.1.1 Home Position Return Trigger

The home position return trigger can automatically perform home position return via SI terminal trigger, point trigger, communication trigger and power-on.

8.1.2 Home Position Return SI Terminal Trigger

By configuring the universal SI terminal as the home position trigger function HomeTrig, the home position return is triggered. The rising edge of HomTrig could trigger the home return. The input function definition of SI terminal related to home return is shown in Table 2.1 below:

Table 2.1 SI terminal input function definition

SI Terminal Name	SI Terminal Function Code	Function Description
HomeTrig	0x1C	Home position return trigger function (valid on rising edge)
HomeReach	0x1D	External input home position signal (valid at high level)

Select the SI terminal as the home position trigger signal by configuring the general SI terminal function as 0x1C. When the rising edge of this SI terminal is valid, the home position return is triggered.

8.1.3 Home Position Return Automatically Trigger When Power On

The home position return function can be configured to automatically find the home position after the servo drive is powered on for the first time by configuring the function code Pn800. The function definition of Pn800 is shown in the figure below:

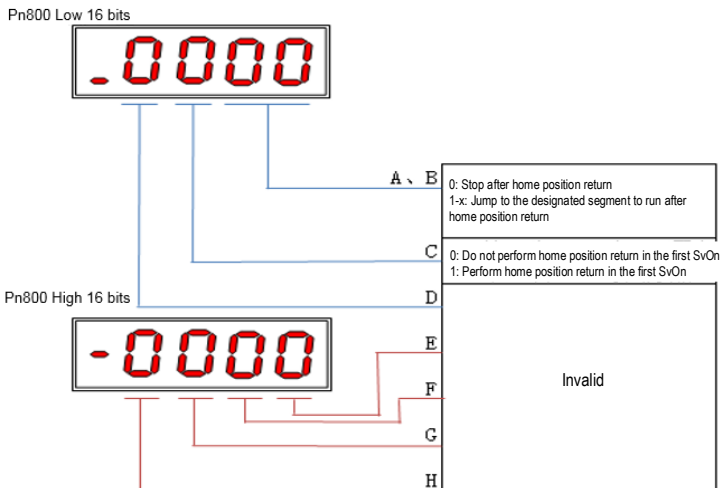

As shown in the figure above, section C of Pn800 is defined as home position return automatically trigger when power on. When the C segment is set to 1, it performs the home position return automatically when the servo is enabled for the first time.

The A and B sections of Pn800 are defined as the point number for automatic operation after the home position return is completed.

8.1.4 Home Position Return Triggered By Point Function

The home position return function can be triggered by the point function. The definitions of SI terminals related to point functions are shown in Table 2.3 below:

SI Terminal Name	SI Terminal Function Code	Function Description
PosTrig	0x16	Point trigger function (valid on rising edge)
PosBit0	0x17	Point segment number selection Bit0 (valid at high level)
PosBit1	0x18	Point segment number selection Bit1 (valid at high level)
PosBit2	0x19	Point segment number selection Bit2 (valid at high level)
PosBit3	0x1A	Point segment number selection Bit3 (valid at high level)
PosBit4	0x1B	Point segment number selection Bit4 (valid at high level)

Table 2.3 SI terminal point function definition

As shown in the above table, the point function is triggered by the external terminals. If the point segment number selection value is 0 when triggering, the home position return operation will be triggered. That is, when the rising edge of the PosTrig signal is valid, if the point segment number selection combination value is 0 (PosBit0 to PosBit4 are all 0), the home position return operation is triggered.

8.1.5 Communication Triggers Home Position Return

In addition to triggering the home return operation with the SI terminal, the home position return can also be triggered by communication. Through serial port communication, USB communication, keyboard operation, etc., the home position return operation is triggered in the case of writing 0 to the function code Pn898. Pn898 displays 10000 during the home position return process, and Pn898 displays 20000 after the home position return is completed.

Note: The home position return trigger is valid only when the servo drive is enabled. If the servo is not enabled, the home position return is invalid.

8.2 Home Position Return Function Code

Pn899	Home position return method selection	<input type="radio"/>	Address: 0x899
Factory default: 1	Setting range: 1~34	unit: N/A	Control mode: P

Parameter description: Home position return mode, any integer value between 1 and 34 can be

set.

Pn89A	Home position return high speed setting	○	Address:0x89A
Factory default:100	Setting range:0~2000	unit: rpm	Control mode: P

Parameter description: During the home position return process, set the high-speed home position search speed value.

Pn89B	Home position return low speed setting	○	Address:0x89B
Factory default:10	Setting range:0~1000	unit: rpm	Control mode: P

Parameter description: After encountering the home position signal at high speed, the home position signal is searched at the low speed in the reverse direction.

Pn89C	Home position return acceleration and deceleration time setting	○	Address:0x89C
Factory default:200	Setting range:10~1000	unit: ms	Control mode: P

Parameter description: The acceleration and deceleration time is given during the home position return process. The time from 0rpm to the rated speed is treated as the acceleration/deceleration time of the home position return.

Pn800	Home position return acceleration and deceleration time setting	○	Address:0x800
Factory default:0	Setting range: 0~0x0000FFFF	unit: N/A	Control mode: P

Parameter description: Pn800 function definition is shown in Figure 3 below.

Pn800 Low 16 bits



Pn800 High 16 bits



A、B

0: Stop after home position return
1-x: Jump to the designated segment to run after home position return

C

0: Do not perform home position return in the first SvOn
1: Perform home position return in the first SvOn

D

Invalid

E

F

G

H

Pn802	Zero point offset pulse value	○	Address:0x802
Factory default:0	Setting range:- 2147483648~2147483648	unit: command unit	Control mode: P

Parameter description: The pulse offset value that needs to be run after the home position signal is found during the home position return process.

8.3 Home Position Return Method

8.3.1 Home Position Return Method 1

a. Start the home position return → search for the reverse limit at high speed reverse direction → encounter the rising edge of reverse limit → decelerate to 0 → search for the falling edge of reverse limit at low speed forward direction → search for Z pulse in forward direction.

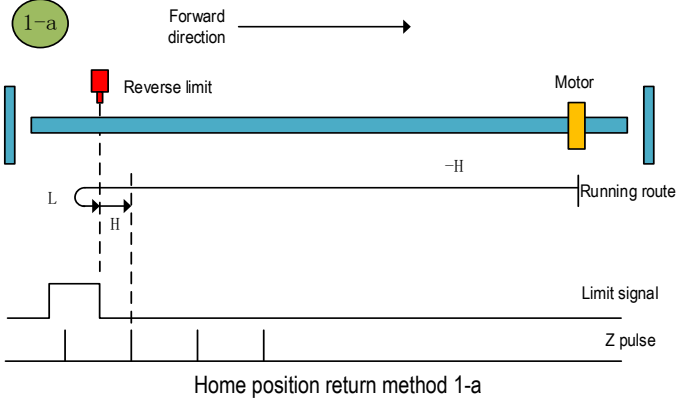

b. Start the home position return → reverse limit valid → Search for the falling edge of reverse limit at low speed forward direction → search for Z pulse in forward direction.

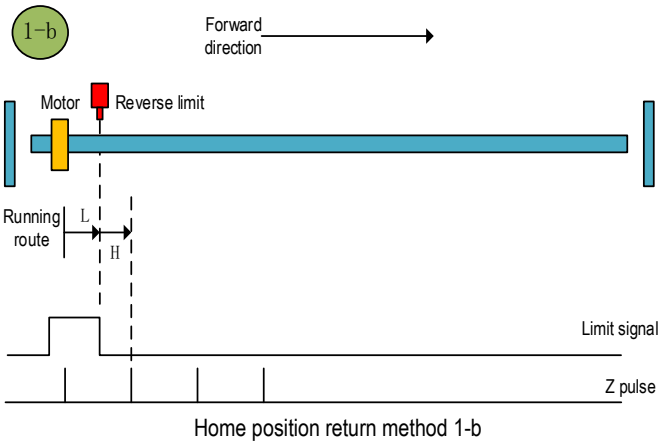

8.3.2 Home Position Return Method 2

- a. Start the home position return → search for the forward limit at high speed forward direction
 → encounter the forward limit rising edge → decelerate to 0 → search for the falling edge of forward limit at low speed reverse direction → search for Z pulse in reverse direction.

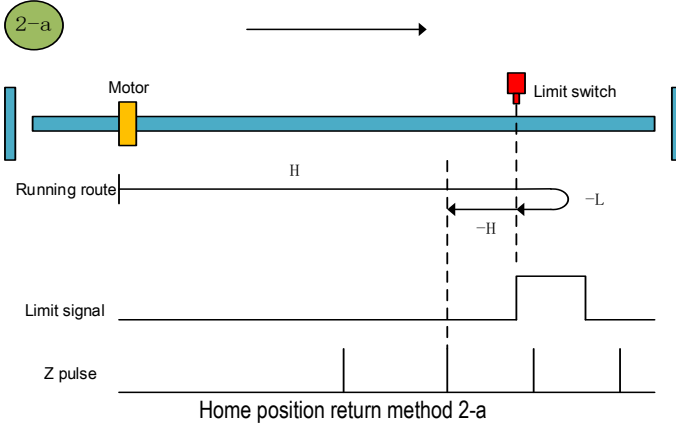

- b. Start the home position return → forward limit valid → search for the falling edge of forward limit at low speed reverse direction → search for Z pulse in reverse direction.

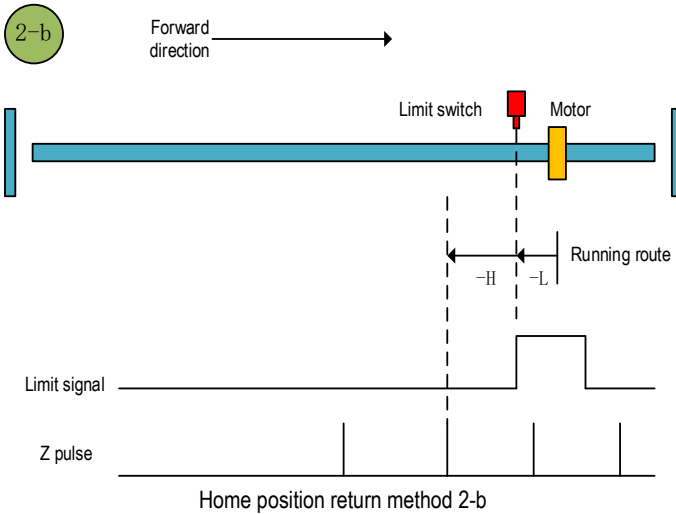

8.3.3 Home Position Return Method 3

a. Start the home position return → home position signal is OFF → search for the rising edge of home position signal at high speed forward direction → decelerate to 0 → search for the falling edge of home position signal at low speed reverse direction → search for Z pulse in reverse direction.

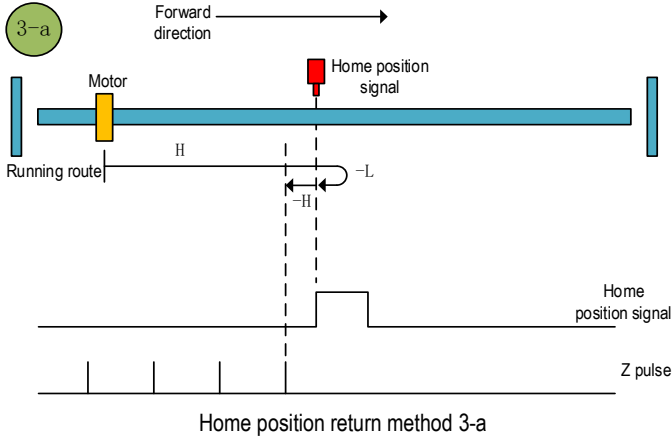

b. Start the home position return → Home position signal ON → Search for the falling edge of home position at low speed reverse direction → search for Z pulse in reverse direction.

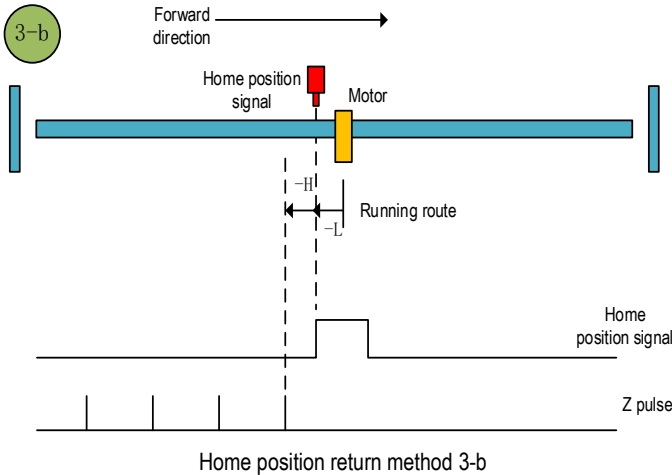

8.3.4 Home Position Return Method 4

a. Start the home position return → home position signal OFF → search for the rising edge of home position at high speed forward direction → decelerate to 0 → search for the falling edge of home position at low speed reverse direction → decelerate to 0 → search for the rising edge of home position at low speed forward direction → search for Z pulse in forward direction.

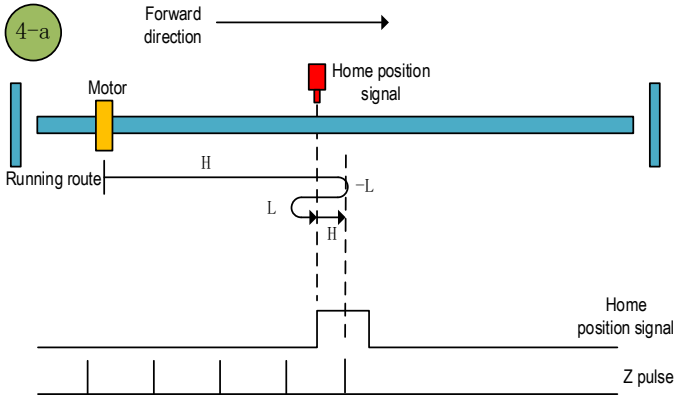

Home position return method 4-a

b. Start the home position return → home position signal ON → search for the falling edge of home position at low speed reverse direction → decelerate to 0 → search for the rising edge of home position at low speed forward direction → search for Z pulse in forward direction.

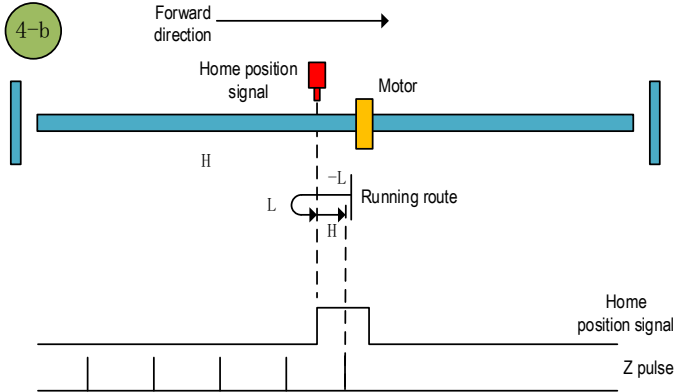

Home position return method 4-b

8.3.5 Home Position Return Method 5

a. Start the home position return → home position signal OFF → search for the rising edge of home position at high speed reverse direction → decelerate to 0 → search for the falling edge of home position at low speed forward direction → search for Z pulse in forward direction.

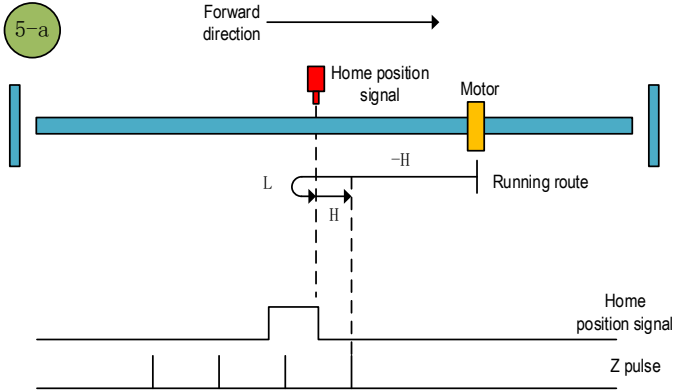

Home position return method 5-a

b. Start the home position return → home position signal ON → search for the falling edge of home position at low speed forward direction → search for Z pulse in forward direction.

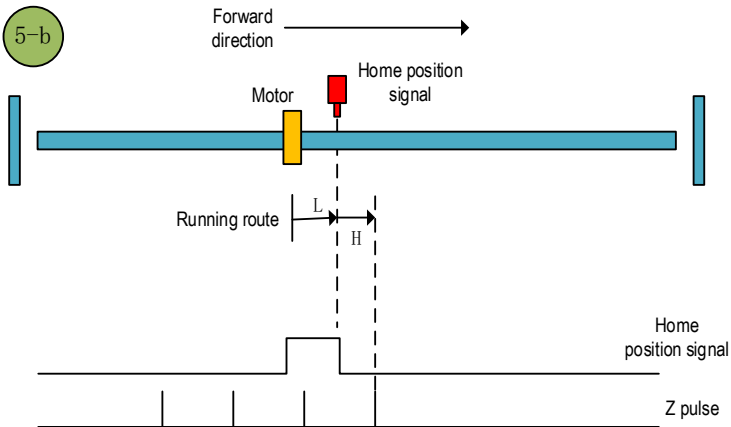

Home position return method 5-b

8.3.6 Home Position Return Method 6

a. Start the home position return → Home position signal OFF → Search for the rising edge of home position at high speed reverse direction → Decelerate to 0 → Search for the falling edge of home position at low speed forward direction → Search for the rising edge of home position at low speed reverse direction → Search for the Z pulse in reverse direction.

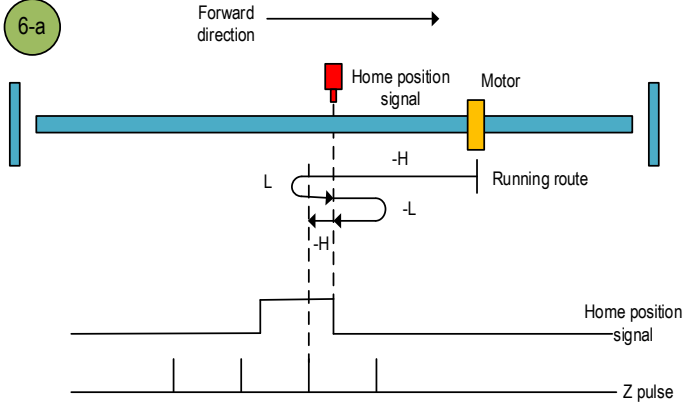

Home position return method 6-a

b. Start the home position return → Home position signal ON → Search for the falling edge of home position at low speed forward direction → Search for the rising edge of home position at low speed reverse direction → Search for the Z pulse in reverse direction.

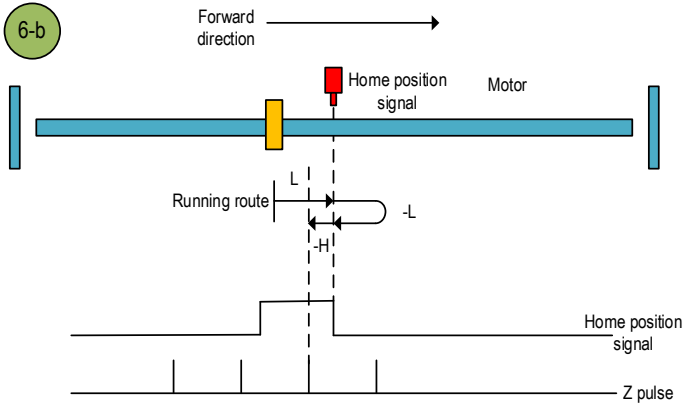

Home position return method 6-b

8.3.7 Home Position Return Method 7

a. Start the home position return → Home position signal OFF → Search for the rising edge of home position at high speed forward direction → Decelerate to 0 → Search for the falling edge of home position at low speed reverse direction → Search for the Z pulse in reverse direction.

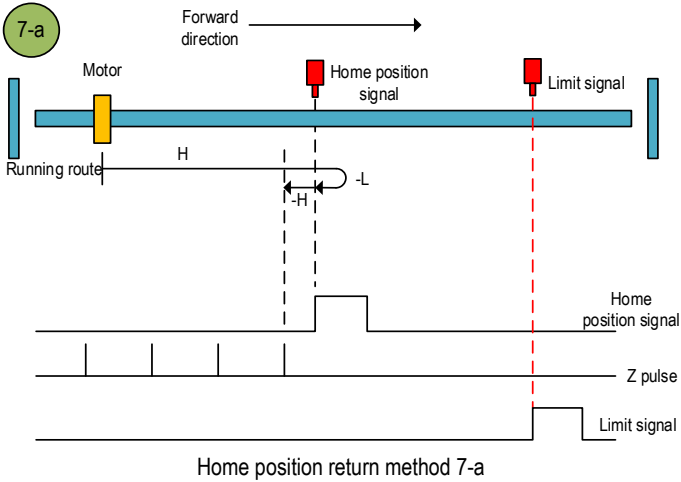

b. Start the home position return → Home position signal ON → Search for the falling edge of home position at low speed reverse direction → Search for the Z pulse in reverse direction.

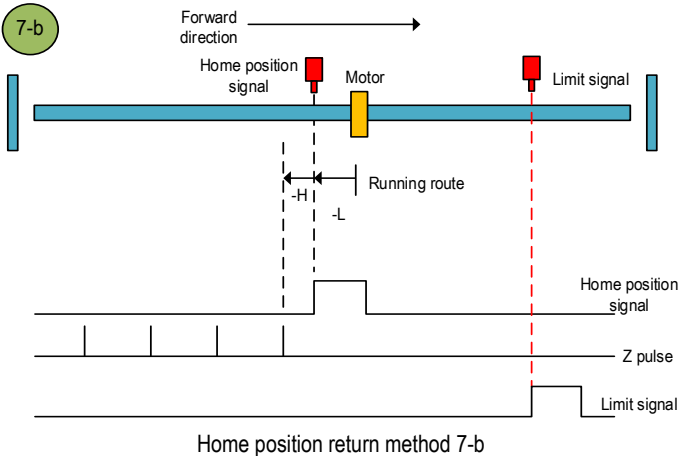

c. Start the home position return → Home position OFF → Search for the rising edge of home position at high speed forward direction → Touch the forward limit → Search for the falling edge of home position at high speed reverse direction → Decelerate to 0 → Search for the rising edge of home position at low speed forward direction → Search for the falling edge of home position at low speed reverse direction → Search for the Z pulse in reverse direction.

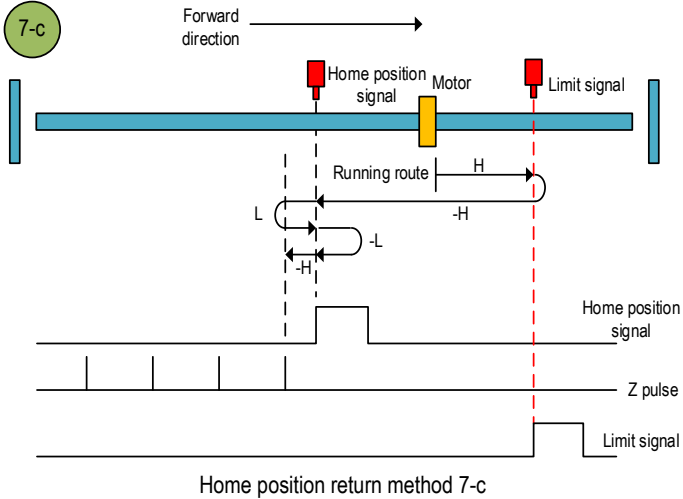

8.3.8 Home Position Return Method 8

a. Start the home position return → Home position signal OFF → Search for the rising edge of home position at high speed forward direction → Decelerate to 0 → Search for the falling edge of home position at low speed reverse direction → Search for the rising edge of home position at low speed forward direction → Search for the Z pulse in forward direction.

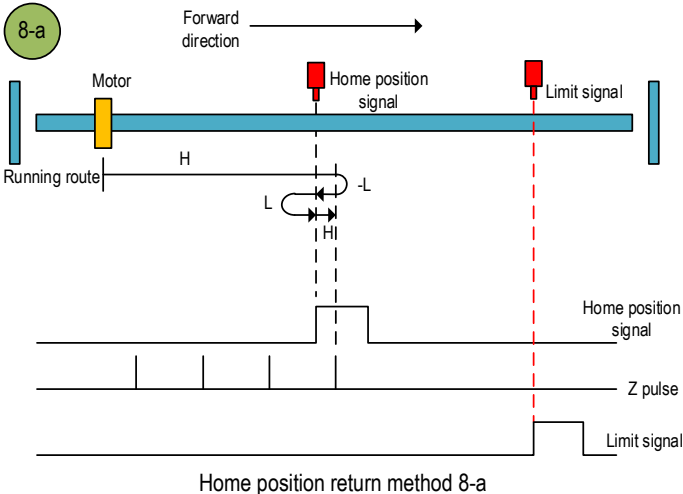

b. Start the home position return → Home position signal ON → Search for the falling edge of home position at low speed reverse direction → Search for the rising edge of home position at low speed forward direction → Search for the Z pulse in forward direction.

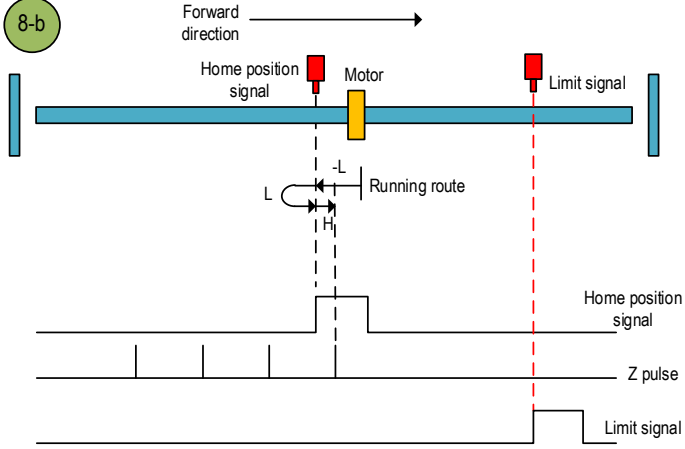

Home position return method 8-b

c. Start the home position return → Home position OFF → Search for the rising edge of home position at high speed forward direction → Touch the forward limit → Search for the falling edge of home position at high speed reverse direction → Decelerate to 0 → Search for the rising edge of home position at low speed forward direction → Search for the Z pulse in forward direction.

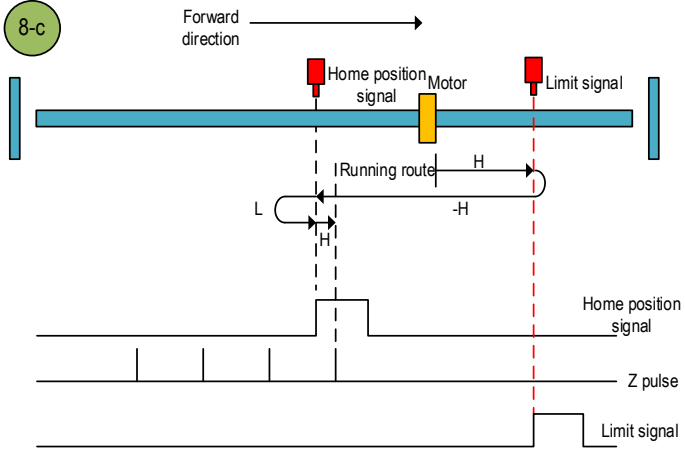

Home position return method 8-c

8.3.9 Home Position Return Method 9

a. Start the home position return → Home position signal OFF → Search for the falling edge of home position at high speed forward direction → Decelerate to 0 → Search for the rising edge of home position at low speed reverse direction → Search for the Z pulse in reverse direction.

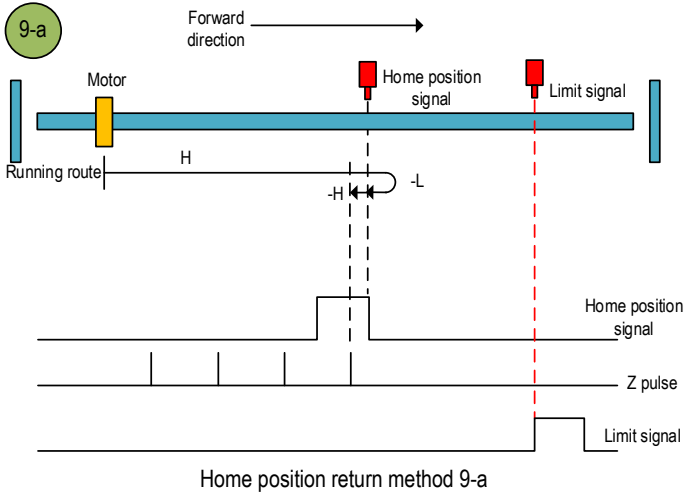

b. Start the home position return → Home position signal ON → Search for the falling edge of home position at high speed forward direction → Decelerate to 0 → Search for the rising edge of home position at low speed reverse direction → Search for the Z pulse in reverse direction.

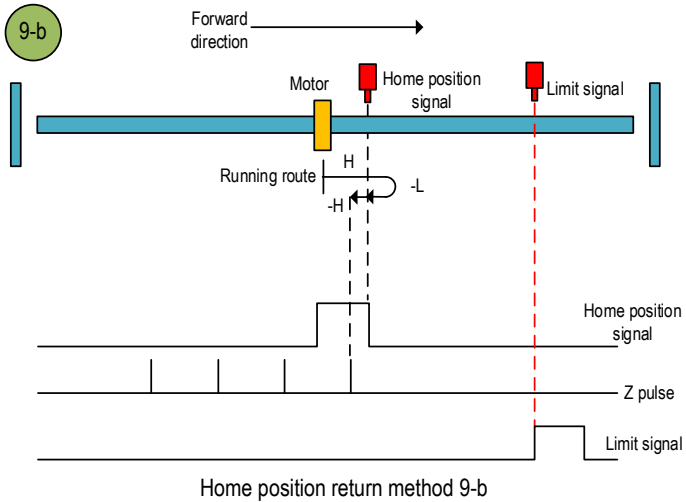

c. Start the home position return → Home position OFF → Search for the falling edge of home position at high speed forward direction → Touch the forward limit → Search for the rising edge of home position at high speed reverse direction → Decelerate to 0 → Search for the falling edge of home position at low speed forward direction → Search for the rising edge of home position at low speed reverse direction → Search for the Z pulse in reverse direction.

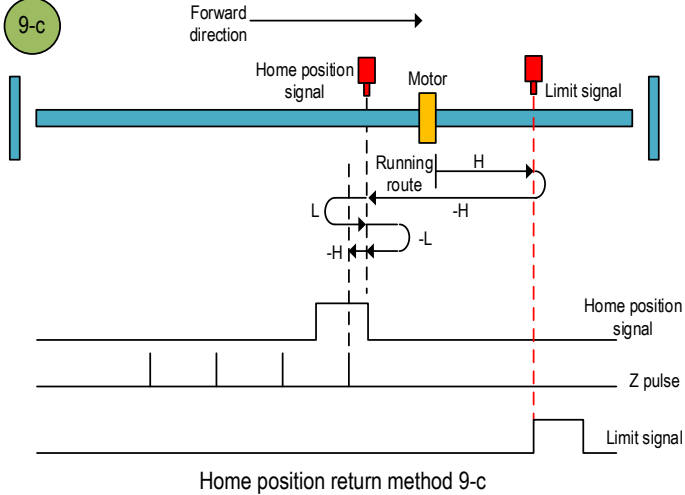

8.3.10 Home Position Return Method 10

a. Start the home position return → Home position signal OFF → Search for the falling edge of home position at high speed forward direction → Decelerate to 0 → Search for the rising edge of home position at low speed reverse direction → Search for the falling edge of home position at low speed forward direction → Search for the Z pulse in forward direction.

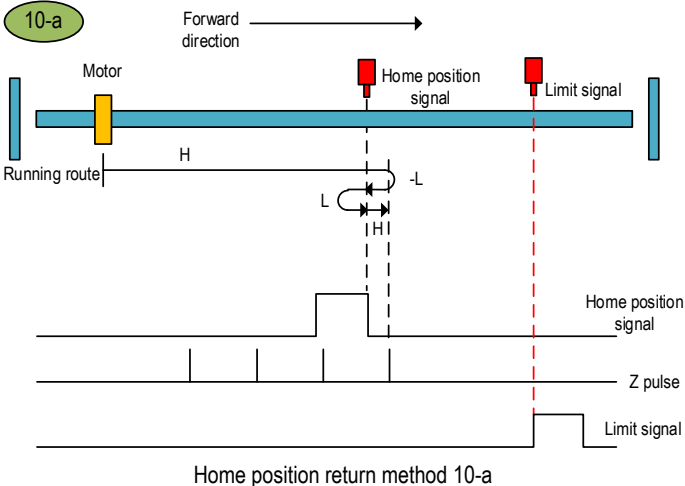



b. Start the home position return → Home position signal ON → Search for the falling edge of home position at high speed forward direction → Decelerate to 0 → Search for the rising edge of home position at low speed reverse direction → Search for the falling edge of home position at low speed forward direction → Search for the Z pulse in forward direction.

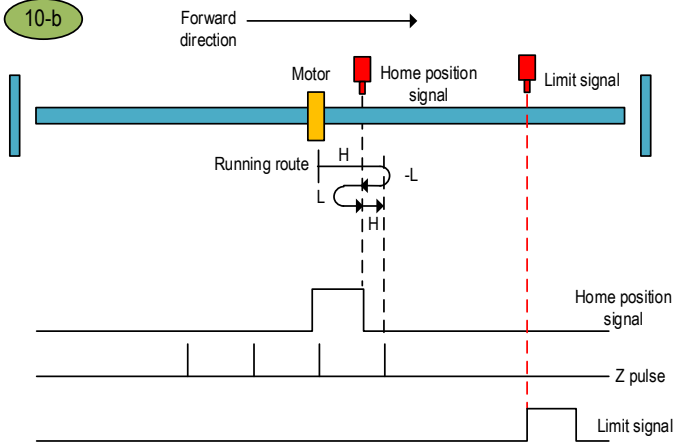

Home position return method 10-b

c. Start the home position return → Home position OFF → Search for the falling edge of home position at high speed forward direction → Touch the forward limit → Search for the rising edge of home position at high speed reverse direction → Decelerate to 0 → Search for the falling edge of home position at low speed forward direction → Search for the Z pulse in forward direction.

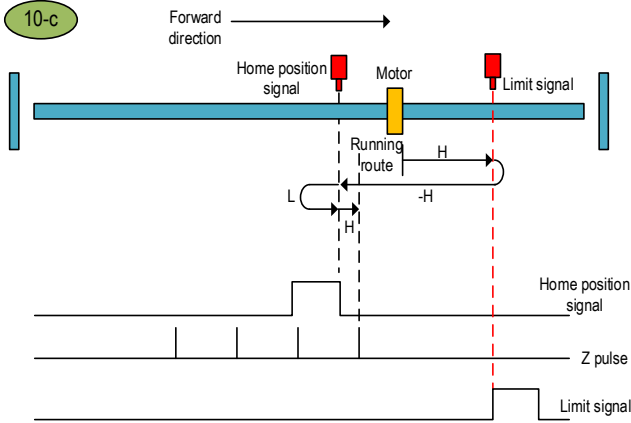

Home position return method 10-c

8.3.11 Home Position Return Method 11

a. Start the home position return → Home position signal OFF → Search for the rising edge of home position at high speed reverse direction → Decelerate to 0 → Search for the falling edge of home position at low speed forward direction → Search for the Z pulse in forward direction.

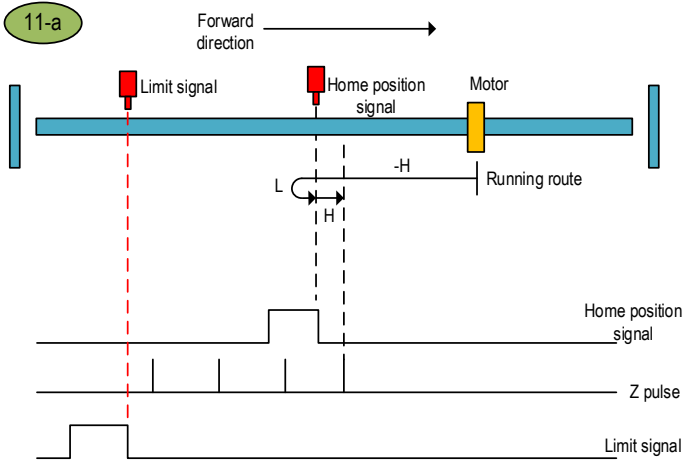

Home position return method 11-a

b. Start the home position return → Home position signal ON → Search for the falling edge of home position at low speed forward direction → Search for the Z pulse in forward direction.

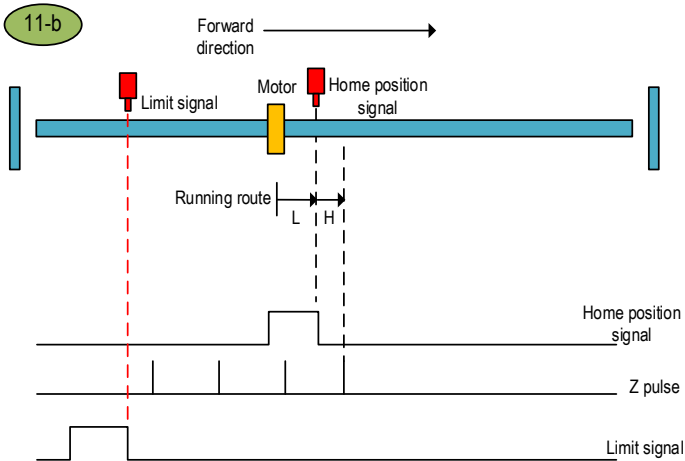

Home position return method 11-b

c. Start the home position return → Home position signal OFF → Search for the rising edge of home position at high speed reverse direction → Touch the reverse limit → Search for the falling edge of home position at high speed forward direction → Decelerate to 0 → Search for the rising edge of home position at low speed reverse direction → Search for the Z pulse in forward direction.

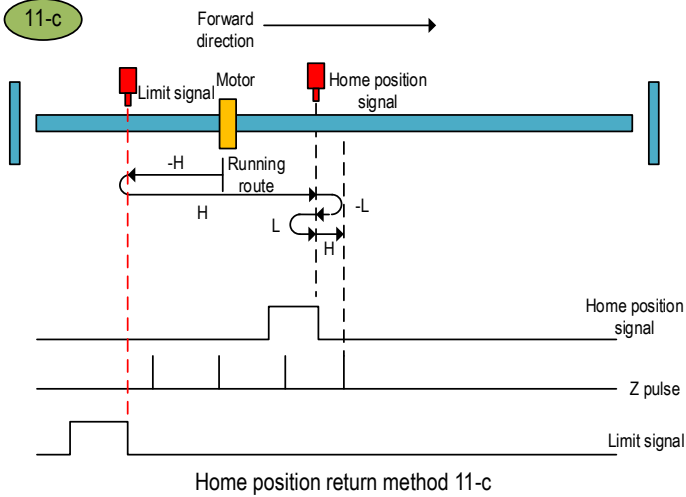

8.3.12 Home Position Return Method 12

a. Start the home position return → Home position signal OFF → Search for the rising edge of home position at high speed reverse direction → Decelerate to 0 → Search for the falling edge of home position at low speed forward direction → Search for the rising edge of home position at low speed reverse direction → Search for the Z pulse in reverse direction.

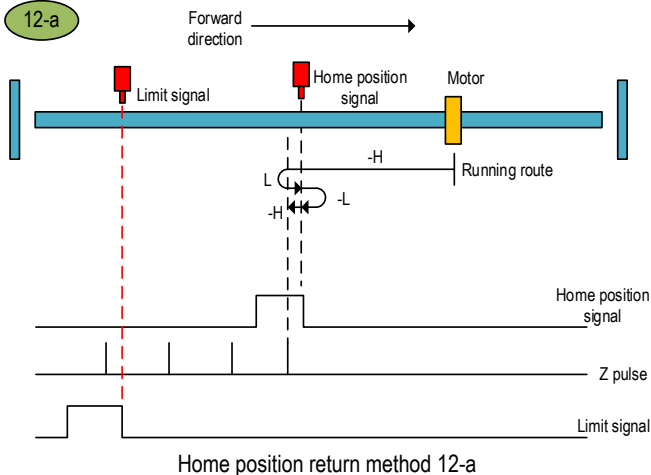

b. Start the home position return → Home position signal ON → Search for the falling edge of home position at low speed forward direction → Search for the rising edge of home position at low speed reverse direction → Search for the Z pulse in reverse direction.

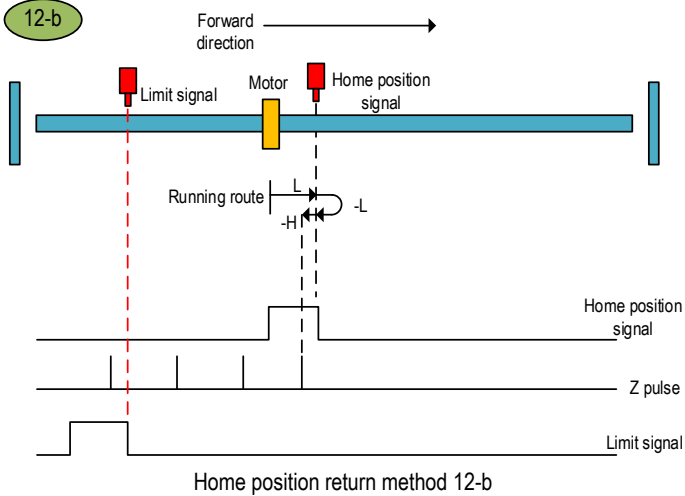

c. Start the home position return → Home position signal OFF → Search for the rising edge of home position at high speed reverse direction → Touch the reverse limit → Search for the falling edge of home position at high speed forward direction → Decelerate to 0 → Search for the rising edge of home position at low speed reverse direction → Search for the Z pulse in reverse direction.

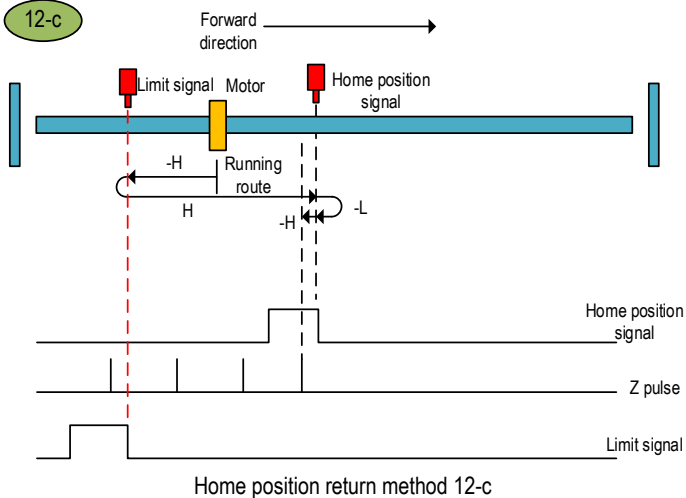

8.3.13 Home Position Return Method 13

a. Start the home position return → Home position signal OFF → Search for the falling edge of home position at high speed reverse direction → Decelerate to 0 → Search for the rising edge of home position at low speed forward direction → Search for the Z pulse in forward direction.

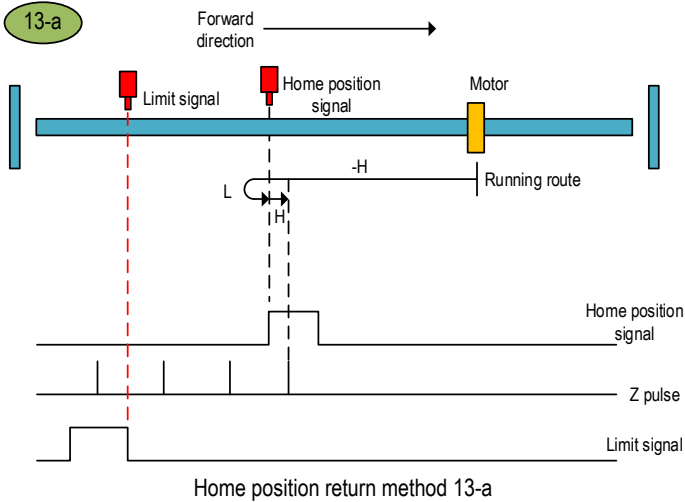

b. Start the home position return → Home position signal ON → Search for the falling edge of home position at high speed reverse direction → Decelerate to 0 → Search for the rising edge of home position at low speed forward direction → Search for the Z pulse in forward direction.

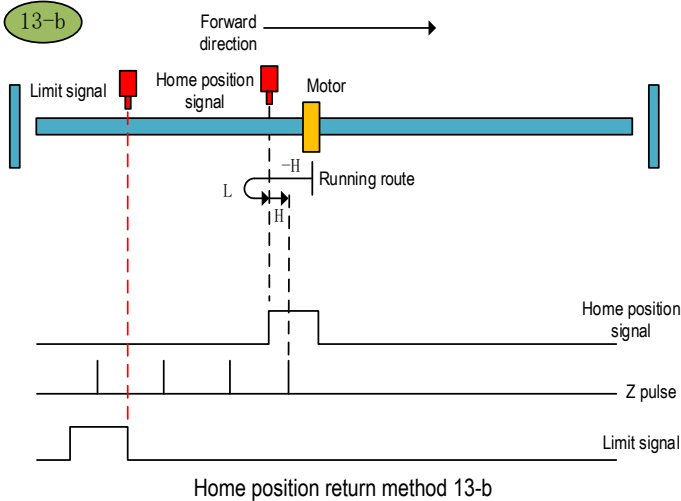

c. Start the home position return → Home position signal OFF → Search for the falling edge of home position at high speed reverse direction → Touch the reverse limit → Search for the rising edge of home position at high speed forward direction → Decelerate to 0 → Search for the falling edge of home position at low speed reverse direction → Search for the rising edge of home position at low speed forward direction → Search for the Z pulse in forward direction.

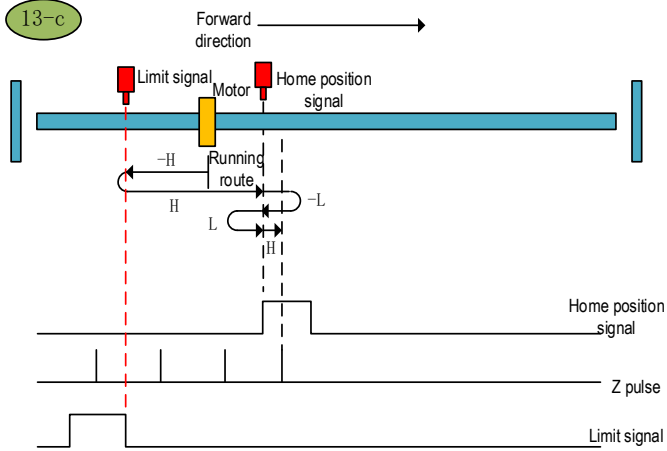

Home position return method 13-c

8.3.14 Home Position Return Method 14

a. Start the home position return → Home position signal OFF → Search for the falling edge of home position at high speed reverse direction → Decelerate to 0 → Search for the rising edge of home position at low speed forward direction → Search for the falling edge of home position at low speed reverse direction → Search for the Z pulse in reverse direction.

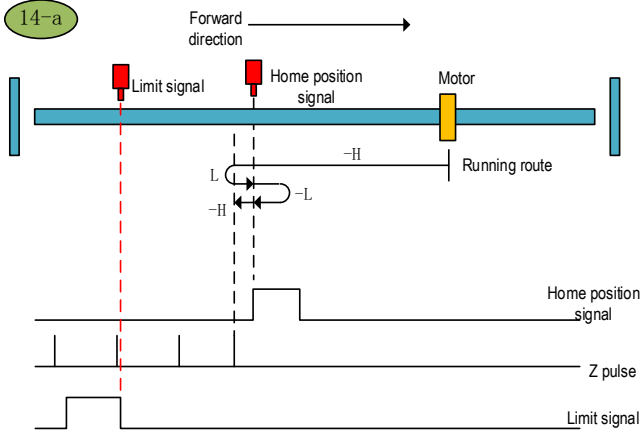

Home position return method 14-a

b. Start the home position return → Home position signal ON → Search for the falling edge of home position at high speed reverse direction → Decelerate to 0 → Search for the rising edge of home position at low speed forward direction → Search for the falling edge of home position at low speed reverse direction → Search for the Z pulse in reverse direction.

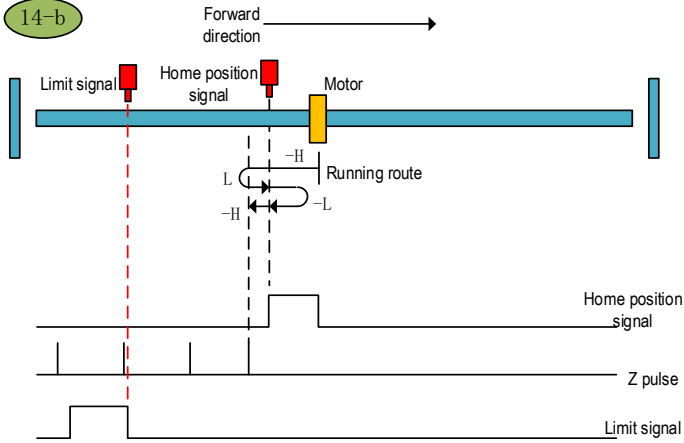

Home position return method 14-b

c. Start the home position return → Home position signal OFF → Search for the falling edge of home position at high speed reverse direction → Touch the reverse limit → Search for the rising edge of home position at high speed forward direction → Decelerate to 0 → Search for the falling edge of home position at low speed reverse direction → Search for the Z pulse in reverse direction.

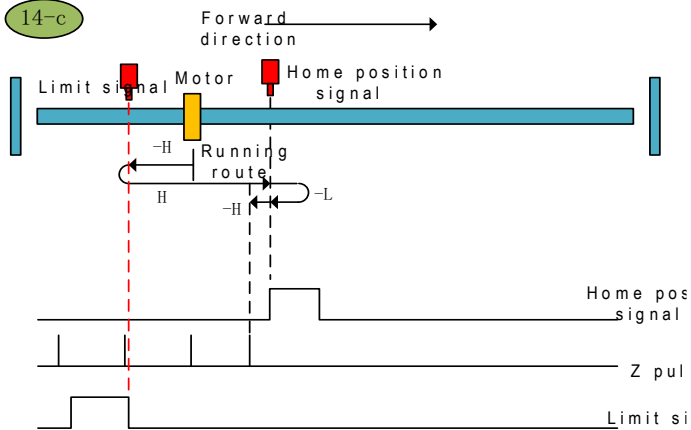

Home position return method 14-c

8.3.15 Home Position Return Method 15

After this home position return mode is triggered, the servo takes the current position as the home position and the servo absolute position is cleared (equivalent to the 35th home position return mode specified in CIA402).

8.3.16 Home Position Return Method 16: Reserved

8.3.17 Home Position Return Method 17

a. Start the home position return → Search for the reverse limit at high speed reverse direction → Touch the rising edge of reverse limit → Decelerate to 0 → Stop after searching for the falling edge of reverse limit at low speed forward direction.

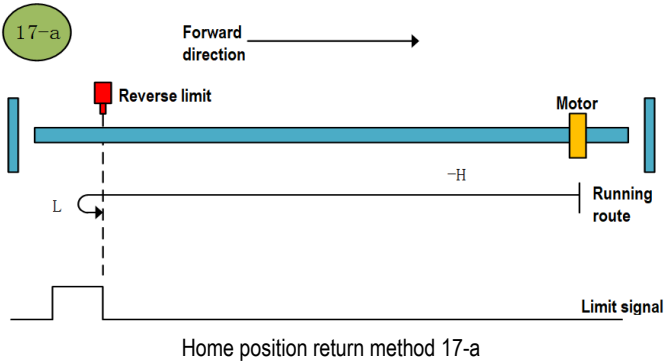

b. Start the home position return → Reverse limit valid → Stop after searching for the falling edge of reverse limit at low speed forward direction.

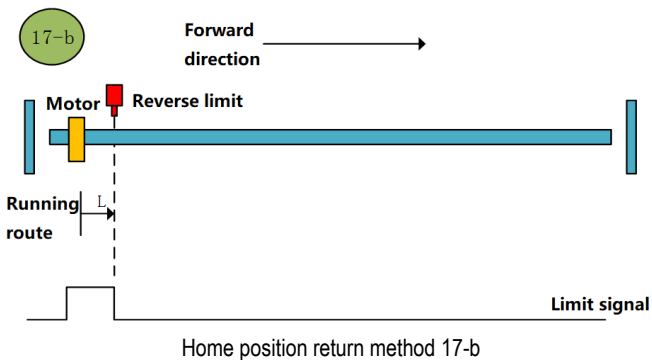

8.3.18 Home Position Return Method 18

a. Start the home position return → Search for the forward limit at high speed forward direction → Touch the rising edge of forward limit → Decelerate to 0 → Stop after searching for the falling edge of forward limit at low speed reverse direction.

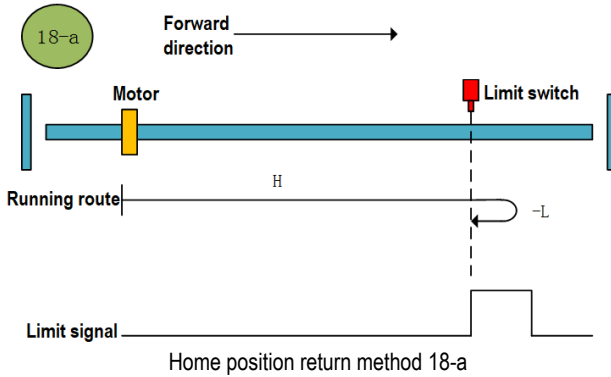

b. Start the home position return → Forward limit valid → Stop after searching for the falling edge of forward limit at low speed reverse direction.

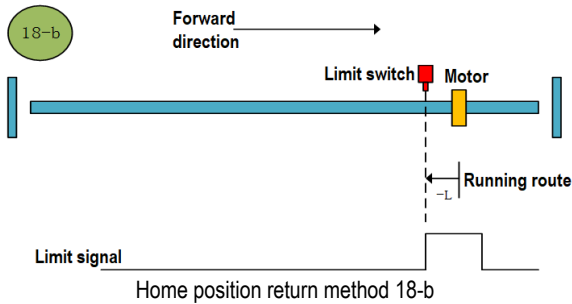

8.3.19 Home Position Return Method 19

a. Start the home position return → Search for the home position at high speed forward direction → Touch the rising edge of home position → Decelerate to 0 → Stop after searching for the falling edge of home position at low speed reverse direction.

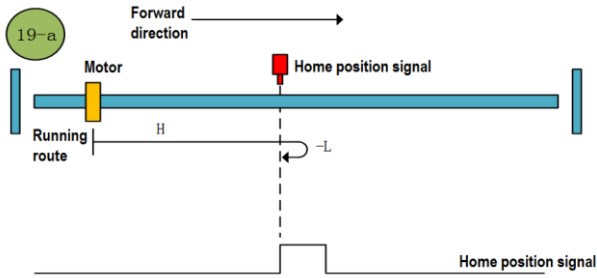

Home position return method 19-a

b. Start the home position return → Home position valid → Stop after searching for the falling edge of home position at low speed reverse direction.

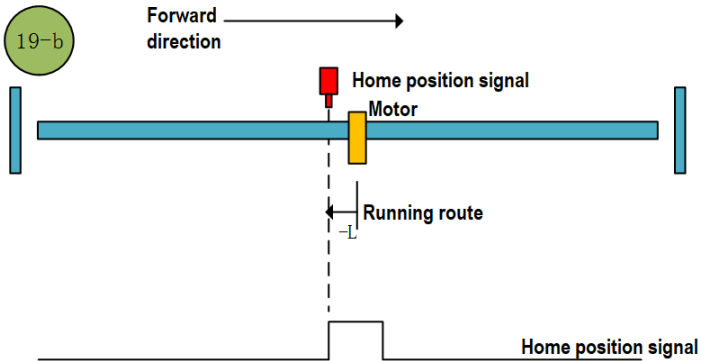

Home position return method 19-b

8.3.20 Home Position Return Method 20

a. Start the home position return → Home position signal OFF → Search for the rising edge of home position at high speed forward direction → Decelerate to 0 → Search for the falling edge of home position at low speed reverse direction → Stop after searching for the rising edge of home position at low speed forward direction.

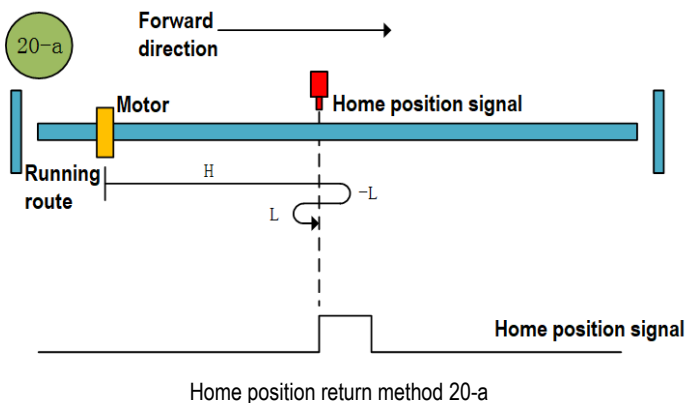

b. Start the home position return → Home position signal ON → Search for the falling edge of home position at low speed reverse direction → Stop after searching for the rising edge of home position at low speed forward direction.

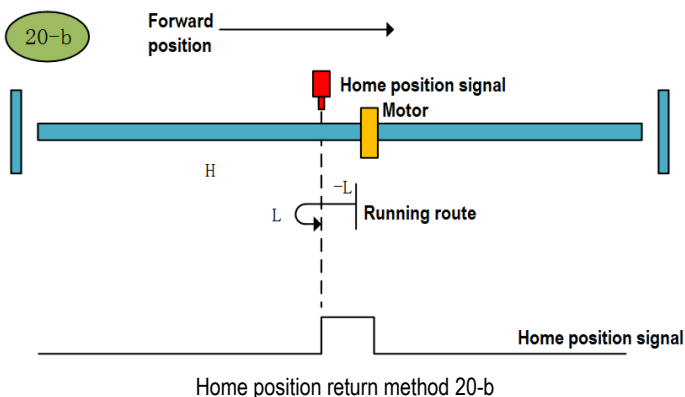

8.3.21 Home Position Return Method 21

a. Start the home position return → Home position signal OFF → Search for the rising edge of home position at high speed reverse direction → Decelerate to 0 → Stop after searching for the falling edge of home position at low speed forward direction.

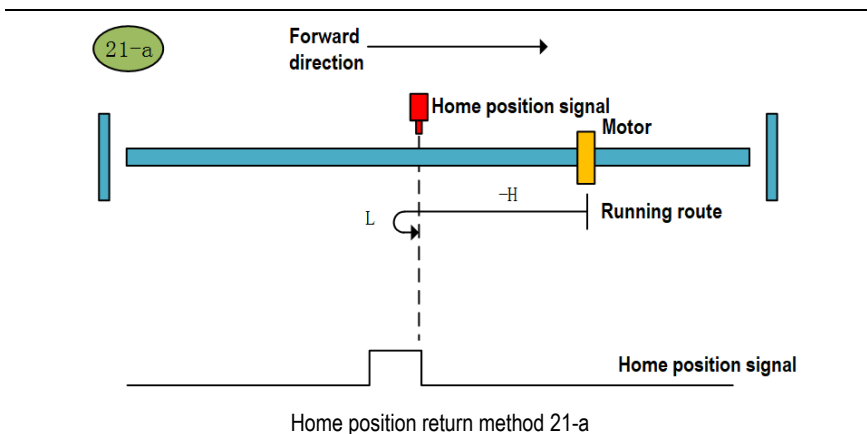

b. Start the home position return → Home position signal ON → Stop after searching for the falling edge of home position at low speed forward direction.

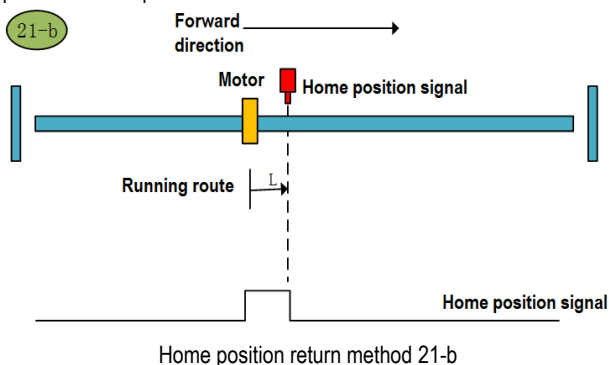

8.3.22 Home Position Return Method 22

a. Start the home position return → Home position signal OFF → Search for the rising edge of home position at high speed reverse direction → Decelerate to 0 → Search for the falling edge of home position at low speed forward direction → Stop after searching for the rising edge of home position at low speed reverse direction.

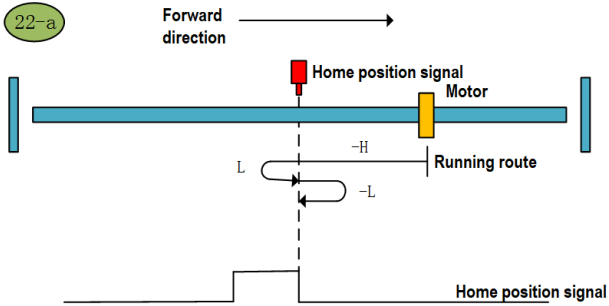

Home position return method 22-a

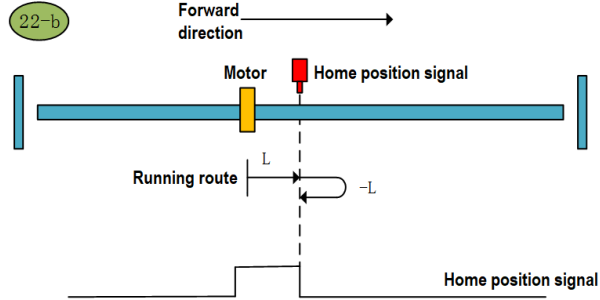

Home position return method 22-b

8.3.23 Home Position Return Method 23

a. Start the home position return → Home position signal OFF → Search for the rising edge of home position at high speed forward direction → Decelerate to 0 → Stop after searching for the falling edge of home position at low speed reverse direction.

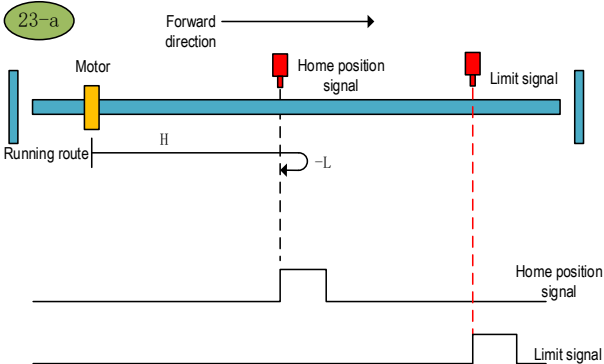

Home position return method 23-a

b. Start the home position return → Home position signal ON → Stop after searching for the falling edge of home position at low speed reverse direction.

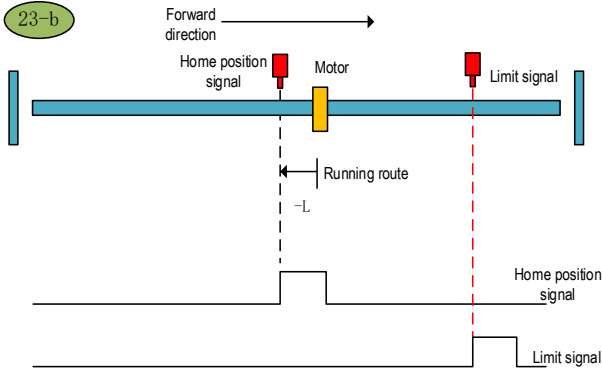

Home position return method 23-b

c. Start the home position return → Home position OFF → Search for the rising edge of home position at high speed forward direction → Touch the forward limit → Search for the falling edge of home position at high speed reverse direction → Decelerate to 0 → Search for the rising edge of home position at low speed forward direction → Stop after searching for the falling edge of home position at low speed reverse direction.

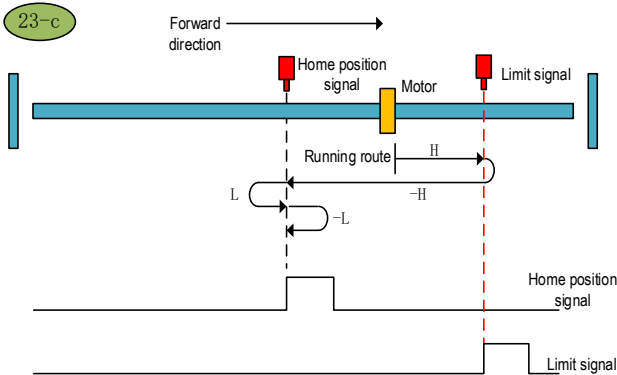

Home position return method 23-c

8.3.24 Home Position Return Method 24

a. Start the home position return → Home position signal OFF → Search for the rising edge of home position at high speed forward direction → Decelerate to 0 → Search for the falling edge of home position at low speed reverse direction → Stop after searching for the rising edge of home position at low speed forward direction.

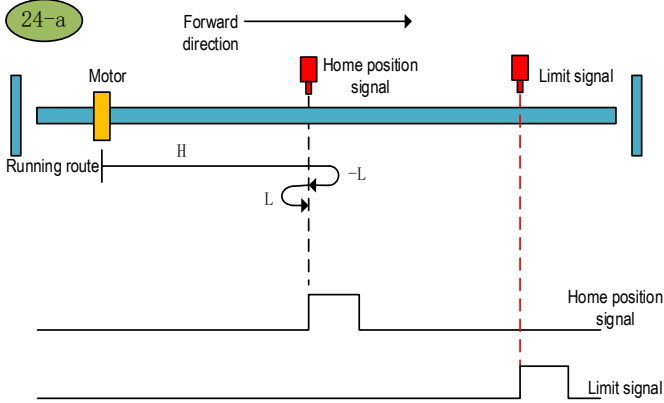

Home position return method 24-a

b. Start the home position return → Home position signal ON → Search for the falling edge of home position at low speed reverse direction → Stop after searching for the rising edge of home position at low speed forward direction.

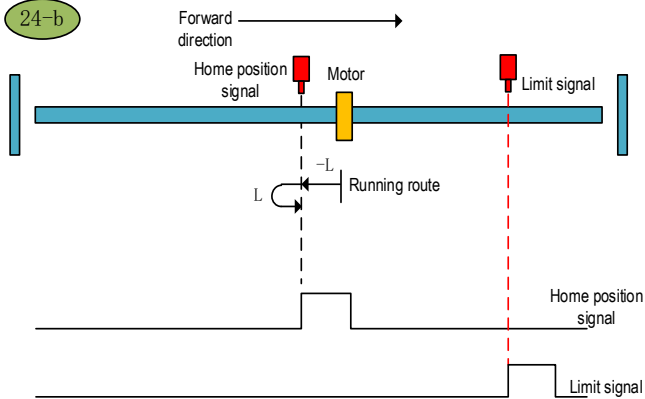

Home position return method 24-b

c. Start the home position return → Home position OFF → Search for the rising edge of home position at high speed forward direction → Touch the forward limit → Search for the falling edge of home position at high speed reverse direction → Decelerate to 0 → Stop after searching for the rising edge of home position at low speed forward direction.

24-c

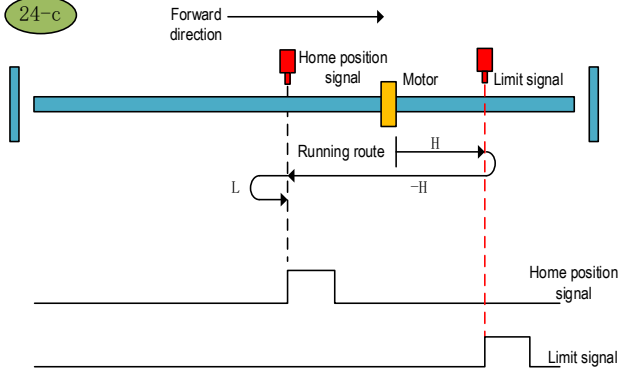

Home position return method 24-c

8.3.25 Home Position Return Method 25

a. Start the home position return → Home position signal OFF → Search for the falling edge of home position at high speed forward direction → Decelerate to 0 → Stop after searching for the rising edge of home position at low speed reverse direction.

25-a

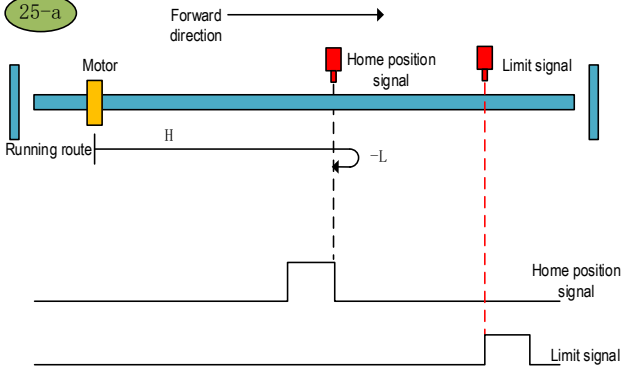

Home position return method 25-a

b. Start the home position return → Home position signal ON → Search for the falling edge of home position at high speed forward direction → Decelerate to 0 → Stop after searching for the rising edge of home position at low speed reverse direction.

25-b

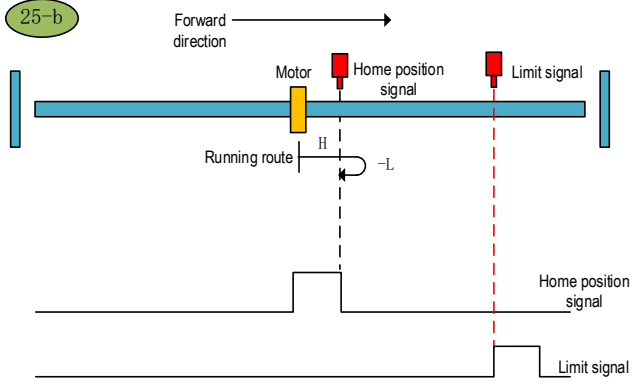

Home position return method 25-b

c. Start the home position return → Home position OFF → Search for the falling edge of home position at high speed forward direction → Touch the forward limit → Search for the rising edge of home position at high speed reverse direction → Decelerate to 0 → Search for the falling edge of home position at low speed forward direction → Stop after searching for the rising edge of home position at low speed reverse direction.

25-c

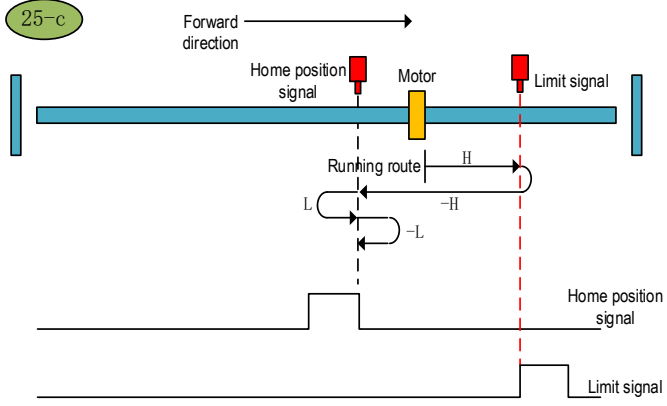

Home position return method 25-c

8.3.26 Home Position Return Method 26

a. Start the home position return → Home position signal OFF → Search for the falling edge of home position at high speed forward direction → Decelerate to 0 → Search for the rising edge of home position at low speed reverse direction → Stop after searching for the falling edge of home position at low speed forward direction.

26-a

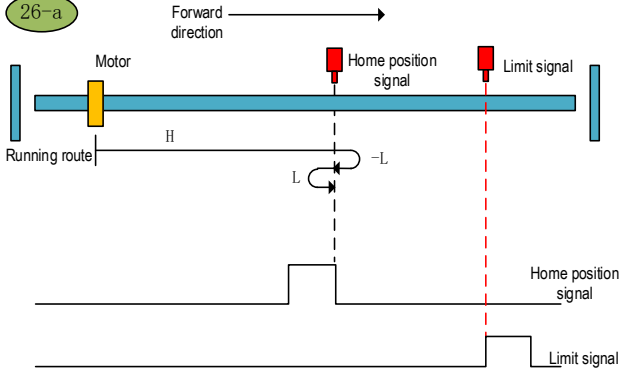

Home position return method 26-a

b. Start the home position return → Home position signal ON → Search for the falling edge of home position at high speed forward direction → Decelerate to 0 → Search for the rising edge of home position at low speed reverse direction → Stop after searching for the falling edge of home position at low speed forward direction.

26-b

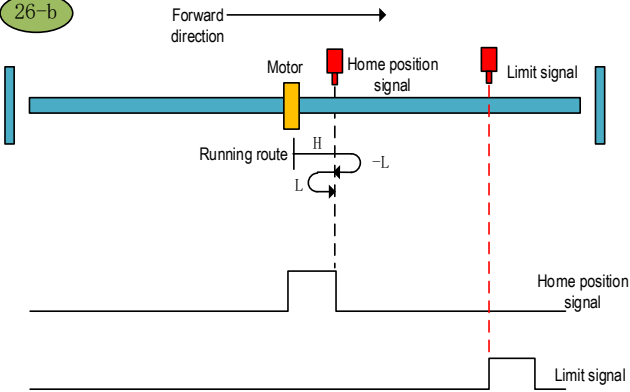

Home position return method 26-b

c. Start the home position return → Home position OFF → Search for the falling edge of home position at high speed forward direction → Touch the forward limit → Search for the rising edge of home position at high speed reverse direction → Decelerate to 0 → Stop after searching for the falling edge of home position at low speed forward direction.

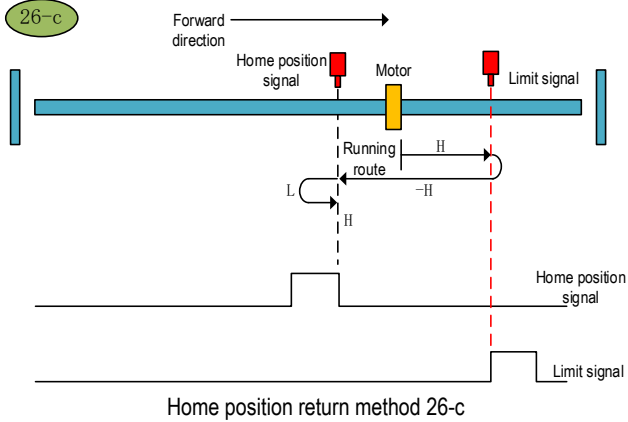

8.3.27 Home Position Return Method 27

a. Start the home position return → Home position signal OFF → Search for the rising edge of home position at high speed reverse direction → Decelerate to 0 → Stop after searching for the falling edge of home position at low speed forward direction.

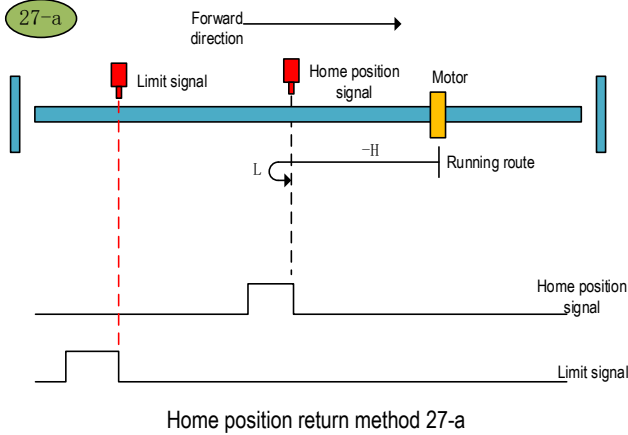

b. Start the home position return → Home position signal ON → Stop after searching for the falling edge of home position at low speed forward direction.

27-b

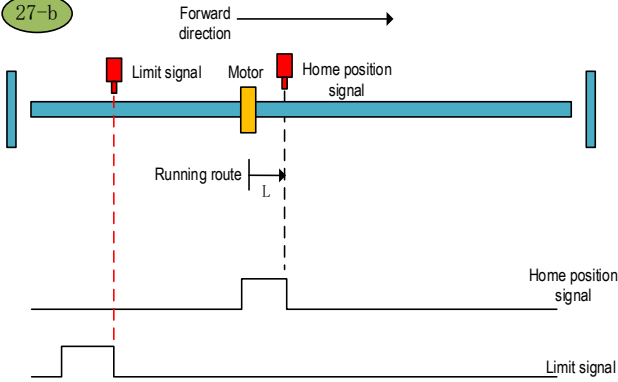

Home position return method 27-b

c. Start the home position return → Home position signal OFF → Search for the rising edge of home position at high speed reverse direction → Touch the reverse limit → Search for the falling edge of home position at high speed forward direction → Decelerate to 0 → Stop after searching for the rising edge of home position at low speed reverse direction.

27-c

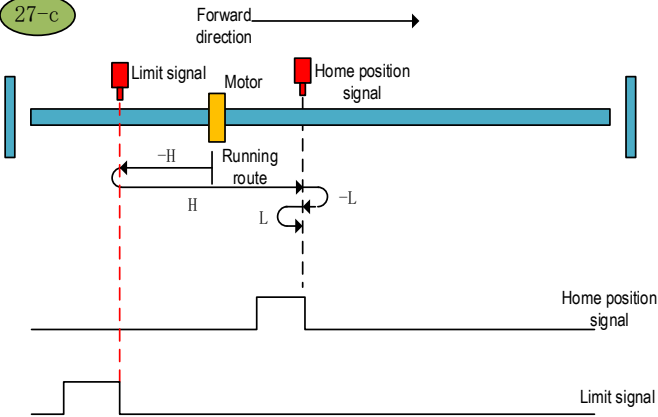

Home position return method 27-c

8.3.28 Home Position Return Method 28

a. Start the home position return → Home position signal OFF → Search for the rising edge of home position at high speed reverse direction → Decelerate to 0 → Search for the falling edge of home position at high speed forward direction → Stop after searching for the rising edge of home position at low speed reverse direction.

28-a

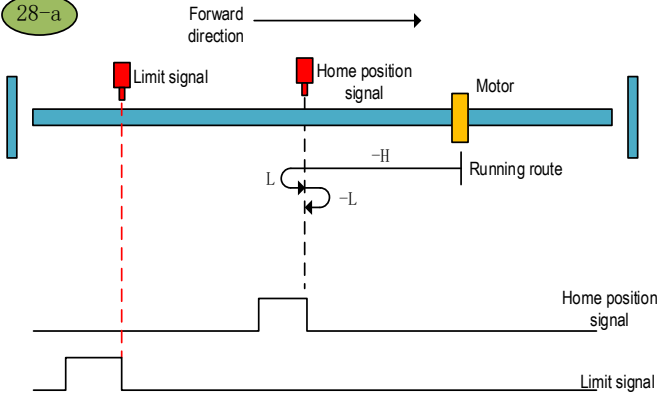

Home position return method 28-a

b. Start the home position return → Home position signal ON → Search for the falling edge of home position at low speed forward direction → Stop after searching for the rising edge of home position at low speed reverse direction.

28-b

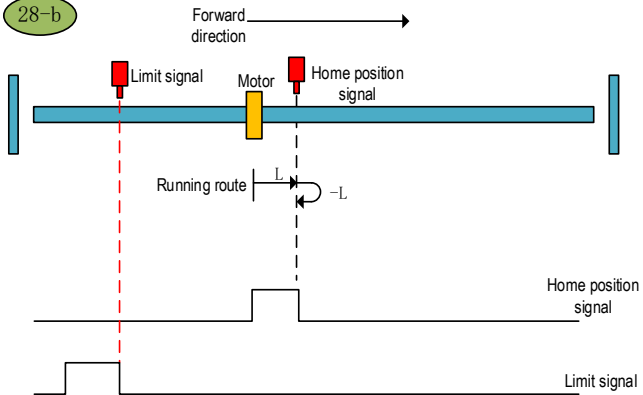

Home position return method 28-b

c. Start the home position return → Home position signal OFF → Search for the rising edge of home position at high speed reverse direction → Touch the reverse limit → Search for the falling edge of home position at high speed forward direction → Decelerate to 0 → Stop after searching for the rising edge of home position at low speed reverse direction.

28-c

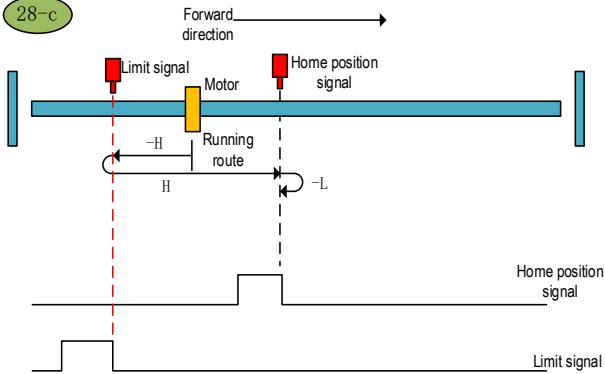

Home position return method 28-c

8.3.29 Home Position Return Method 29 (6098 00h=29)

a. Start the home position return → Home position signal OFF → Search for the falling edge of home position at high speed reverse direction → Decelerate to 0 → Stop after searching for the rising edge of home position at low speed forward direction.

29-a

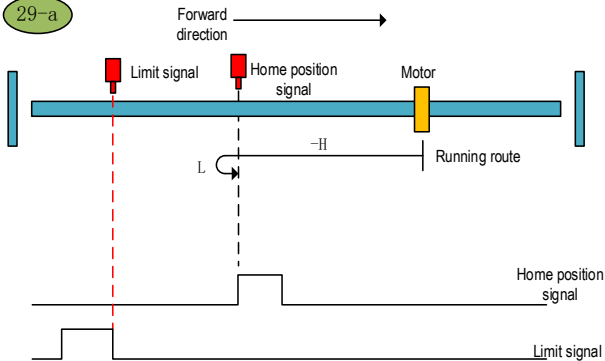

Home position return method 29-a

b. Start the home position return → Home position signal ON → Search for the falling edge of home position at high speed reverse direction → Decelerate to 0 → Stop after searching for the rising edge of home position at low speed forward direction.

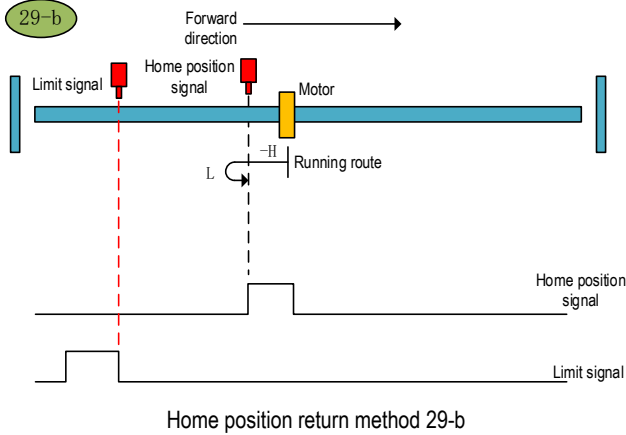

c. Start the home position return → Home position signal OFF → Search for the falling edge of home position at high speed reverse direction → Touch the reverse limit → Search for the rising edge of home position at high speed forward direction → Decelerate to 0 → Search for the falling edge of home position at low speed reverse direction → Stop after searching for the rising edge of home position at low speed forward direction.

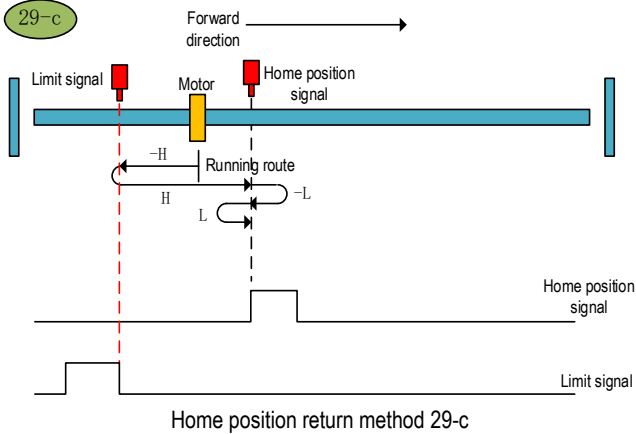

8.3.30 Home Position Return Method 30 (6098 00h=30)

a. Start the home position return → Home position signal OFF → Search for the falling edge of home position at high speed reverse direction → Decelerate to 0 → Search for the rising edge of home position at low speed forward direction → Stop after searching for the falling edge of home position at low speed reverse direction.

30-a

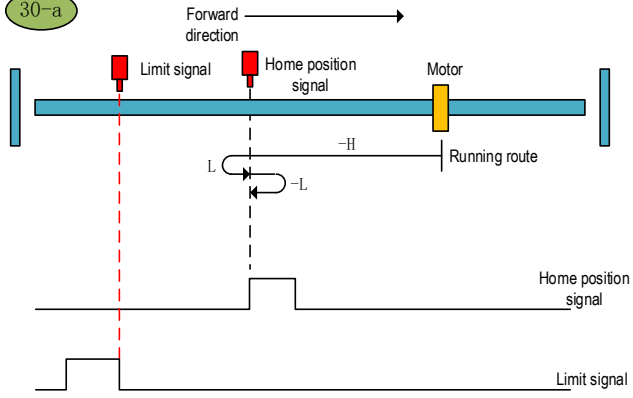

Home position return method 30-a

b. Start the home position return → Home position signal ON → Search for the falling edge of home position at high speed reverse direction → Decelerate to 0 → Search for the rising edge of home position at low speed forward direction → Stop after searching for the falling edge of home position at low speed reverse direction.

30-b

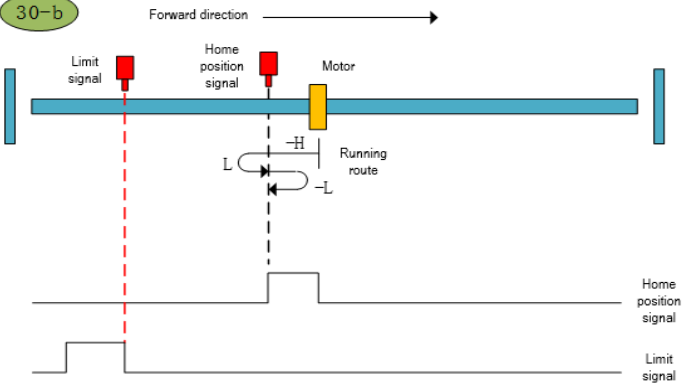

Home position return method 30-b

c. Start the home position return → Home position signal OFF → Search for the falling edge of home position at high speed reverse direction → Touch the reverse limit → Search for the rising edge of home position at high speed forward direction → Decelerate to 0 → Stop after searching for the falling edge of home position at low speed reverse direction.

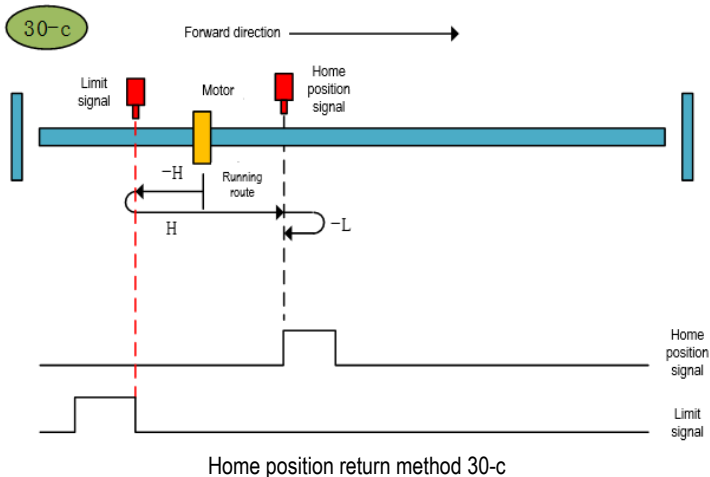

8.3.31 Home Position Return Method 31 (6098 00h=31): Reserved

8.3.32 Home Position Return Method 32 (6098 00h=32): Reserved

8.3.33 Home Position Return Method 33 (6098 00h=33)

Start the home position return → Find the first Z pulse in the reverse direction.

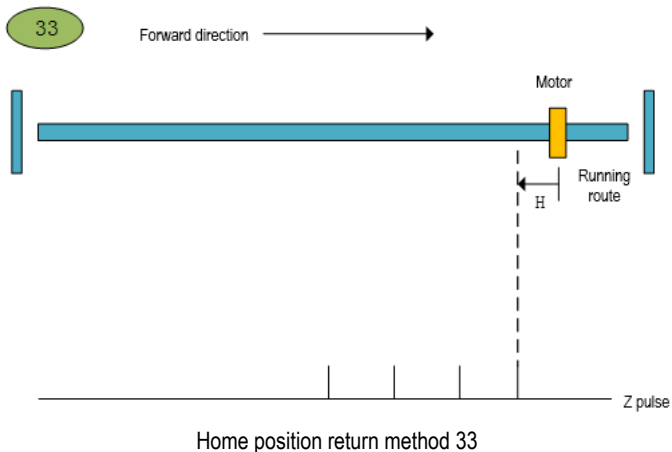

8.3.34 Home Position Return Method 34 (6098 00h=34)

Start the home position return → Find the first Z pulse in the forward direction.

34

Forward direction →

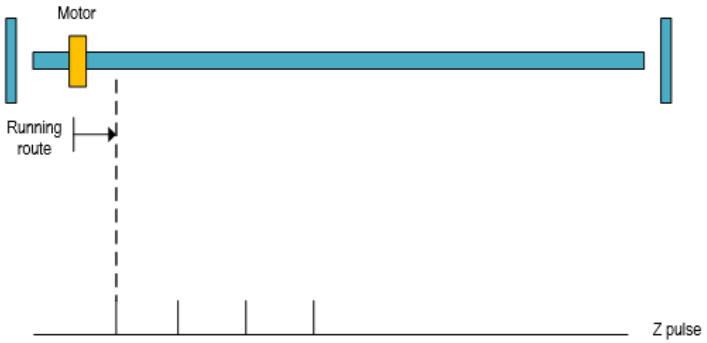

Home position return method 34

9 Internal Position

9.1 The Position Control Function Code Parameter Setting

Pn000	Control mode selection	<input type="radio"/>	Communication address: 0x000
Default: 0	Setting range: 0x0000 ~ 0x000B	Unit: N/A	Control mode: P, S, T

Parameter description: Control mode selection. The position control function is the internal position mode, and the position command is given by the parameter. Before running the position control function, firstly, you need to set the servo drive control mode to position mode.

Pn000	Features
0	Position control mode
not 0 or not 16	Other control mode
16	EtherCAT mode

Pn208	Position command source selection	<input type="radio"/>	Communication address: 0x208
Default: 0	Setting range: 0x0000~ 0x0001	Unit: N/A	Control mode: P

Parameter description: internal and external position command selection. The point position control function is the internal position mode, so before selecting the position control mode, the position command source needs to be set to the internal position mode.

Pn208	Function
0	Position command source selects external pulse input
1	Position command source selects internal position command input

Pn204	Electronic gear ratio molecule	<input type="radio"/>	Communication address: 0x204
Default: 64	Setting range: 1~ 1073741824	Unit: N/A	Control mode: P

Parameter description: electronic gear ratio molecule. The electronic gear ratio of the servo drive is given together with the electronic gear than the denominator.

Pn206	Electronic gear ratio denominator	<input type="radio"/>	Communication address: 0x206
Default: 1	Setting range: 1~ 1073741824	Unit: N/A	Control mode: P

Parameter description: electronic gear ratio denominator. They are given together with the electronic gears.

Note: If the point position control mode is the internal mode, the electronic gear ratio can not be set arbitrarily set the electronic gear ratio, which will cause data overflow, so that the operation error line. When the internal position mode is selected, it is necessary to set the internal position mode. After the electronic gear ratio setting is completed, it is necessary to ensure that the maximum number of command pulses per revolution is less than 2^k (K-bit encoder).

9.2 Position Control Related Function Code

9.2.1 Function Code Description

Position control function, according to the position command, positioning speed, acceleration time, deceleration time, delay time, Pr command type, absolute/incremental/relative position, interrupt function, overlap function, storage function to plan the position trajectory. In addition, the position command trigger can be set through the function code and DI terminal.

9.2.1.1 Position Command Trigger, Select, Stop

Position command trigger, select and stop can be realized in two ways. The first method is to use the external input terminal (DI terminal) to realize the selection, trigger, and stop the position command segment number. The second method uses specific function codes to trigger, select, and stop position commands.

Position command trigger, selection and stop can be realized through DI terminal. The position command trigger is realized by configuring the POS0-POS4 function of the DI terminal. SD700 allows planning 31 internal position commands. Select the position segment to be operated according to the combination of POS0-POS3. Set the selected position segment number to NUM, then the corresponding relationship between POS0-POS4 and the segment number of the position command is:

POS4	POS3	POS2	POS1	POS0	Position segment number NUM
0	0	0	0	0	0
0	0	0	0	1	1
0	0	0	1	0	2
0	0	0	1	1	3
0	0	1	0	0	4
0	0	1	0	1	5
0	0	1	1	0	6
0	0	1	1	1	7
0	1	0	0	0	8
0	1	0	0	1	9
0	1	0	1	0	10
0	1	0	1	1	11

0	1	1	0	0	12
0	1	1	0	1	13
0	1	1	1	0	14
0	1	1	1	1	15
1	0	0	0	0	16
1	0	0	0	1	17
1	0	0	1	0	18
1	0	0	1	1	19
1	0	1	0	0	20
1	0	1	0	1	21
1	0	1	1	0	22
1	0	1	1	1	23
1	1	0	0	0	24
1	1	0	0	1	25
1	1	0	1	0	26
1	1	0	1	1	27
1	1	1	0	0	28
1	1	1	0	1	29
1	1	1	1	0	30
1	1	1	1	1	31
0	0	0	0	0	

The position command trigger is realized through the PosTrig function of the DI terminal. First select the internal position command segment number through DI terminals POS0-POS3, and then use PosTrig to trigger to run. The rising edge of the PosTrig signal indicates that the currently selected position command segment operation is triggered.

Note: Trigger the point with the segment number 0 to perform the home position return operation; the point other than 0 is the normal point.

During the Pr internal position command execution, if you want the Pr position function of the DI terminal to stop immediately, you can stop the operation by the PosStop function of the DI terminal. Using the rising edge of PosStop means immediately stopping the current running position command segment.

POS0- POS3 position command selection, PosStop position command stop, PosTrig position command trigger can be realized by DI terminal, defined as follows:

Position DI function	DI function code number
PosTrig	0x16
POS0	0x17
POS1	0x18
POS2	0x19
POS3	0x1A
POS4	0x1B
PosStop	0x20

Position command triggering, selection, and stop can be implemented by an external DI terminal or

by a specific function code assignment.

When we want to use the position command selection, trigger and stop, we need a lot of DI input terminals. For convenience, the function code mode is added to the position control program for position command selection, triggering and stopping operations.

The setting of the internal position command is related to the function code Pn898. According to the input value of Pn898, it will perform the according Pr command operation. The correspondence between Pn898 and the Pr position command selection, trigger, and stop is shown in the following table:

Pn898	Pr command function
1~31	Pr command segment number, trigger Pr position instruction execution Relative to Trig+PosNum
1000	The Pr command stop. Equivalent to a STOP bit
other	Invalid

In addition to triggering the Pr instruction segment, Pn898 can also display the segment number of the current Pr instruction and whether it is completed. Reading Pn898, if current Pn898 is shown as 10000+PosNum, then the current Pr instruction segment number PosNum of Pr instruction is being executed. If Pn898 displays 20000+PosNum, it means that the current Pr instruction segment number PosNum position instruction has been executed, and can receive the next Pr instruction. The Pn898 function code is defined as shown in the following table:

Pn898	Communication given Pr command segment number	○	Communication address: 0x898
Default: 10000	Setting range: 0x0000 ~ 0xFFFF	Unit: N/A	Control mode: P

Parameter description: Pr position command segment number given by communication. By setting Pn898, the Pr command segment that you want to execute can be given by communication method and keypad mode. If the internal position command mode of Pr is selected while the servo is enabled, when the value of Pn898 is set to between 1 and 31, the corresponding Pr position command segment will be executed. During the execution of the entire Pr internal position command, the value of Pn898 can be read to determine whether the current executing position command segment and whether the current position command segment are executed.

If Pn898 is displayed in the format of 10000+PosNum, it indicates that the instruction segment whose current Pr instruction segment number is PosNum is being executed.

If Pn898 is displayed in the format of 2000+PosNum, it means that the instruction segment whose current Pr instruction segment number is PosNum has been executed, and the next Pr position command segment can be accepted.

Note: When the servo is enabled, after set the point number in Pn898 and then execute it. If the servo is not enabled, Pn898 will always display 20000, and the point operation will not be performed. By setting Pn898 = 1000, the Pr command segment can be stopped by communication.

9.2.2 Position Command Control Parameter Configuration

Position command segment can be divided into a control position command word and the position command pulses two parts.. 31 segment position command segment is defined in the SD700.

Assuming that the position command segment number is POSNUM, the control word of the current position command segment is given by the function code Pn804+POSNUM*4; the current position

command pulse number is given by the function code Pn806+POSNUM*4. By analogy, a total of 31 segment instruction segments are defined from function code Pn804 to Pn87E.

The control word for the position command segment is given by Pn804. The lower 16 bits define the point position control mode, and the higher 16 bits define the point operation parameter selection.

Pn804	Pr 1 control word		○	Communication address: 0x804
Default: 0x 00000000	Setting range: 0x0 ~ 0x80000000	Unit: N/A	Control mode: P	

Parameter description: The lower 16 bits of the internal position command control word are the internal position command trajectory planning control word. Interpolation, overlap, relative / absolute, single-segment / multi-segment / speed / jump of internal position commands can be planned by the lower 16 bits of the internal position command control word. The upper 16 bits define the speed, acceleration, deceleration, and delay time of the Pr position command. The function code from Pn880 to Pn897 defines the acceleration/deceleration time, positioning speed and delay time during the operation of the Pr position command.

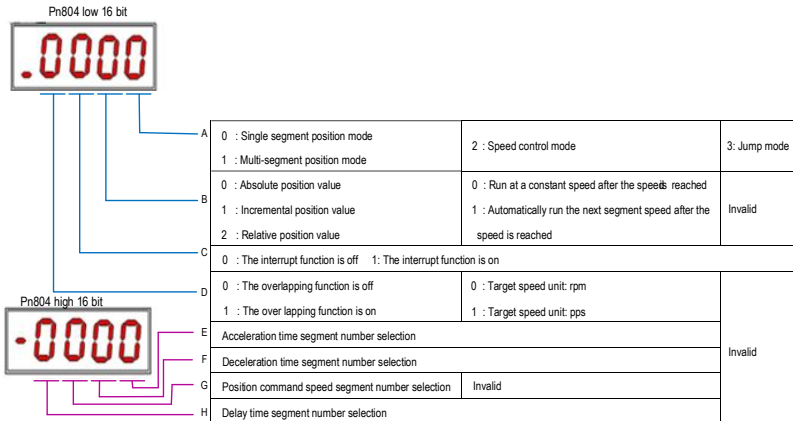

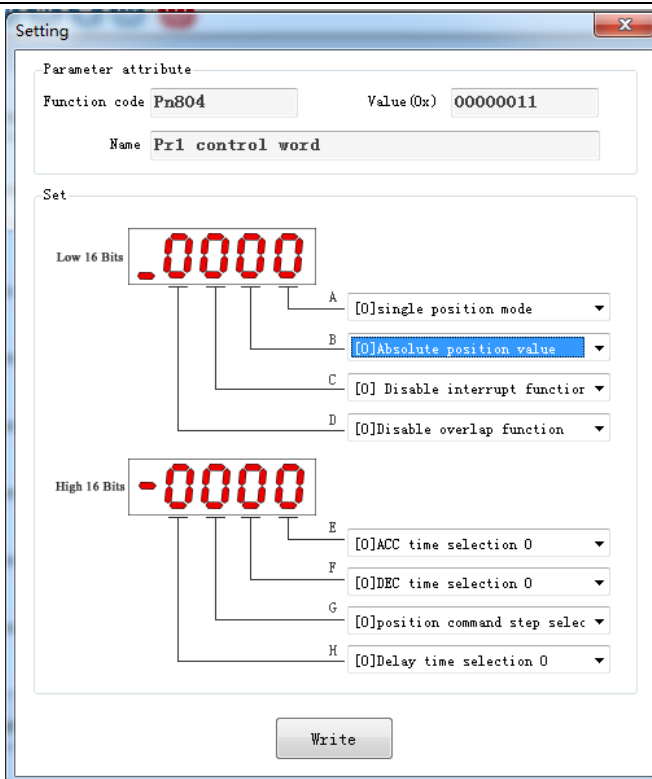

Function code A part function definition: select internal position mode.

A part	Features
0	Single segment position mode
1	Multi-segment position mode
2	Speed control mode
3	Jump mode

Single-segment, multi-segment description:

The single-segment position command indicates that the next position command is no longer executed after the current position command is executed. The multi-segment position command indicates that the next position command is executed after the current position command is executed. If several consecutive position commands are multiple segments, the multi-segment position command is executed continuously. The single-segment / multi-segment position instruction is executed as shown below:

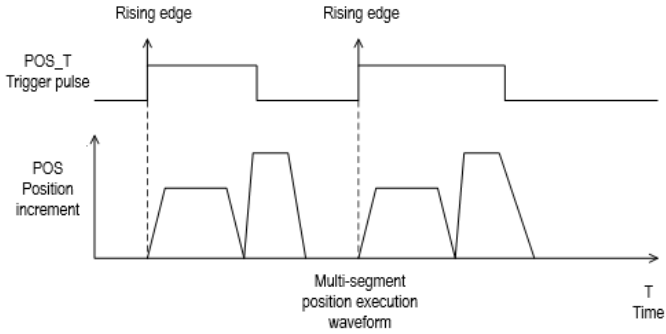
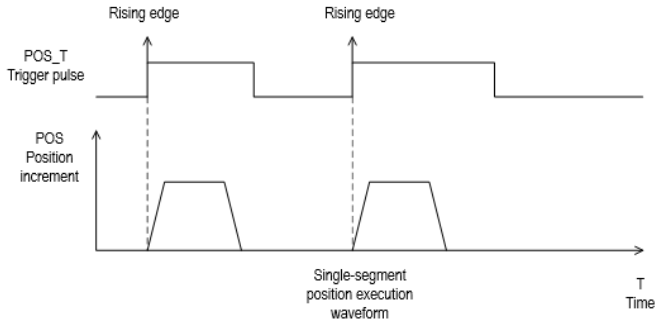

Speed mode description: If the current position command segment is given the speed mode, when the position command is planned, the motor runs at the set speed until the next Pr position command starts.

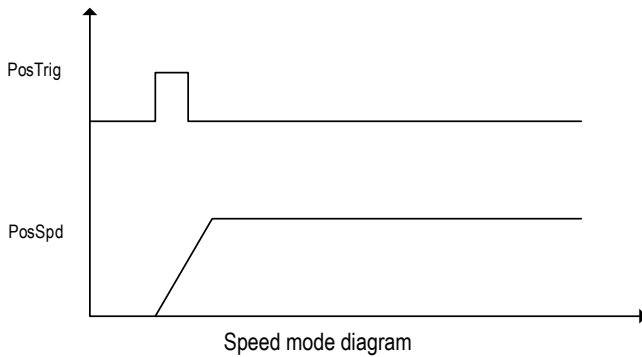

Jump mode description:

If the current position command segment bit jump mode, the current position command segment immediately jumps to the position command segment of the specified segment number, and the position command of the specified segment is executed.

Function code B part function definition: select command mode.

Part B	Single / multi-segment position mode	Speed mode	Jump mode
0	The current position command value is the absolute position value	After the implementation of the current speed does not switch to the next Pr	—
1	The current position command value is the incremental position value	The next segment of Pr is automatically executed after the current speed is executed	—
2	Current position command value is relative position value	—	—

Single segment/ multi segment position mode: Part B of the position command type description:

1 Absolute position command: The motor running target position value is the given position command value.

TargetPos = PosAbs.

2 Relative position command: The motor running target position value is the current actual position value plus the given relative position value.

TargetPos = PosFdb + PosRel.

3 Incremental position command: motor running target position value is the previous position command value plus the current incremental position command value.

TargetPos = PosCmd + PosInc.

Speed mode: Part B function description:

In the speed mode, the B part of the control word indicates whether the next Pr command value is automatically executed after the current speed command is reached. If the B part is 1, the next Pr command value is automatically executed. The next Pr instruction can be a single-segment, multi-segment position command, a speed command, or a jump command. If part B is 0, the motor will continue to run at the speed value given by the current Pr until the next Pr instruction starts execution.

Function code C part function definition: select the interrupt function.

Part C	Position mode	Speed mode	Jump mode
0	Interrupt function is not enabled	Interrupt function is not enabled	Interrupt function is not enabled
1	Interrupt function enable	Interrupt function enable	Interrupt function enable

Interrupt Description: When the interrupt function is enabled, it will switch to the next position command immediately, regardless of whether the current position command is running or not. The

margin of the current position command is accumulated to the next position command for position command planning. If the interrupt function is not enabled, it will switch to the next position value execution only after the current position command is completed. The plug-in function is shown below:

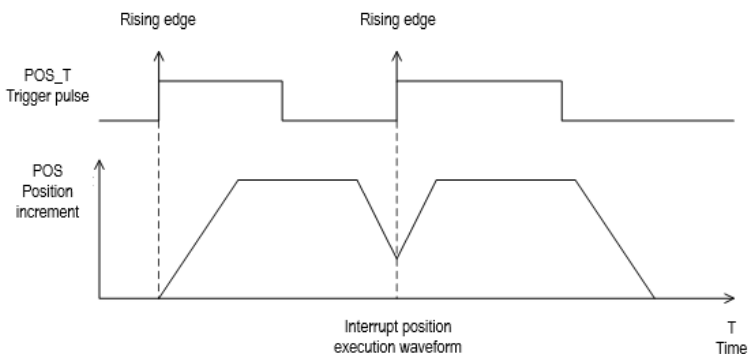

Interrupt operation

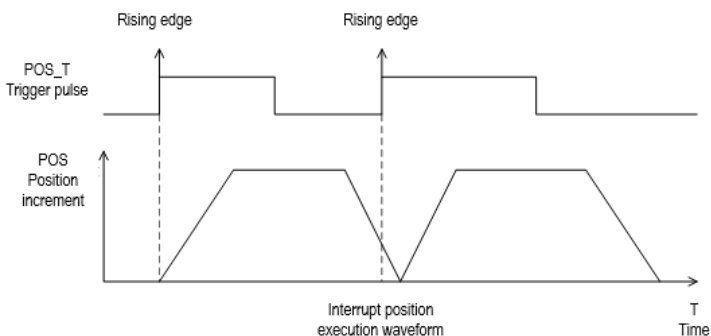

Uninterrupted operation

Note: The interrupt function is valid after the Pr command is set, and the interrupt function is judged when the latter command is triggered.

Function code D part function definition: select overlapping function

Part D	Single / multi-segment position mode	Speed mode	Jump mode
0	Overlap function does not turn on	Target speed unit rpm	—
1	Overlap function on	Target speed unit PPS	—

Position overlap description: After the overlap function is turned on, when the multi-segment position command is executed, when each position command is executed to the deceleration phase, it will not decelerate to 0, and the next position command will be directly planned from the current speed. If the overlap function is not turned on, after the current position command is

executed, decelerate to 0 and then plan the next position command. The overlap function works only in multiple positions, the single-segment position does not work, and the multi-segment position delay time becomes 0 after the overlap function is turned on. The multi-segment position overlap function is shown below:

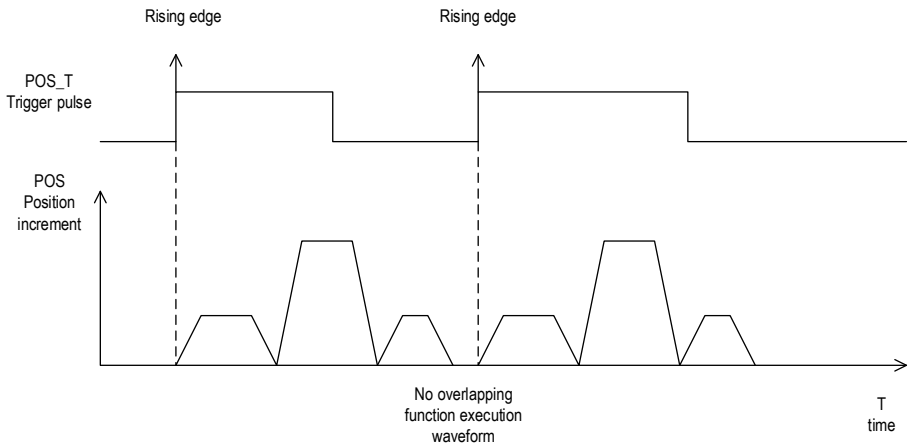
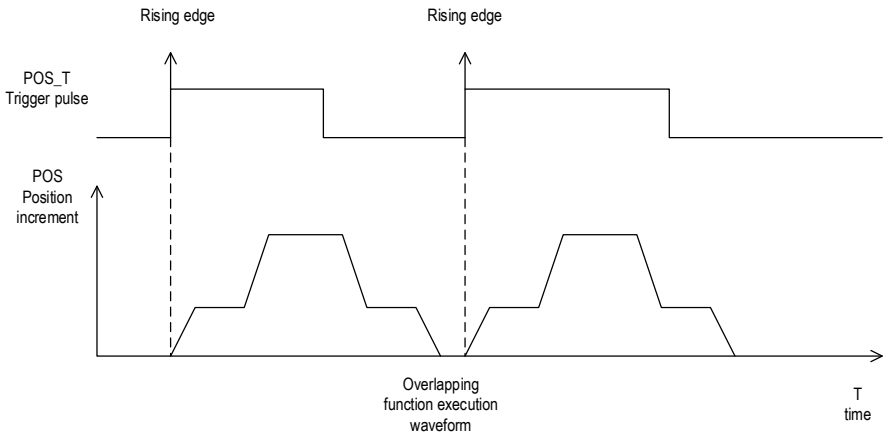

Note: When the overlap occurs, the previous instruction setting takes effect. When the previous instruction runs to the deceleration point, it runs the next instruction.

Note: In speed mode, this bit indicates the speed command unit.

Speed unit description: The speed unit defines whether the speed value given by the current speed command segment is the rpm (how many revolutions per minute) speed value or the PPS (running pulses per second) speed value.

Function code E part function definition: Acceleration time selection.

Part E	Single / multi-segment position mode function	Speed mode	Jump mode
0	Acceleration time selects the time defined by Pn880	Acceleration time selects the time defined by Pn880	Invalid
1	Acceleration time selects the time defined by Pn881	Acceleration time selects the time defined by Pn881	Invalid
2	Acceleration time selects the time defined by Pn882	Acceleration time selects the time defined by Pn882	Invalid
3	Acceleration time selects the time defined by Pn883	Acceleration time selects the time defined by Pn883	Invalid
4	Acceleration time selects the time defined by Pn884	Acceleration time selects the time defined by Pn884	Invalid
5	Acceleration time selects the time defined by Pn885	Acceleration time selects the time defined by Pn885	Invalid
6	Acceleration time selects the time defined by Pn886	Acceleration time selects the time defined by Pn886	Invalid
7	Acceleration time selects the time defined by Pn887	Acceleration time selects the time defined by Pn887	Invalid

Function code F part function definition: Deceleration time selection.

Part F	Single / multi-segment position mode function	Speed mode	Jump mode
0	Deceleration time selects the time defined by Pn880	Deceleration time selects the time defined by Pn880	Invalid
1	Deceleration time selects the time defined by Pn881	Deceleration time selects the time defined by Pn881	Invalid
2	Deceleration time selects the time defined by Pn882	Deceleration time selects the time defined by Pn882	Invalid
3	Deceleration time selects the time defined by Pn883	Deceleration time selects the time defined by Pn883	Invalid
4	Deceleration time selects the time defined by Pn884	Deceleration time selects the time defined by Pn884	Invalid
5	Deceleration time selects the time defined by Pn885	Deceleration time selects the time defined by Pn885	Invalid
6	Deceleration time selects the time defined by Pn886	Deceleration time selects the time defined by Pn886	Invalid
7	Deceleration time selects the time defined by Pn887	Deceleration time selects the time defined by Pn887	Invalid

Function code G part function definition: Running speed selection.

Part G	Single / multi-segment position mode function	Speed mode	Jump mode
--------	---	------------	-----------

0	Speed value selects the value defined by Pn888	Invalid	Invalid
1	Speed value selects the value defined by Pn889	Invalid	Invalid
2	Speed value selects the value defined by Pn88A	Invalid	Invalid
3	Speed value selects the value defined by Pn88B	Invalid	Invalid
4	Speed value selects the value defined by Pn88C	Invalid	Invalid
5	Speed value selects the value defined by Pn88D	Invalid	Invalid
6	Speed value selects the value defined by Pn88E	Invalid	Invalid
7	Speed value selects the value defined by Pn88F	Invalid	Invalid

Function code H part function definition: Delay time selection.

Part G	Single / multi-segment position mode function	Speed mode	Jump mode
0	Delay time selects the value defined by Pn890	Delay time selects the value defined by Pn890	Invalid
1	Delay time selects the value defined by Pn891	Delay time selects the value defined by Pn891	Invalid
2	Delay time selects the value defined by Pn892	Delay time selects the value defined by Pn892	Invalid
3	Delay time selects the value defined by Pn893	Delay time selects the value defined by Pn893	Invalid
4	Delay time selects the value defined by Pn894	Delay time selects the value defined by Pn894	Invalid
5	Delay time selects the value defined by Pn895	Delay time selects the value defined by Pn895	Invalid
6	Delay time selects the value defined by Pn896	Delay time selects the value defined by Pn896	Invalid
7	Delay time selects the value defined by Pn897	Delay time selects the value defined by Pn897	Invalid

9.2.3 Position Command Segment Pulse Given

Assuming the position command segment number is NUM, in the single-segment / multi-segment position mode, the position command pulse number is given by the function code Pn806 +4 *NUM. In speed mode, the given speed value is given by Pn806 +4*NUM.

Pn806	Single / multi-segment position command pulse number	○	Communication address: 0x806
	Speed mode given speed value		

Default: 0	Setting range: - 2 ³¹ ~2 ³¹	Unit: circle	Control mode: P
------------	---	--------------	-----------------

Parameter description: In the single-segment / multi-segment position mode, it is the position command pulse number given. In speed mode, it is the running target speed given.

Note: Pay attention to the speed given unit when the speed value is given in the speed mode, and the speed unit is given by the D part of Pn804.

9.2.4 Position Command Segment Sharing Parameters

The speed, acceleration/deceleration time, and delay time of the Pr position command are common parameters. Each of the Pr position command segments can select one of eight speeds, acceleration/deceleration time, and delay time as the operating parameters of the current position command segment. The shared parameter definition is as follows:

Pn880	Internal multi-segment position acceleration/deceleration time selection 0	<input type="radio"/>	Communication address: 0x880
Default:100	Setting range:0~60000	Unit:N/A	Control mode: P

Parameter description: Internal position command acceleration/deceleration time selection. From the function code Pn880 to the function code Pn887, a total of 8 sets of internal multi-segment position acceleration/deceleration time are defined. Control the actual internal multi-segment position, according to the part E of the position of the control command multi-segment word high 16 bit of , select Pn880 to Pn887 a parameter as an internal position command acceleration time; controlled according to an internal position multistage position The F- part of the upper 16 bits of the word selects one of Pn880 to Pn887 as the deceleration time of the internal multi-segment position command.

Note: When several different position command segments select the same acceleration /deceleration time function code, modify the acceleration/deceleration time value of the corresponding function code, and the acceleration/deceleration time of several position commands will be changed at the same time. Deceleration time setting is from 0rpm to accelerate to rated speed of the motor required.

Pn881	Internal multi-segment position acceleration/deceleration time selection 1	<input type="radio"/>	Communication address: 0x881
Default: 200	Setting range: 0 ~ 60000	Unit: ms	Control mode: P

Same as Pn881

Pn882	Internal multi-segment position acceleration/deceleration time selection 2	<input type="radio"/>	Communication address: 0x882
Default: 300	Setting range: 0 ~ 60000	Unit: ms	Control mode: P

Same as Pn881

Pn883	Internal multi-segment position acceleration/deceleration time selection 3	<input type="radio"/>	Communication address: 0x883
--------------	--	-----------------------	------------------------------

Default: 400	Setting range: 0 ~ 60000	Unit: ms	Control mode: P
--------------	--------------------------	----------	-----------------

Same as Pn881

Pn884	Internal multi-segment position acceleration/deceleration time selection 4	○	Communication address: 0x884
Default: 500	Setting range: 0 ~ 60000	Unit: ms	Control mode: P

Same as Pn881

Pn885	Internal multi-segment position acceleration/deceleration time selection 5	○	Communication address: 0x885
Default: 600	Setting range: 0 ~ 60000	Unit: ms	Control mode: P

Same as Pn881

Pn886	Internal multi-segment position acceleration/deceleration time selection 6	○	Communication address: 0x886
Default: 700	Setting range: 0 ~ 60000	Unit: ms	Control mode: P

Same as Pn881

Pn887	Internal multi-segment position acceleration/deceleration time selection 7	○	Communication address: 0x887
Default: 800	Setting range: 0 ~ 60000	Unit: ms	Control mode: P

Same as Pn881

Pn888	Internal multi-segment position speed value selection 0	○	Communication address: 0x888
Default: 100	Setting range: 0 ~ 6000	Unit: rpm	Control mode: P

Parameter description: Internal multi-segment position command speed selection. From the function code P n888 to P n88F , a total of 8 sets of internal multi-segment position velocity values are provided. When the internal multi-segment position control is actually performed, a set of parameters between Pn888 and Pn88F is selected as the speed reference value for the internal multi-segment position operation according to the value of the F part of the internal multi-segment position control word high 16 bits.

Pn889	Internal multi-segment position speed value selection 1	○	Communication address: 0x889
Default: 200	Setting range: 0 ~ 6000	Unit: rpm	Control mode: P

Same as Pn888

Pn88A	Internal multi-segment position speed value selection 2	○	Communication address: 0x88A
--------------	---	---	------------------------------

Default: 500	Setting range: 0 ~ 6000	Unit: rpm	Control mode: P
--------------	-------------------------	-----------	-----------------

Same as Pn888

Pn88B	Internal multi-segment position speed value selection 3	<input type="radio"/>	Communication address: 0x88B
Default: 1000	Setting range: 0 ~ 6000	Unit: rpm	Control mode: P

Same as Pn888

Pn88C	Internal multi-segment position speed value selection 4	<input type="radio"/>	Communication address: 0x88C
Default: 1500	Setting range: 0 ~ 6000	Unit: rpm	Control mode: P

Same as Pn888

Pn88D	Internal multi-segment position speed value selection 5	<input type="radio"/>	Communication address: 0x88D
Default: 2000	Setting range: 0 ~ 6000	Unit: rpm	Control mode: P

Same as Pn888

Pn88E	Internal multi-segment position speed value selection 6	<input type="radio"/>	Communication address: 0x88E
Default: 2500	Setting range: 0 ~ 6000	Unit: rpm	Control mode: P

Same as Pn888

Pn88F	Internal multi-segment position speed value selection 7	<input type="radio"/>	Communication address: 0x88F
Factory value: 3000	Setting range: 0 ~ 6000	Unit: rpm	Control mode: P

Same as Pn888

Pn890	Internal multi-segment position delay time selection 0	<input type="radio"/>	Communication address: 0x890
Default: 0	Setting range: 0 ~ 60000	Unit: 0.1s	Control mode: P

Parameter description: Internal multi-segment position command delay time selection. From the function code Pn890 to Pn897, a total of 8 sets of internal multi-segment position delay time selection are provided. When the internal multi-segment position control is actually performed, a set of parameters between Pn890 and Pn897 is selected as the internal multi-segment position between the two-point position command according to the value of the D portion of the internal multi-segment position control word high 16 bits. Interval time (unit: 0.1s, delay time range is 0s ~ 6000s).

Note: For the position command, the delay time is the calculated after the position command pulse is sent. For the speed mode, the delay time is calculated after the speed value reaches the set target speed.

Pn891	Internal multi-segment position delay time selection 1	<input type="radio"/>	Communication address: 0x891
Default: 1	Setting range: 0 ~ 60000	Unit: 0.1s	Control mode: P

Same as Pn890.

Pn892	Internal multi-segment position delay time selection 2	<input type="radio"/>	Communication address : 0x892
Default: 5	Setting range: 0 ~ 60000	Unit: 0.1s	Control mode: P

Same as Pn890.

Pn893	Internal multi-segment position delay time selection 3	<input type="radio"/>	Communication address: 0x893
Default: 10	Setting range: 0 ~ 60000	Unit: 0.1s	Control mode: P

Same as Pn890.

Pn894	Internal multi-segment position delay time selection 4	<input type="radio"/>	Communication address: 0x894
Default : 100	Setting range : 0 ~ 60000	Unit: 0.1s	Control mode: P

Same as Pn890.

Pn895	Internal multi-segment position delay time selection 5	<input type="radio"/>	Communication address: 0x895
Default: 1000	Setting range: 0 ~ 60000	Unit: 0.1s	Control mode: P

Same as Pn890.

Pn896	Internal multi-segment position delay time selection 6	<input type="radio"/>	Communication address: 0x896
Factory value: 5000	Setting range: 0 ~ 60000	Unit: 0.1s	Control mode: P

Same as Pn890.

Pn897	Internal multi-segment position delay time selection 7	<input type="radio"/>	Communication address: 0x897
Default: 10000	Setting range: 0 ~ 60000	Unit : 0.1s	Control mode: P

Same as Pn890.

9.3 The Point Function Operating Parameters

The point function plans the corresponding position trajectory according to the set speed, acceleration/deceleration time, delay time, and target position value. The operation parameters of the first segment of the command segment are taken as an example for description.

9.3.1 Position Command

In position mode, the number of position command pulses for point position control is given by $Pn806 + POSNUM \times 4$. The position command unit is the user unit. The position command pulse number is given by the electronic gear ratio $Pn204$ and $Pn206$.

In position mode, the target position value can be an incremental position value, a relative position value, and an absolute position value.

The incremental position command is mainly used for the operation mode in which the target position is clear and the target position value is independent of the actual position. The reference point for the incremental position is the position command value. The incremental position operation mode is as shown below:

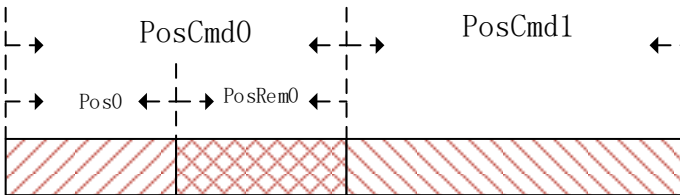

As shown in the figure above, the first position command setting value is $PosCmd0$. After the pulse of $Pos0$ is run, the operation ends and the remaining $PosRem0$ pulses are not completed. If the second incremental position command $PosCmd1$ is inserted at this time, the total number of pulses of the second position command operation is $PosCmd1 + PosRem0$. That is, the second incremental position value $PosCmd1$ is based on the first position position command $PosCmd0$, and the final running position value is $PosCmd0 + PosCmd1$.

The relative position command is referenced to the actual position value. The position command value of the latter segment is used as a reference point for the actual position value at the time of operation, and the target position value is calculated. The relative position operation mode is as shown below:

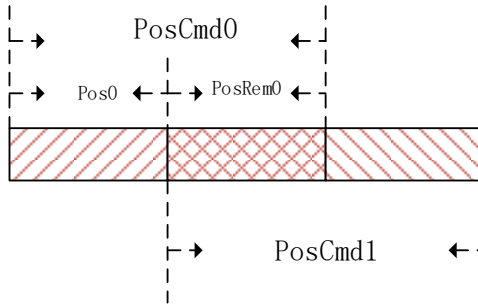

As shown in the figure above, the first position command setting value is PosCmd0. After the pulse of Pos0 is run, the operation ends and the remaining PosRem0 pulses are not completed. If the second relative position command PosCmd1 is inserted at this time, the total number of pulses of the second position command operation is PosCmd1. That is, the second relative position value PosCmd1 is the reference point of the actual position Pos0, and the final running position value is Pos0 + PosCmd1.

The absolute position command is referenced to the absolute position value relative to zero. Regardless of the current actual position value, whether or not there is a pulse margin has not been completed. The absolute position command values are all distances that must be taken relative to absolute zero. As shown below:

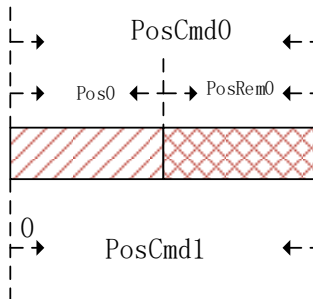

As shown in the figure above, the first position command setting value is PosCmd0. After the pulse of Pos0 is run, the operation ends and the remaining PosRem0 pulses are not completed. If the second absolute position command PosCmd1 is inserted at this time, the total number of pulses of the second position command operation is PosCmd1- Pos0. That is, the second absolute position value PosCmd1 is the absolute position 0 bit reference point, and the final running position value is PosCmd1.

9.3.2 Acceleration and Deceleration Time

Position control function during operation, during the operation of the point position control function, the acceleration and deceleration base value is calculated based on the maximum speed of the motor. . For example, setting the acceleration time of the motor running for 100ms means that when the motor is running from 0rpm to the maximum speed, it needs to accelerate from 0rpm to the maximum speed in 100ms.

The point position control function sets the maximum acceleration/deceleration time to 60000ms and the minimum value to 0ms. In the point position control position trajectory planning, if the relationship between the acceleration/deceleration time, speed and position value is unreasonable and cannot be operated according to the set acceleration/deceleration time, the point position control program will be based on the current speed and target position value, recalculate the acceleration/deceleration time of the operation, and run according to the re-planned acceleration/deceleration time, as shown in the following figure:

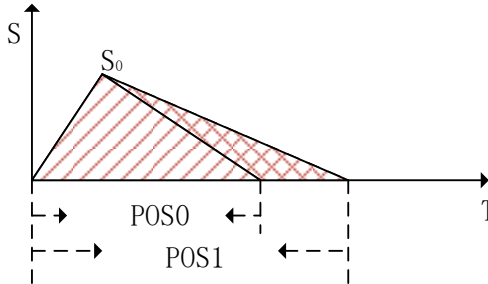

As shown in the figure above, when the motor runs to S_0 according to the set acceleration time, if it continues to decelerate according to the set deceleration time, the final running position value of the motor will reach the distance indicated by $Pos1$. In the point position control position command planning, the set target position value is $Pos0$. In order to ensure that the final running position of the motor reaches the position of $Pos0$ accurately, it is necessary to re-plan the deceleration time to ensure that the motor finally runs to the $Pos0$ position.

9.3.3 Point Position Control Speed and Delay Time

The point position control speed reference is divided into two types: position control mode and speed mode.

For the position mode, when the position command is planned, the desired running speed is given by the speed selected by the G part of the 16 bit a high word of the Pr command segment control word. This speed value can only be given a positive speed value. When planning according to the position command, the positive and negative values of the target position are used to set the forward and reverse of the desired speed.

For speed mode, the target speed value is given by $P\ n806 + POSNUM * 4$ when the Pr is running. If you want to run in reverse in speed mode, you can set the value of $P\ n806 + POSNUM * 4$ to a negative value.

During the point position control operation, whether the target speed in the speed mode or the desired speed in the position mode, the given maximum speed value is allowed to be 6000 rpm, given speed is limit to 6000 rpm. . In the speed mode, when the given speed unit is PPS, the maximum value of 6 000 rpm will be converted to the limit of the PPS unit.

For non-interrupted and non-overlapping operations, the delay time of the point position control is valid. After completing a current Pr instruction, how long it takes to execute the next Pr instruction.

The unit of delay time is 0.1s. For the speed mode, the delay time is defined as how long it takes for the motor running speed command to reach the set speed command value before the next Pr command can be run.

When the interrupt operation is performed, the next Pr instruction will be executed immediately, so the delay time can be interrupted in the interrupt mode. That is, when the current Pr instruction is not completed, or the execution completion has not reached the delay time, the next Pr instruction can be executed immediately by the interrupt function.

When the operation is overlapped, the set delay time is automatically ignored, and the next position command is planned immediately when the deceleration point is reached.

9.4 The Interrupt Function

In the point position control function, the interrupt function can interrupt the previous position command operation and immediately execute the newly inserted position command. Run according to the newly inserted position command target position. Incremental position into a position command, the absolute and relative positions of three forms, not different from each other between a position command interrupt, having different operating modes.

9.4.1 Incremental Position Interrupt Position Command

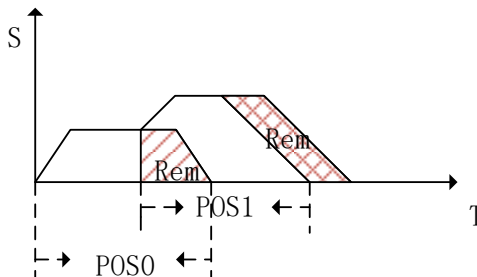

As shown in the figure above, the incremental position interrupt position command is running. For first position command segment, the target position is Pos0, during operation it is interrupted by position command of the second segment. Now the pulses number of the first segment after interrupting remains Rem. The second position command is an incremental position command, and the target position value is Pos1. After the second position command interpolates the first position command, it immediately runs according to the set speed of the second position command. Because the second position command is the incremental position, the second position command runs the total pulse value Pos0+Pos1. Equivalent to, as shown above in the picture, the first segment position command margin is transferred to the second segment position to execute.

9.4.2 Equivalent Position Command Insertion Position Command

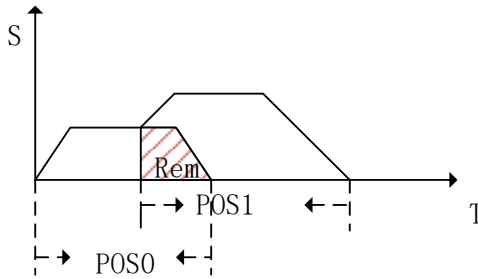

As shown in the figure above, it is operation of the relative position insertion position. For the first position command, the target position is Pos0, it is interrupted by the second position command during running, and the remaining pulse is Rem. The second position command is a relative position command, the target position is Pos1. After the second position command is interrupted, it immediately runs at the target speed of the second position and runs the pulse number Pos1 relative to the actual position value. The total pulse number Pos0+ Pos1-Rem that has passed after the end of the two-stage operation. That is, when the relative position is interrupted, the position margin value of the previous segment is ignored, and a position is directly run based on the current actual position. As shown in the figure above, the position equivalent to the Rem area is ignored.

9.4.3 Absolute Position Interrupt Position Command

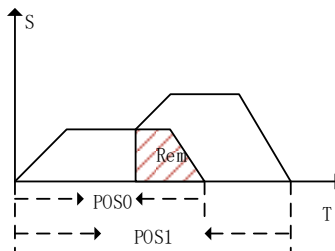

As shown in the figure above, it is absolute position interrupt position. For the first position command, the target position is Pos0, it is interrupted by the second position command during running, and the remaining pulse is Rem. The second position command is an absolute position command and the target position is Pos1. After the second segment position command is interrupted, it is immediately run according to the target speed of the second segment position, run into an absolute position Pos1. The total pulse number is Pos1 after the two position operation. That is, after the insertion, the previous position command value is ignored, and the absolute position command value is directly operated according to the insertion.

Pn864 function code definition

Function code A part function definition:

A part	Function
0~9	Point buffer depth

Function code E part function definition:

E part	Function
0	Jogging is invalid
1	Forward jog
2	Reverse jog

The maximum point buffer depth is 10-level. When the buffer depth is set to 0, the point buffer function is turned off.

Note: In the point position control program, it is allowed to store up to 10 Pr instruction segments. Pr instruction segments exceeding 10 segments will overwrite the previously stored instruction segments. The stored Pr command segment can be a single-segment position command or a segment head command of a multi-segment position command.

The previous Pr position command is a single-segment position command. During the operation, the new position command is triggered through the PosTrig function, and the newly triggered position command is temporarily stored. After the previous Pr command is completed, the stored position command is read for operation. The schematic diagram of the single-segment storage function is shown in the figure below:

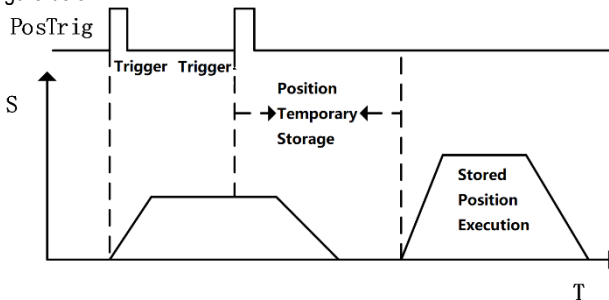

Single-segment storage diagram

As shown in the figure above, during the operation of a single position command, another Pr command is triggered. If the interrupt is not set for another Pr instruction, you need to wait for the current Pr instruction to complete before executing. From the triggering to the execution of the second Pr instruction, the second Pr instruction is temporarily stored in the position instruction storage Buffer.

9.4.4 Multi-segment Storage Function

When the previous Pr command is a multi-segment Pr command, if a new position command is inserted, and the newly inserted position command is not set to interrupt, it will be temporarily stored.

When the execution of the position segment currently being executed by the multi segment PR instruction is completed, the stored position instruction segment is executed immediately. The remaining unexecuted position command segments of multiple positions will be discarded and no longer executed. The multi-segment storage function is shown in the following figure:

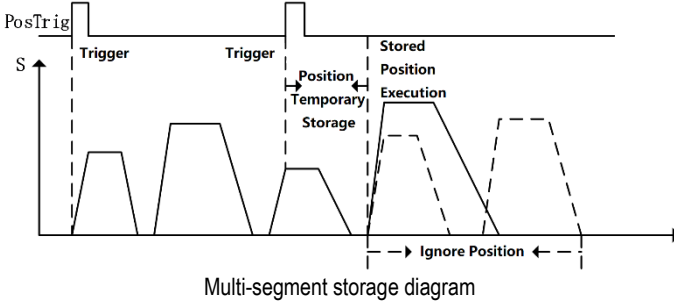

As shown in the figure above, the first position command is a multi-segment position command, and there are 5 position command segments. During operation, when the multi-segment position command is executed to the third position, a new position command value is inserted through an external trigger. The command does not set the interrupt function for the newly inserted position, so when the execution of the third position instruction of the previous multi segment position instruction series is completed, the newly inserted position instruction value is executed. The fourth and fifth position command values of the multi-segment position command series will no longer be executed.

9.4.5 Overlapping Storage Function

When the previous position command is set to overlap the function, during the operation of the position command, if a new position command is inserted through an external trigger, and under the situation that there is no interrupt function in the new position command, when the previous position command execute to the deceleration point position, start to read the stored position command value, and plan the stored position command value in an overlapping manner. The overlapping storage function is shown in the following figure:

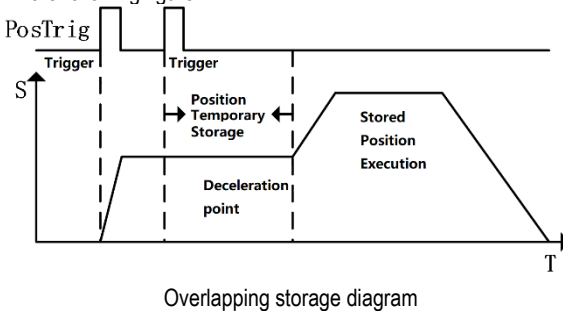

As shown in the figure above, the first position command sets the overlap function, and the new position command is inserted by external trigger during operation. When the new position command is not set to interrupt, the newly received position command is temporarily stored. At the first position when the command runs to the deceleration point position, it is judged that the first position command overlap function is turned on. At this time, the value of the temporarily stored position command is

directly read, and the execution process of the temporarily stored position command is planned in an overlapping manner.

9.4.6 Interrupt Storage Function

The position command storage function of internal multi-segment position control allows storing up to 3 position command values. If there is currently a stored position command being executed, and there is still a stored position command that has not been executed, use an external trigger to insert a new one position command. The new position command sets the interrupt function, it will immediately interrupt the executing position command segment, and execute the newly inserted position command value. After the newly inserted position command is executed, read the stored ones that have not been executed. Position command value, continue to execute. Interrupt storage function as shown below:

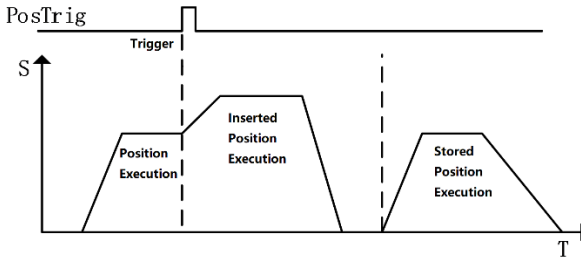

Interrupt storage diagram

As shown in the figure above, during the execution of the first position command, there is a stored position waiting to be executed. When the first position is executed, a new position command is inserted through an external trigger, and the newly inserted position command enables the interrupt function and executes the newly inserted position command immediately. After the newly inserted position command is executed, execute the stored position command value.

9.5 Overlapping Function

When the multi-segment position is continuously running, the transition of the multi-segment position command speed can be realized by setting the multi-segment position overlapping function. The function of the overlapping function is to directly read the operating parameters (running position, speed, acceleration/deceleration time, etc.) of the next section when the first position is moved to the position of the deceleration point, and directly plan the next section of the running trajectory from the deceleration point, thereby achieving a smooth transition of the two-segment position trajectory. The overlay function is shown below:

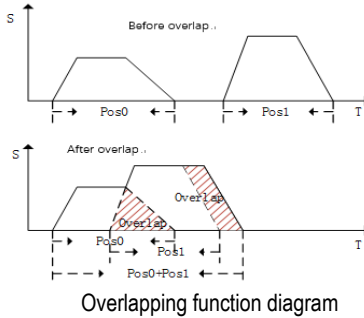

As shown in the figure above, when multiple positions overlap is operating, when it reaches the deceleration point of the previous position, the operating parameters of the next position command are directly read, and the running trajectory of the next position command is planned on the basis of the current speed to realize the smoothing of the two positions transition. In the process of overlapping operation, the remaining pulse value that is not completed in the previous position command will be compensated to run on the next position command, and there will be no pulse loss problem.

9.6 Stop Function

During the operation of internal multi-segment position control, PosStop can be used to trigger the current running position command to stop. PosStop can be triggered by the rising edge of DI terminal by configuring external DI terminal 0x20; it can also be triggered by means of communication, setting Pn898=1000, PosStop function is realized. After stopping the currently running position command through the stop function, the remaining pulse value of the current position that is not running will be temporarily stored in the program. Before starting to run the next Pr command program, you need to consider the remaining pulse. The stop function is shown in the figure below:

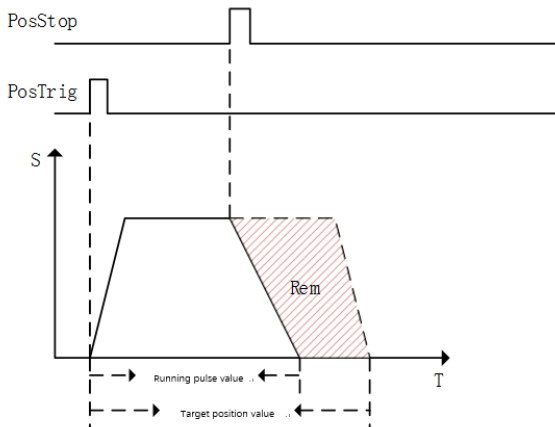

Stop function diagram

As shown in the figure above, the current running position command value is stopped by PosStop

function during position command operation. After the stop command is triggered, the motor decelerates from the current speed to 0 according to the 500ms deceleration time. After the motor stops, the remaining pulse value of the current position will not clear.

Before starting the next Preposition command planning, the current position command pulse needs to be processed. If you want to clear the remaining amount of the current position command pulse, you can clear the remaining pulse by sending a relative position command with a relative position of 0; if you want to change the current position The remaining pulse of the command is completed, and the remaining pulse can be run by sending an incremental position command with an incremental position of 0; if the next position command is an absolute position command, the current remaining pulse has no effect on the operation of the absolute position command.

9.7 Jump Function

In the internal multi-segment position control program, the Pr command section allowed to be set is a jump command. When a certain section of the Pr command section is set as a jump command, when the current stage is executed, it will jump to Pr command section, immediately jump to the specified Pr command section for execution. The value of the Pr command jumped to can be a single-segment position command, the first value of a multi-segment position command, speed command, etc. During the jump process, if Jump command jump in its own situation, the jump error occurs, and the servo drive automatically stops. The schematic diagram of the jump function is shown below:

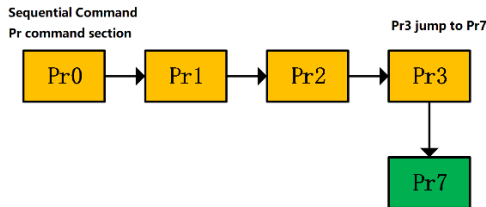

Jump function diagram

As shown in the figure above, the current position command is executed in sequence. When executed to the Pr3 command segment, the Pr3 command segment jumps to the Pr7 specified segment, and immediately execute the position command defined by Pr7 command value. Jump can be realized by sequential execution or by external trigger. Jump command can enable interrupt function, if the triggered jump function is enabled Interrupt function, interrupt the currently executing Pr command, and immediately jump to the specified Pr command section; If the triggered jump function does not enable interrupt, the triggered jump command will be temporarily stored and wait for the current Pr Jump after the execution of the specified segment is completed. The interrupt jump function diagram is shown below:

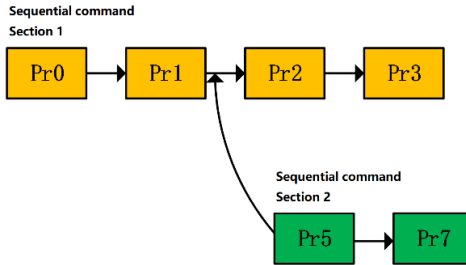

Interrupt jump function

As shown in the figure above, there are two command segments 1 and 2 that are executed sequentially. When multiple segments of command1 are currently being executed, by external trigger segment 5, and segment 5 is specified by Pr as a jump command, interrupt function is enabled, and jump the target command segment number is 7. The currently running multi-segment command ends and immediately starts to execute the position command value of Pr command segment 7.

In addition to jumping to any available Pr command segment number, the jump function can also implement multi-segment position command loop execution through the jump function, as shown in the following figure:

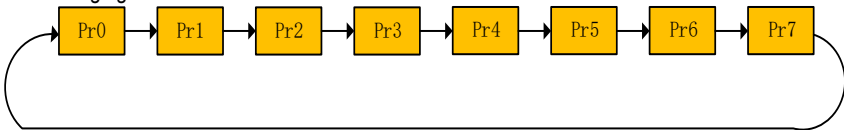

Multi-section position command loop

As shown in the figure above, when the Pr command of the last paragraph of the multi-segment position command is set as a jump command, from the last Pr command to the Pr command at the beginning, so that multiple Pr commands can be executed in a loop.

9.8 Jog Function

The jog function can be realized by means of communication or internal jog operation via external terminals. The jog function must be operated when the servo is enabled. In the process of jog execution, the point function is no longer executed. The point can be executed normally after the jog execution is completed.

The internal jog function code is shown in the following table:

Pn500	Jog speed	○	Communication address: 0x500
Default: 500	Setting range: 0~1000	Unit: rpm	Control mode: P,S

Parameter description: Jog speed setting. Unit rpm

Pn505	Jog acceleration and deceleration time	○	Communication address: 0x505
Default: 100	Setting range: 2~10000	Unit: ms	Control mode: P,S

Parameter description: In jog mode, acceleration and deceleration time setting.

Pn506	Jog delay time	○	Communication address: 0x505
Default: 100	Setting range: 0~10000	Unit: ms	Control mode: P,S

Parameter description: After the point reaches the set speed, the delay time.

9.8.1 Jog Operation of External Terminals

External terminal jog, terminal function definition is shown in the following table:

Terminal function definition	Description
0x1E	Forward jog
0x1F	Reverse jog

The external terminal input and jog execution satisfy the following logic table:

Forward jog 0x1E terminal status	Reverse jog 0x1E terminal status	Jog function description
OFF	OFF	Not executed jog
ON	OFF	Forward jog
OFF	ON	Reverse jog
ON	ON	Not executed jog

As shown in the above table, the relationship between Forward Jog and Reverse Jog is “exclusive OR”. That is, if only one terminal of Reverse Jog is valid, the Jog can be executed normally.

9.8.2 Communication Jog

Communication Jog is realized by the high 16 bits of function code Pn89F.

Value	Function
0	Jog invalid
1	Forward jog
2	Reverse jog

As shown in the above table, when the function code Pn89F is 0, the Jog function is turned off; when the function code is 1, Forward Jog is performed; when the given value is 2, Reverse Jog is performed.

Note: Regardless of the external terminal Jog or the communication Jog, you need to set the servo enable first.

10 Function Code Instructions

10.1 Pn0 Group Basic Control Related Parameters

Function code	Parameter	Range	Default	Unit	Communication address	When enabled
Pn000	Control mode selection	0 ~ 11	0	-	0x0000	After restart
	0-Position mode: The position of the motor is controlled by the pulse sequence position command. The position is controlled by the number of input pulses, and the speed is controlled by the frequency of the input pulse that is used in the place where positioning action is required. 1-1-Analog speed: The servo motor speed is controlled by the analog voltage speed command. 2-2-Torque Mode: The output torque of the servo motor is controlled by the analog voltage torque command/internal torque command which is used to output the necessary torque (pressing action, etc.). 3-3-Internal speed: The speed is controlled by three internally set speeds set in the servo unit. When this control method is selected, no analog voltage is required. 4-4-Internal Speed <-> Analog Speed: Switch control mode via ON/OFF of switch/SPD-A and /SPD-B. 5-5-Internal Speed <-> Position Mode : Switch control mode via ON/OFF of switch/SPD-A and /SPD-B. 6-6-Internal Speed <-> Torque Mode: Switch control mode via ON/OFF of switch/SPD-A and /SPD-B. 7-7-Position Mode <-> Analog Speed: ON/OFF switching control mode by (C-SEL) signal switching. 8-8-Position mode <-> Torque mode:ON/OFF switching control mode by (C-SEL) signal switching. 9-Torque mode <-> Analog speed: ON/OFF switching control mode by (C-SEL) signal switching. 10-Analog speed <-> Speed mode for zero function: When controlling speed, zero fixed function can be used. 11-Position mode <-> Position mode when command pulse inhibit: The command pulse inhibit function can be used when controlling the position. See "selection of hybrid control mode" for specific switching sequence. 16-EtherCAT mode (-EA model, this parameter defaults to 16).					
Pn001	Internal enable	0 ~ 1	0	-	0x001	Immediately
	0-Enable OFF. 1-Enable ON.					
Pn002	Motor rotation direction selection	0 ~ 1	0	-	0x0002	After restart
	Facing motor end: 0-Counterclockwise is forward. 1-Clockwise direction is forward.					
Pn003	Default monitoring parameters	0x0 ~ 0xff	0xff	-	0x0003	Immediately
	Set the monitoring parameters that are displayed by default after power-on. The setting values are detailed in the monitoring parameters. 0xff indicates that the monitoring parameters are not displayed and the system status is displayed. Note: The alarm is displayed first when the alarm is displayed. The setting parameter cannot be displayed normally.					
Pn004	Servo OFF and stop method selection when type 1 alarm occurs	0 ~ 2	0	-	0x0004	After restart

	<p>0- Stop motor by DB. 1- Stop the motor through the DB and then release the DB. 2- Do not use DB to keep the motor free. Note: DB (Dynamic Brake) is an emergency stop function. If the servo motor is started or stopped by ON/OFF power supply or servo ON in the state that the command is input, the DB circuit will frequently operate, which may cause the internal components of the servo unit to deteriorate. Please execute start and stop of the servo motor with speed input command or position command.</p>					
Pn005	Second type alarm stop method selection of servo generation	0x00 ~ 0x01	0		0x0005	After restart
	<p>0- Zero speed stop: Set the speed command to "0" and perform a quick stop. 1- Same as Pn004 stop method.</p>					
Pn006	Override warning checkout selection	0 ~ 1	0		0x0006	After restart
	<p>0-No overtravel warning when limit is checked. 1-Overtravel warning is detected when the limit is checked.</p>					
Pn007	Stopping method selection at servo overtravel (OT)	0 ~ 2	0		0x0007	After restart
	<p>Set the stop mode and status after stop when servo overtravel occurs: 0- Same as Pn004 stop method. 1- Use the torque set by Pn053 as the maximum value, and enter the locked state after decelerating to stop. 2- Use the torque set by Pn053 as the maximum value, enter the free state after decelerating to stop.</p>					
Pn008	Servo lock time after electromagnetic brake holding	0 ~ 50	0	0ms	0x0008	Immediately
	<p>When the servo motor is enabled but not running(stop state) and the brake (/BK) signal and the servo ON (/S-ON) signal are off at the same time, setting this parameter can change the time from the brake (/BK) signal OFF to the actual non-power input status of the motor. Note: The brake delay time is slightly different. When this parameter is set, the motor can be prevented from the slight moving by the weight or the external force of the vertical-axis mechanical movement.</p>					
Pn009	Electromagnetic brake holding time delay	10 ~ 100	50	0ms	0x0009	Immediately
	<p>The servo motor won't be powered when the Servo OFF/Alarm/Main circuit OFF occur during the rotation. By setting this parameter and Pn010 (any one is met), the output timing of the brake signal (/BK) OFF can be adjusted. Note: The relevant logic is described in "Keep brake action".</p>					
Pn010	Electromagnetic brake brake delay release speed	0 ~ 10000	100	rpm	0x0010	Immediately
	<p>See the description of "Electromagnetic brake brake delay" for details.</p>					
Pn012	External regenerative resistor power	0 ~ 65535	0	10W	0x0012	Immediately
	<p>When connecting an external regenerative resistor, the regenerative resistor power should be set to a value that matches the allowable capacity of the connected external regenerative resistor. The setting differs depending on the cooling condition of the external regenerative resistor. Note: Refer to "Setting the regenerative resistor" for details.</p>					
Pn013	External regenerative resistor	0 ~ 65535	0	Ω	0x0013	Immediately
	<p>When connecting an external regenerative resistor, the regenerative resistor value should be set to the value matching the connected external regenerative resistor. Note: The minimum regenerative resistance of each power section could be different. Please refer to "Set regenerative resistor" for details. Otherwise, the internal components of the servo unit may be damaged.</p>					

Pn015	Overload warning value	1 ~ 100	20	%	0x0015	After restart
	Setting this parameter can change the overload warning detection time. Note: The overload alarm detection time is detailed in "Overload alarm".					
Pn016	Motor overload detection base current derating setting	10 ~ 100	100	%	0x0016	After restart
	This parameter can change the motor current threshold for calculating the overload alarm, which can shorten the overload alarm detection time. Note: This value is invalid when the motor current is rated above 200%.					
Pn030	Reserved	0 ~ 65535	0	-	0x0030	Immediately
Pn031	Parameter modification operation lock	0 ~ 1	0	-	0x0031	After restart
	0-Allow panel parameters modification. 1-Prohibit panel parameters modification.					
Pn040	Method to use absolute encoder	0 ~ 1	0	-	0x0040	After restart
	0-Use an absolute encoder as an absolute encoder: If the motor is an absolute multi-turn encoder, setting this parameter to 0 can use the multi-turn absolute function. 1-Use an absolute encoder as an incremental encoder: When used as an incremental encoder, the position won't be recorded when power-off and warning or alarm, corresponding to multiple revolutions, won't happen either when the battery is undervoltage or the drive is de-energized.					
Pn041	Absolute encoder battery alarm/warning selection	0 ~ 1	0	-	0x0041	After restart
	0- Set the low battery voltage as a fault: Monitor the battery status within 4 ~ 9 seconds after the driver is powered on / reset, and the undervoltage alarm (Er.830) will be reported when the undervoltage. Over time will not be detected. 1- Set the low battery voltage as a warning: Undervoltage (below 3V) will be reported as an under voltage alarm (Al.930). It will always monitor the battery voltage and can be self-recovery, enable is out of restriction.					

Function code	Parameter	Range	Default	Unit	Communication address	When enabled
Pn044	Full closed loop application related selection	0 ~ 51	1	—	0x0045	After restart
	0: Encoder pulse frequency division output, grating ruler power supply is valid, and grating ruler signal is not filtered. 1: Pulse output, grating ruler power supply is valid, and grating ruler signal is not filtered. 2: Encoder pulse frequency division output, grating ruler power supply is invalid, and grating ruler signal is not filtered. 3: Pulse output, the grating ruler power supply is invalid, and the grating ruler signal is not filtered. 4: Encoder pulse frequency division output, grating ruler power supply is valid, 0MHz ~ 4MHz filtering. 16: Grating ruler pulse output, grating ruler power supply is valid, 0MHz ~ 4MHz filtering. 18: Encoder pulse frequency division output, grating ruler power supply is invalid, 0MHz ~ 4MHz filtering. 19: Grating ruler pulse output, grating ruler power supply is invalid, 0MHz ~ 4MHz filtering. 32: Encoder pulse frequency division output, grating ruler power supply is effective, 0MHz ~ 1MHz filtering. 33: Grating ruler pulse output, grating ruler power supply is effective, 0MHz ~ 1MHz filtering. 34: Encoder pulse frequency division output, grating ruler power supply invalid,					

	<p>0MHz ~ 1MHz filtering. 35: Grating ruler pulse output, grating ruler power supply is invalid, 0MHz ~ 1MHz filtering. 48: Encoder pulse frequency division output, grating ruler power supply is effective, 0MHz ~ 500kHz filtering. 49: Grating ruler pulse output, grating ruler power supply is effective, 0MHz ~ 500kHz filtering. 50: Encoder pulse frequency division output, grating ruler power supply invalid, 0MHz ~ 500kHz filtering 51: Grating ruler pulse output, grating ruler power supply invalid, 0MHz ~ 500kHz filtering. 51: Grating ruler pulse output, grating ruler power supply is invalid, 0MHz ~ 500MHz filtering.</p>					
Pn045	Under-voltage function selection	0~2	1	—	0x0045	After restart
	<p>0 - No Detection of main circuit drop warning. 1 - Detect main circuit drop warning. 2 - Detect main circuit drop warning and perform torque limit. The relevant torque limit is matched with Pn046/Pn047. For details, refer to "Torque limit when main circuit voltage drops".</p>					
Pn046	Torque limit when main circuit voltage drops	0~100	50	%	0x0046	Immediately
	<p>According to the under voltage warning, it will impose the torque limit inside the servo unit. For details, see the "Torque limit when under voltage" instruction.</p>					
Pn047	Torque limit release time when main circuit voltage drops	0~1000	100	ms	0x0047	Immediately
	<p>After the under-voltage warning signal releases, the torque limit value is controlled within the servo unit according to the setting time. For details, see "Torque limit when the main circuit under-voltage".</p>					
Pn050	Torque limit setting	0~4	1	—	0x0050	Immediately
	<p>0- Analog torque (torque mode is invalid). 1- Maximum torque limit 1. 2- Maximum torque limit 1 when forward running; maximum torque limit 2 when reverse running. 3- Maximum torque limit 1 when the "Torque Limit Switching" switch is OFF while Maximum torque limit 2 when it's ON. 4- Limit by the torque command(valid when in torque mode).</p>					
Pn051	Maximum torque limit 1	0~500	500	%	0x0051	Immediately
Pn052	Maximum torque limit 2	0~500	500	%	0x0052	Immediately
Pn053	Emergency stop torque	0~800	800	%	0x0053	Immediately
	<p>The torque when set the motor to deceleration stop.</p>					
Pn061	Panel parameter display selection	0x00~0x01	1	—	0x0061	After restart
	<p>0 - Only display setting parameters. 1 - Show all parameters.</p>					
Pn070	Encoder frequency division pulses	16~4194304	2048	-	0x0070	After restart
	<p>The number of pulses per cycle from the encoder is divided by frequency in accordance with the set value of this parameter. Please set it according to the system specifications of the machine and host device. Note: The set value is the number of A/B quadrature output pulses in one turn. The setting of the number of encoder division pulses will be limited due to the resolution of the encoder. For details, see the "Division pulses output setting" instruction.</p>					
Pn072	Frequency division output inversion	0~1	0	-	0x0072	After restart

	A/B pulse phase sequence selection. 0- Don't negate the pulse output: When forward run, B is ahead of A. 1- Negate the pulse output: When forward run, A is ahead of B.					
Pn080	Local communication address	0x00~ 0x7F	1	—	0x0080	After restart
	During RS-485 communication, this parameter is the 485 communication station number, and during CANopen communication, this parameter is the CANopen slave station number.					
Pn081	485 communication baud rate selection	0~4	1	—	0x0081	After restart
	0bps-9600bps 1bps-19200bps 2bps-38400bps 3bps-57600bps 4bps-115200bps					
Pn082	485 communication verification method	0~5	1	—	0x0082	After restart
	0-No check (N,8,1) 1-Even check (E,8,1) 2-Odd check (O,8,1) 3-No check (N,8,2) 4-Even Check (E,8,2) 5-Odd Check (O,8,2)					
Pn083	CANopen communication baud rate selection	0~6	4	-	0x0083	After restart
	0: 20kbps 1: 50kbps 2: 100kbps 3: 125kbps 4: 250kbps 5: 500kbps 6: 1000kbps					
Pn085	Communication data storage EEPROM	0x0~ 0xFFFF	0x1	-	0x0085	Immediately
	Bit0: 0: Store data to EEPROM. 1: Do not store data to EEPROM. Bit1: 0: During power on and start, the value Bit0 of Pn085 is forced to be 1. 1: During power on and start, the value Bit0 of Pn085 is not forced to be 1. Panel keypad operation setting: 00: Modify the data, power off and store it in EEPROM. After servo restart, Pn085 changes to 01. After connecting the upper computer, 00 is displayed. Disconnect the upper computer and power on again. The panel displays Pn085 as 01 again (Data is not stored in EEPROM when power on, but is stored in EEPROM when power off).					
Pn086	Communication address mapping function selection	0~1	0	-	0x0086	Immediately
	0:Close 1:On					
Pn087	Mapping source address 1	0x0000~ 0xFFFF	0x110	-	0x0087	Immediately
Pn088	Mapping destination address 1	0x0000~ 0xFFFF	0x410	-	0x0088	Immediately
Pn089	Mapping source address 2	0x0000~ 0xFFFF	0x201	-	0x0089	Immediately
Pn08A	Mapping destination address 2	0x0000~ 0xFFFF	0x304	-	0x008A	Immediately
Pn08B	Encoder over temperature alarm threshold (°C)	0~255	80	°C	0x008B	After restart
	The over temperature alarm value of Nikon encoder is fixed at 90°C. and Pn08b has no effect on the change of over temperature alarm value of Nikon encoder. There is no encoder over temperature alarm for Tamagawa encoder below 80 (including) flange. For encoder that cannot detect over temperature alarm, pn08b will be automatically written as 0 in the program; The encoder over temperature alarm will					

	be valid for tamogawa encoder above 130 (including) flange only when bit4 of Pn08c must equal to 1, and Pn08b is written into encoder EEPROM, otherwise it will not be executed (Pn08b = 0, turn off over temperature alarm function).					
Pn08C	Encoder alarm detection selection	0x00 ~ 0x11	0x00	-	0x008C	After restart
	Only when bit4 of Pn08c must equal to 1, and Pn08b is written into encoder EEPROM, or it will not be executed.					

10.2 Pn1 Group Gain Parameters

Function code	Parameter	Range	Default	Unit	Communication address	When enabled
Pn100	Rotary inertia ratio	0 ~ 20000	100	%	0x0100	Immediately
	Rotary inertia ratio = converted load inertia of motor shaft / rotor rotary inertia of servo motor *100%.					
Pn101	First speed gain	1 ~2000	40.0	Hz	0x0101	Immediately
	It becomes a delay element of the outer position loop when the response of the speed loop is low, so overshoot or vibration of the speed command occurs. In the range where the mechanical system does not vibrate, the larger the value is set, the more stable the servo system becomes and the better the responsiveness will be.					
Pn102	First speed integration time constant	0.15 ~ 512	20.00	ms	0x0102	Immediately
	In order to respond to small input, the speed loop contains integral elements. Since this integral element is a delay factor for the servo system, when the time parameter is set too large, overshoot may occur, or the positioning time may be extended meanwhile resulting in poor responsiveness.					
Pn103	First position gain	1 ~2000	40.0	1/s	0x0103	Immediately
	The position loop response is determined by the position loop gain. The higher the setting of the position loop gain is, the higher the responsiveness and the shorter the positioning time will be. The position loop gain cannot be increased beyond the rigidity of the mechanical system. If you want to increase the position loop gain to a larger value, the rigidity of the machine must be increased.					
Pn104	First torque command filter	0 ~ 655.35	1.00	ms	0x0104	Immediately
	Adjusting the parameters of the torque command filter may eliminate the machine vibration caused by the servo drive. The smaller the value is, the better the responsiveness can be. However, the conditions are restricted by the machine conditions.					
Pn105	Second speed gain	1 ~2000	40.0	Hz	0x0105	Immediately
	See Pn101					
Pn106	Second speed integration time constant	0.15 ~ 512	20.00	ms	0x0106	Immediately
	See Pn102					
Pn107	Second position gain	1 ~2000	40.0	1/s	0x0107	Immediately
	See Pn103					
Pn108	Second torque command filter	0 ~ 655.35	1.00	ms	0x0108	Immediately
	See Pn104					

Pn110	Gain switching mode selection	0x00~ 0x01	0	—	0x0110	Immediately
	<p>The gain switching function includes two methods, "Manual gain switching" using an external input signal and "Automatic gain switching" automatically switch. By using the gain switching function, gain can be increased and positioning time can be shortened during the positioning time. When the motor is stopped, reduce gain and suppress vibration.</p> <p>0- Manual gain switch by using the external input signal (G-SEL). 1- When the automatic switching condition is met (Pn111), it automatically switches from the first gain to the second gain; otherwise, it switches back to the first gain.</p>					
Pn111	Gain automatic switching condition of position control	0x00~ 0x05	0	—	0x0111	Immediately
	<p>Set the conditions for automatic gain switching: 0-Positioning completion signal ON. 1-Positioning completion signal OFF. 2-Positioning proximity signal ON. 3-Positioning proximity signal OFF. 4-Position command is 0 after filtering and pulse input is OFF. 5-Position command pulse input is ON. If the conditions are met, then switch to the second gain, otherwise switch to the first gain.</p>					
Pn112	Gain switching transition time 1	0~ 65535	0	ms	0x0112	Immediately
	Starting from the time when the switching condition has been established, after the waiting time, change the gain of the 1 st position loop to the gain of the 2 nd position loop in a straight line within the switching transition time.					
Pn113	Gain switching transition time 2	0~ 65535	0	ms	0x0113	Immediately
	Starting from the time when the switching condition has been established, after the waiting time, change the gain of the 2 nd position loop to the gain of the 1 st position loop in a straight line within the switching transition time.					
Pn114	Gain switching waiting time 1	0~ 65535	0	ms	0x0114	Immediately
	It refers to the time when the switching conditions the 1 st gain to the 2 nd gain is established and the switching really starts.					
Pn115	Gain switching waiting time 2	0~ 65535	0	ms	0x0115	Immediately
	It refers to the time when the switching condition of the 2 nd gain to the 1 st gain is established and the switching really starts.					
Pn121	Speed feedforward gain	0~100	0	%	0x0121	Immediately
	Speed feedforward is a function to shorten the positioning time. This function is effective when position control. Note: position overshoot will occur when the feedforward command is too large. Please set it appropriately while observing the response.					
Pn120	Position integral time constant	0.0~ 5000.0	0.0	ms	0x0120	Immediately
Pn122	Speed feedforward filter time	0~64	0.00	ms	0x0122	Immediately
	Speed feedforward low-pass filter time constant can slow position overshoot and torque jump caused by feedforward.					
Pn123	Use V-REF as speed feedforward selection	0x00~ 0x01	0	—	0x0123	After restart
	Speed feedforward is a function to shorten the positioning time. It is possible to select speed feed forward via external analog V-REF. 0-None.					

	1- Use V-REF as speed feed forward input.					
Pn124	Speed/position control selection (T-REF assignment)	0~1	0	—	0x0124	After restart
	Torque feedforward is a function to shorten the positioning time. Torque feedforward can be selected by external analog T-REF. 0-None. 1- Use T-REF as a torque feed forward input.					
Pn125	Time constant of speed feedback filtering	0.0~655.35	0.0	ms	0x0124	After restart
Pn126	Velocity feedback moving average filter time constant	0x0000~0x0014	0	125us	0x0124	After restart
Pn130	Speed loop control method (PI/IP)	0~1	0	—	0x0130	After restart
	0-PI control. 1-IP control.					
Pn131	Speed loop P-PI switching condition selection	0x00 0x04	0	—	0x0131	Immediately
	This is a function that automatically switches P control and PI control. Through setting the switching condition by this parameter and meeting the corresponding switching condition can suppress overshoot during acceleration and deceleration and shorten the settling time. 0- Conditioned by internal torque command. 1- Conditioned by speed instruction. 2- Conditioned by acceleration. 3- Conditioned by position deviation pulse. 4- No mode switch function.					
Pn132	Speed loop P-PI switching condition (torque command)	0~800	200	%	0x0132	Immediately
	When the torque command exceeds the torque set by this parameter, the speed loop will be switched to P control, otherwise PI control.					
Pn133	Speed loop P-PI switching condition (speed command)	0~10000	0	rpm	0x0133	Immediately
	When the speed command exceeds the speed set by this parameter, the speed loop will be switched to P control, otherwise PI control.					
Pn134	Speed loop P-PI switching conditions (acceleration)	0~30000	0	rpm/s	0x0134	Immediately
	When the speed command exceeds the acceleration set by this parameter, the speed loop will be switched to P control, otherwise PI control.					
Pn135	Speed loop P-PI switching conditions (position deviation)	0~10000	0	command unit	0x0135	Immediately
	When the position deviation exceeds the value set by this parameter, the speed loop will be switched to P control, otherwise PI control.					
Pn136	The speed loop P/PI switching condition (line) (speed)	0~10000	0	mm/s	0x0136	Immediately
Pn137	Speed loop P/PI switching condition	0~30000	0	mm/s ²	0x0137	Immediately

	(straight line) (acceleration)					
Pn140	IF suppression control options	0x00~ 0x11	0x0010	—	0x0140	Immediately
	The IF suppression control function effectively suppresses the continuous vibration of about 100 to 1000 Hz that occurs when the control gain is increased. 0x1#: Automatic setting of IF suppression frequency through intelligent setting and bandwidth setting. 0x0#: Not set by intelligent setting, bandwidth setting, only manual setting. 0x#: IF suppression frequency setting is valid. 0x#0: IF suppression frequency setting is invalid.					
Pn141	Inertial modification of IF vibration suppression	1~1000	100	%	0x0141	Immediately
Pn142	IF suppression frequency	1~3000	100.0	Hz	0x0142	Immediately
	Set IF vibration frequency value.					
Pn143	IF vibration suppression attenuation gain	0~300	0	%	0x0143	Immediately
	Increasing this parameter can increase the vibration suppression effect. However, if the setting is too large, the vibration may be increased. When confirming the vibration suppression effect, simultaneously gradually increase the setting value by each 10% in the range of 0% to 200%. If the vibration suppression effect is still not achieved after reaching 200%, please stop the setting and reduce the control gain appropriately.					
Pn150	Notch filter 1 automatic adjustment selection	0x00~ 0x01	1	—	0x0150	Immediately
	0 - Automatic adjustment without auxiliary functions. 1 - Automatic adjustment through auxiliary functions.					
Pn151	Notch filter 2 automatic adjustment selection	0x00~ 0x01	1	—	0x0151	Immediately
	0 - Automatic adjustment without auxiliary functions. 1 - Automatic adjustment through auxiliary functions.					
Pn152	Automatic notch resonance detection sensitivity	1~200	100	%	0x0152	Immediately
	It's used to set the sensitivity for automatically detecting the resonant frequency. The smaller the value is set, the more sensitive it will be for resonance, the easier it is to detect vibration, and the smaller it is, the more likely it is to falsely detect the resonance frequency.					
Pn153	Notch filter 1 frequency	50~ 5000	5000	Hz	0x0153	Immediately
	Set the frequency of the first notch filter that suppresses resonance. When this parameter is set to 5000, the function of the notch filter is invalid. Note: Do not set the notch filter frequency close to the response frequency of the speed loop. At least this frequency should be set to more than 4 times of the speed loop gain, otherwise it may affect the overall performance of the system.					
Pn154	Notch filter 1Q value	0.5~10	0.70	-	0x0154	Immediately
	The Q value of the notch filter refers to the setting value of the filter frequency width related to the notch filter frequency. The width of the recess varies with the Q value of the notch filter, and the larger the Q value of the notch filter is set, the more sunk and the narrower the width of the filter frequency will be.					
Pn155	Notch filter 1 depth	0~1	0.000	-	0x0155	Immediately
	The notch filter depth refers to the setting of the filter frequency depth related to the notch filter frequency. The depth of the recess varies with the depth of the notch filter.					

	The smaller the notch filter depth value is, the deeper the depression and the higher the vibration suppression effect will be. But setting it too small will increase the vibration.					
Pn156	Notch filter 2 frequency	50~5000	5000	Hz	0x0156	Immediately
	Set the frequency of the second notch filter that suppresses resonance. When this parameter is set to 5000, the function of the notch filter is invalid. Note: Do not set the notch filter frequency close to the response frequency of the speed loop. At least this frequency should be set to more than 4 times of the speed loop gain, otherwise it may affect the overall performance of the system.					
Pn157	Notch filter 2Q value	0.5~10	0.70	-	0x0157	Immediately
	The Q value of the notch filter refers to the setting value of the filter frequency width related to the notch filter frequency. The width of the recess varies with the Q value of the notch filter, and the larger the Q value of the notch filter is set, the more sunk and the narrower the width of the filter frequency will be.					
Pn158	Notch filter 2 depth	0~1	0.000	-	0x0158	Immediately
	The notch filter depth refers to the setting of the filter frequency depth related to the notch filter frequency. The depth of the recess varies with the depth of the notch filter. The smaller the notch filter depth value is, the deeper the depression and the higher the vibration suppression effect will be. But setting it too small will increase the vibration.					
Pn160	Disturbance compensation function selection	0x00~0x01	0	—	0x0160	Immediately
	0- Not use. 1- Use.					
Pn161	Disturbance observer cutoff frequency	1~1000	150.0	Hz	0x0161	Immediately
	Set the disturbance compensation gain. Increasing it can improve the effect of suppressing the disturbance, but excessive noise will occur.					
Pn163	Disturbance compensation coefficient	0~100	0	%	0x0163	Immediately
	Set the disturbance compensation coefficient, that is, the received position command or speed command plus the disturbance compensation value of torque command.					
Pn165	Disturbance observer inertia correction coefficient	1~1000	100	%	0x0165	Immediately
	The disturbance observer inertia is set by this parameter to adjust the identification error caused by inaccurate inertia setting. Note: When the inertia ratio is set correctly, the value is set to 100.					
Pn166	Speed observer switch	0~1	0		0x0166	After restart
	Set speed observation function switch: 0- Invalid. 1- Valid.					
Pn167	Speed observer cutoff frequency	1~500	80	Hz	0x0167	Immediately
	This parameter sets the speed observer bandwidth. Increasing the set value will increase the response speed of the speed feedback value to track the real speed. If the speed is too large, vibration and noise may occur.					
Pn170	Friction torque compensation cutoff speed	0~1000	20	rpm	0x0170	Immediately
	Friction compensation function is a function that compensates for viscous friction and fixed load changes. It is adjusted according to the friction compensation coefficient. Generally, please set the friction compensation coefficient to 95% or less. If the effect is not obvious enough, please increase the					

	friction compensation cut-off speed at a rate of 10% each within the range that does not generate vibration.					
Pn171	Friction torque positive compensation coefficient	0~100	0	%/100rpm	0x0171	Immediately
	The setting value is higher, the effect is better. However, if the setting value is too high, the response is more likely to vibrate. Usually we set the value below 95%.					
Pn172	Friction torque reverse compensation coefficient	0~100	0	%/100rpm	0x0172	Immediately
	The setting value is higher, the effect is better. However, if the setting value is too high, the response is more likely to vibrate. Usually we set the value below 95%.					
Pn175	Robust control selection	0x00~0x01	1	—	0x0175	After restart
	Robust control function means that the function of stable response can be obtained through automatic adjustment within a certain range, regardless of mechanical type, load fluctuation, or inertia change. 0-Invalid. 1-Valid.					
Pn177	Robust control tuning value	10~80	40.0	Hz	0x0177	Immediately
	Set the gain-tuning value of the robust control. The setting value is larger, system responds is faster, but system overshoot and excessive noise may occur.					
Pn178	Minimum load value of robust control	0~500	0	%	0x0178	Immediately
	Set the robust control load factor. The larger the value is set, the faster the system responds, but it will be noisier. When the inertia is large, increasing the value properly could reduce overshoot.					
Pn185	Vibration detection selection	0x00~0x02	0	—	0x0185	Immediately
	This function refers to the function of automatically selecting alarm or warning after detecting the machine vibration under normal operation. Set the expression after vibration detection: 0 - No vibration detected. 1 - Warning after vibration detected. 2 - Alarm after vibration detected.					
Pn186	Vibration detection sensitivity	50~500	100	%	0x0186	Immediately
	Set the sensitivity of the detected vibration. The setting value is smaller, the sensitive is more. If the setting is too small, the vibration may be detected by mistake during normal operation. Note: The detection sensitivity of the vibration warning and vibration alarm may differ depending on the state of the machine being used.					
Pn187	Vibration detection value	0~5000	50	rpm	0x0187	Immediately
	Set the threshold for vibration detection. The setting value is smaller, the vibration detected is easier. If the setting is too small, the vibration may be detected by mistake during normal operation. Note: The vibration detection values of vibration warning and vibration alarm may differ according to the condition of the used machine.					

	$\frac{\text{Electronic Gear Ratio numerator}}{\text{Electronic Gear Ratio denominator}} = \frac{\text{Encoder Resolution}}{\text{Pulse Number of Upper System 1r}} \times \text{Reduction Ratio} \frac{N1}{N2}$					
	<p>When the full closed loop is valid: The electronic gear ratio is the ratio of the workpiece movement of 1 pulse unit input command by the host device to the movement of 1 pulse output by the grating ruler. If the screw is driven, the screw pitch is 10mm and the resolution of the grating ruler is 0.5um. The number of pulses required by the host system for the motor to rotate 1r is 20000, that is, the pulse equivalent is 0.5um/pulse, and the movement of the grating ruler is 0.5um, corresponding to outputting one pulse, then:</p> $\frac{\text{Electronic Gear Ratio numerator}}{\text{Electronic Gear Ratio denominator}} = \frac{\text{Input command 1 pulse corresponding movement}}{\text{Grating ruler output 1 pulse corresponding movement}} = \frac{0.5}{0.5} = \frac{1}{1}$					
Pn208	Internal position command	0~4	0	—	0x0208	After restart
	0-Position command select external pulse input. 1-Position command select internal position command. 2-Chasing and shearing electronic cam . 3-Reserved. 4-CANopen mode. When using CANopen mode, Pn208 must be set to 4 (CANopen mode).					
Pn211	Position command low-pass filter time constant	0~655	0	ms	0x0211	Cease to take effect
	This parameter is used to set the time constant of the first-order low-pass filter corresponding to the position command and it can reduce the mechanical shock in the case of abrupt changes in the input pulse command frequency by setting this parameter.					
Pn212	Average filter time in position instruction rolling	0~1000	0	ms	0x0212	Cease to take effect
	This parameter is used to set the time constant of the moving average filter of the corresponding position instruction. It can reduce the mechanical shock in the case of abrupt changes in the input pulse command frequency by setting this parameter.					
Pn230	Low-frequency vibration suppression selection	0x00~0x02	0	—	0x0230	Immediately
	This parameter is used with Pn231 as the automatic adjustment mode setting. 0- No vibration suppression. 1- Additional vibration suppression function for specific frequency. 2- Additional vibration suppression to 2 different frequencies.					
Pn231	Automatic adjustment selection in low-frequency vibration suppression	0x00~0x01	1	—	0x0231	Immediately

	This parameter is set to choose if the low-frequency vibration suppression is automatically set in the intelligent settings, bandwidth settings and other auxiliary functions: 0 - Vibration suppression function won't be automatically adjusted via auxiliary functions. 1 - Vibration suppression function will be automatically adjusted via auxiliary functions.					
Pn232	Low-frequency vibration detection sensitivity	0.1~300	40.0	%	0x0232	Immediately
	This parameter is used to set the sensitivity of low-frequency vibration detection when the positioning is completed. The smaller the sensitivity is set, the easier it is to automatically detect the low frequency vibration frequency point.					
Pn235	Low-frequency vibration suppression 1 frequency	1~200	200.0	Hz	0x0235	Immediately
	This parameter is used to set the frequency of low frequency vibration suppression 1.					
Pn236	Low Frequency Vibration suppression 1 correction	10~1000	100	%	0x0236	Immediately
	This parameter is used to set the correction coefficient of low-frequency vibration suppression 1. The larger the value is set, the more obvious the suppression effect of low-frequency is, and setting it too small may cause long positioning time.					
Pn237	Low-frequency vibration suppression 2 frequency	1~200	200.0	Hz	0x0237	Immediately
	This parameter is used to set the frequency of low-frequency vibration suppression 2.					
Pn238	Low-frequency Vibration Suppression 2 Correction	10~1000	100	%	0x0238	Immediately
	This parameter is used to set the correction coefficient of low-frequency vibration suppression 2. The larger the value is set, the more obvious the suppression effect of low-frequency is, and setting it too small may cause long positioning time.					
Pn240	Model tracking control selection	0x00~0x01	0	—	0x0240	Immediately
	0- Not use model tracking control. 1- Use model tracking control.					
Pn241	Model tracking control gain	1~2000	50.0	1/s	0x0241	Immediately
	The size of the model tracking control gain determines the response speed of the servo system. If the model tracking control gain is increased, the responsiveness becomes faster and the positioning time becomes shorter. When the model tracking control is effective, the position response and deviation of the servo system are determined by this parameter, rather than position gain.					
Pn242	Model tracking control attenuation coefficient	50~200	100.0	%	0x0242	Immediately
	The tracking attenuation coefficient of the model decreases, and the position tuning section is easy to cause excessive overshoot. If the setting is too small, the position oscillates easily. When the setting increases, the position overshoot decreases, but when the position is too large, the position easily rebounds, causing the positioning time to change long. It is recommended to keep this value, 100%, unchanged during normal use.					

Pn243	Model tracking control speed feedforward gain	0~1000	100.0	%	0x0243	Immediately
	The feed forward gain of the model tracking speed is reduced, and the responsiveness is slower, but position overshoot doesn't easily occur. If the feedforward gain is too small, the position deviation will end in a long time.					
Pn244	Model tracking control forward torque feedforward gain	0~1000	100.0	%	0x0244	Immediately
	It's a forward position command and could be used when adjusting the forward response separately. When it is increased, the torque feed forward rises faster and the positioning time can be shortened appropriately.					
Pn245	Model tracking control reverse torque feedforward gain	0~1000	100.0	%	0x0245	Immediately
	It's a reverse position command and could be used when adjusting the forward response separately. When it is increased, the torque feed forward rises faster and the positioning time can be shortened appropriately.					
Pn246	Second model tracking control attenuation coefficient	1~2000	50.0	1/s	0x0246	Immediately
	Use 2 nd gain when model tracking is valid.					
Pn247	Second model tracking control attenuation coefficient	50~200	100.0	%	0x0247	Immediately
	Use 2 nd gain when model tracking is valid.					
Pn249	Speed feedforward/torque feedforward selection	0x00~0x01	0	—	0x0249	Immediately
	0-Do not use model tracking control, external speed and torque feed forward at the same time. 1-Use model tracking control, external speed and torque feed forward at the same time. When using the model tracking control, the optimal feedforward will be set and it is not recommended to use the "speed feed forward (V-REF) input" and "torque feed forward (T-REF) input" from the upper unit at the same time. However, it can be used at the same time as needed. In this case, if the input feed forward is incorrect, it may cause overshoot and system instability.					
Pn250	Application method of external encoder in full closed loop control	0~3	0	—	0x0250	After restart
	0 - Full closed loop function is not used . 1 - Use in standard direction . 2 - Use in reverse direction . When setting the forward rotation of the motor, if the moving direction of the grating ruler is set incorrectly, it may cause an alarm of speeding or excessive deviation between the motor and load. Before operation, manually move the load and change this parameter to make the change direction of the monitoring parameter Un007 (feedback pulse counter) and Un012 (feedback pulse counter of external encoder) consistent before operation.					

Pn252	Deviation coefficient between motor loads of fully closed-loop rotating for 1 turn	0~100	20	%	0x0252	Immediately
	If this parameter is set to 0%, the deviation will be 1000 after one cycle of operation, and the deviation will be accumulated on the basis of 1000 at the beginning of the second cycle of operation. If it is set to 20%, the deviation will be accumulated on the basis of 200(1000×20% = 200) at the beginning of the second cycle of operation. If the value is set too large, Er.d10 may not be detected normally. It needs to be set according to the load and the allowable installation error between motors.					
Pn253	Resolution of external grating ruler	4~1048576	32768	Pulse /r	0x0253 0x0254	After restart
	Set the resolution of the external grating ruler after the motor runs for 1 turn (after 4 times the frequency).					
Pn257	Setting of excessive deviation between motor and load	0~1073741824	1000	Command unit	0x0257 0x0258	Immediately
	Set the alarm threshold value of excessive deviation between motor and load, which is too small, which may lead to false detection of Er.d10.					
Pn260	Position proximity signal width	1~1073741824	1073741824	Command unit	0x0260 0x0261	Immediately
	In the position control, the host device can receive the positioning proximity signal before confirming the positioning completion signal, so as to prepare for the sequence of actions after the positioning is completed and shorten the time required for the positioning to complete the operation. The signal will be output when the difference between the command pulse number of the host device and the servo motor movement (position deviation) is lower than the set value.					
Pn262	Positioning completion range	0~1073741824	7	Command unit	0x0262 0x0263	Immediately
	In the position control, the servo motor positioning completion signal will be output when the difference between the command pulse number from the host device and the servo motor movement amount (position deviation) is lower than the set value that means the host device confirming positioning has been completed.					
Pn264	Maximum position deviation threshold	1~1073741823	5242880	Command unit	0x0264 0x0265	Immediately
	When the motor operation does not match the instruction, by setting the appropriate Pn264 (maximum position deviation threshold), an abnormal condition can be detected and the motor can be stopped.					
Pn266	Excessive position deviation warning setting	10~100	100	%	0x0266	Immediately
	This parameter is used to set the position deviation excessive warning threshold. When the position deviation is greater than the product of the Pn264 (maximum position deviation threshold) and this parameter, an excessive position deviation warning will be generated.					
Pn267	Position deviation alarm threshold when the servo is ON	1~1073741823	5242880	Command unit	0x0267 0x0268	Immediately
	This parameter is used to set the threshold for excessive position deviation alarm at the moment of servo ON. When the servo is ON, if the position deviation value exceeds this setting value, an excessive servo deviation alarm will be generated when the servo is ON.					

Pn269	Position deviation warning threshold when the Servo is ON	10~100	100	%	0x0269	Immediately
	This parameter is used to set the warning threshold for excessive position deviation at the servo ON moment. When the servo is turned ON and the position deviation is greater than the product of "Excessive position deviation warning threshold at servo ON" and the parameter, the warning will be generated when the servo is ON.					
Pn270	Speed limit value when the Servo is ON	0~10000	10000	rpm	0x0270	Immediately
	If the servo is turned ON with the position deviation accumulated, the speed limit is executed by this parameter. If the servo is turned ON with the position deviation accumulated, the speed limit is executed by this parameter. When the command pulse is input in this state, the alarm Er.D02 (Excessive position deviation alarm caused by speed limit during servo ON) is displayed when the set value of Pn264 (maximum position deviation threshold) is exceeded.					
Pn272	Position deviation clear mode	0x00~0x03	0	—	0x0272	After restart
	Set the clear mode of the switch position deviation clear signal (/CLR): 0- Clear when level is ON. 1- Clear when the rising edge OFF->ON. 2- Clear when level is OFF. 3- Clear when the falling edge ON->OFF. 4- Position deviation removal . 5- Clear in case of servo off, alarm and limit .					
Pn273	Selection of position deviation clearing method	0x00~0x02	0	—	0x0273	After restart
	Set the deviation clearing method: 0- Clear when servo OFF or alarm. 1- Clear when there is /CLR signal. 2- Clear when there is alarm. 3- Do not clear. 4- Clear when servo OFF, alarm, position limit. Note: 1. For details on the pulse amplitude of the clear signal, refer to the description of "Deviation clearance". 2. In the position control, the position deviation remains unchanged when the servo motor stops due to the travel limit.					
Pn274	Positioning completion signal output time	0x00~0x02	0	—	0x0274	After restart
	Set the output timing of positioning completion signal /COIN: 0- Output when the absolute value of position deviation is less than the positioning completion range (Pn262). 1- Output when the absolute value of position deviation is less than the positioning completion range (Pn262) and the filtered position command is 0. 2- Output when the absolute value of position deviation is less than the positioning completion range (Pn262) and the position command input is 0.					

10.4 Pn3 Group Speed Related Parameters

Function code	Parameter	Range	Default	Unit	Communication address	When enabled
Pn300	Analog speed command gain	150~3000	600	0.01V/ rated speed	0x0300	Immediately
	Use this parameter to set the analog voltage value of (V-REF) when the speed of servo motor is rated speed. Note: do not apply a voltage above - 10 ~ 10V. Exceeding this range may cause damage to the drive.					
Pn301	Reversed analog speed command	0~1	0	-	0x0301	Immediately
	Set the voltage polarity of the analog speed command: 0- Positive polarity: positive voltage corresponds to positive speed command. 1- Negative polarity: positive voltage corresponds to negative speed command.					
Pn302	Analog speed instruction filter time	0~655.35	0.40	ms	0x0302	Immediately
	The function could be set to smooth the speed command when one delay filter is applied to the analog speed command (V-REF) input and it does not usually need to be changed. If the set value is too large, the responsiveness may decrease. Please set this parameter while confirming the response.					
Pn303	Analog speed command dead zone range	0~3	0	V	0x0303	Immediately
	In the analog speed control, even if the input command is 0V, the servo motor may rotate at a slight speed. This is because there is a slight deviation in the commands inside the servo unit. This error can be eliminated by setting an appropriate analog speed command deadband range.					
Pn304 Pn305 Pn306	Internal speed 1	0~10000	100	rpm	0x0304	Immediately
	Internal speed 2	0~10000	200	rpm	0x0305	Immediately
	Internal speed 3	0~10000	300	rpm	0x0306	Immediately
	When operating in the internal speed mode, the servo unit provides three internal speed commands and through Switch Internal Speed Command Selection A and B we could select as follow: /SPD-A /SPD-B Speed Command OFF OFF Zero Speed OFF ON Internal speed 1 ON ON Internal speed 2 ON OFF Internal speed 3					
Pn310	Speed command trapezoidal acceleration time	0~30000	0	ms	0x0310	Immediately
	Acceleration of the set speed from 0r/min to the rated speed (corresponding to the motor model). When the given speed is greater or less than the rated speed, the actual acceleration time is calculated in proportion.					
Pn311	Speed command trapezoidal deceleration time	0~30000	0	ms	0x0311	Immediately
	Acceleration time of the set speed from to the rated speed (corresponding to the motor model) to 0r/min. When the given speed is greater or less than the rated speed, the actual acceleration time is calculated in proportion.					

Pn312	Zero speed clamp mode	0~3	3	-	0x0312	Immediately
	Speed mode, setting the switching speed zero clamp signal (/ZCLAMP) working mode: 0-Invalid. 1-Speed command is set to 0, not clamped after shutdown. 2-Speed command is set to 0, clamped after shutdown. 3-Speed command is lower than "zero speed clamp speed threshold"(Pn313), the first speed command is set to 0, clamped after shutdown.					
Pn313	Zero speed clamp speed threshold	0~10000	10	rpm	0x0313	Immediately
	Set the zero control switching threshold when "zero speed clamp mode"(Pn312) is set to 3.					
Pn317	Rotation determination threshold	1~10000	20	rpm	0x0317	Immediately
	When the motor speed is higher than the set value, the switch rotation detection signal (/TGON) is output.					
Pn320	Speed consistent range	0~100	10	rpm	0x0320	Immediately
	When the difference between the motor speed and the command speed is lower than the set value, the switch-speed match signal (/V-CMP) would be output.					

10.5 Pn4 Group Torque Related Parameters

Function code	Parameter	Range	Default	Unit	Communication address	When enabled
Pn400	Torque command selection	0~1	1	-	0x0400	Immediately
	Select the torque control command source: 0- Internal setting. 1- Analog input.					
Pn401	Torque command second-order low-pass filter cut-off frequency	100~5000	5000	Hz	0x0401	Immediately
	This parameter is used to set the cut-off frequency of the second-order torque filter. When this parameter is set to 5000, the filter function is invalid.					
Pn402	Torque command second-order low-pass filter Q	0.5~1	0.50	1	0x0402	Immediately
	This parameter is used to set the Q value of the second-order torque filter. Increasing the Q value can improve the system response, but noise will be generated when the setting is too large.					
Pn403	Torque command direction setting	0~1	0	-	0x0403	Immediately
	Set the switching torque command direction selection (/T-SIGN) signal to activate the switch: 0 - Torque command direction selection (/T-SIGN) signal is invalid. 1 - Torque command direction selection (/T-SIGN) signal is valid. Note: Torque command reversion is invalid when /T-SIGN is valid. Torque command is positive when /T-SIGN signal is ON, and torque command is negative when /T-SIGN signal is OFF.					
Pn404	Analog torque command filter time	0~655.35	0.00	ms	0x0404	Immediately

	The parameter is used to smooth the torque command when we apply 1 delay filter to the analog torque command (T-REF) input, usually it does not need to be changed. If the set value is too large, the responsiveness may decrease. So please set it up as we check the response.					
Pn405	Analog torque command gain	10~100	30	0.1V/ Rated torque	0x0405	Immediately
	This parameter is used to set the analog (T-REF) voltage value which corresponds the rated torque of the servo motor. Caution: Do not apply more than -10V~10V, exceeding this range may cause damage to the driver.					
Pn406	Reversed analog torque command	0~1	0	-	0x0406	Immediately
	The analog voltage corresponds to the polarity setting of the torque command: 0-Positive polarity: Positive voltage corresponds to positive torque command. 1-Negative polarity: Positive voltage corresponds to negative torque command.					
Pn407	Analog torque command dead zone range	0~3	0	V	0x0407	Immediately
	In analog torque control, even if the input command is 0V, the servo motor may rotate at a slight speed. This is because a slight deviation occurs in the command inside the servo unit. This error can be eliminated by setting an appropriate analog torque command deadband range.					
Pn410	Internal torque command in torque control	-500~500	0	%	0x0410	Immediately
	Select the torque command setting when the command source of torque control is internal setting.					
Pn411	Speed limit mode setting during torque control	0~1	1	-	0x0411	After restart
	0-The smaller value between the speed corresponding to the analog voltage (V-ref) and the speed set by Pn413. 1-The speed set by Pn413.					
Pn412	Speed limit selection	0x00~0x01	0	—	0x0412	After restart
	0- Motor maximum speed (determined by internal part of the motor model) + torque mode speed limit (Pn411). 1- Overspeed detection alarm speed (determined by internal part of the motor model) + torque mode speed limit (Pn411).					
Pn413	Speed limit in torque control	0~10000	1000	rpm	0x0413	Immediately
	This parameter is used to set speed limit in torque control with Pn411.					
Pn415	Internal torque control command smooth acceleration time	0~30000	100	ms	0x0415	Immediately
	Set the internal torque control command smooth acceleration time.					
Pn416	Internal torque control command smooth deceleration time	0~30000	100	ms	0x0416	Immediately
	Set the internal torque control command smooth deceleration time.					
Pn420	Target torque reaching value setting	0.0~500.0	100	-	0x0420	Immediately

	Set the target torque reaching value.					
Pn421	Target torque reaching time window	0~1000	5	ms	0x0422	Immediately
	Set target torque reaching time window.					

10.6 Pn5 JOG Related Parameters

Function code	Parameter	Range	Default	Unit	Communication address	When enabled
Pn500	JOG speed	0~1000	500	rpm	0x0500	Immediately
Pn502	Program JOG operation mode	0x00~0x05	0	—	0x0502	Immediately
		0-(waiting time->forward running)*number of cycles. 1-(waiting time->backward running)*number of cycles. 2-(waiting time->forward running)*number of cycles->(waiting time->backward running)*number of cycles. 3-(waiting time->backward running)*number of cycles->(waiting time->forward running)*number of cycles. 4-(waiting time->forward running->waiting time->backward running)*number of cycles. 5-(waiting time->backward running->waiting time->forward running)*number of cycles.				
Pn503	Program JOG running distance	1~1073741824	32768	command unit	0x0503	Immediately
		Set the JOG movement distance of the running program as the command unit.				
Pn505	Program JOG acceleration/ deceleration time	2~10000	100	ms	0x0505	Immediately
		Set the time of accelerating from 0r/min to the rated speed (corresponding to the motor model). When the set speed is greater or less than the rated speed, calculate the actual acceleration/deceleration time according to the ratio.				
Pn506	Program JOG waiting time	0~10000	100	ms	0x0506	Immediately
		Set the waiting time between JOG sections of the running program in conjunction with the program JOG operation mode (Pn502).				
Pn507	Program JOG movement times	0~1000	1	circle	0x0507	Immediately
		Set the movement times of the running program in conjunction with JOG operation mode (Pn502) Note: it is infinite when set to 0.				
Pn508	Program JOG movement speed	1~10000	500	rpm	0x0508	Immediately

10.7 Pn6 Group Switch Configuration Related Parameters

Function code	Parameter	Range	Default	Unit	Communication address	When enabled
Pn600	Switching value input signal distribution mode	0~1	1	-	0x0600	After restart

	Set switching value input signal distribution mode: 0-Internal fixed: used by pins and functions are fixed inside by servo unit. See "CN1 terminal" for details. 1-Parameter configuration: It is used according to the function configured on each pin and is configured and used by function code Pn601~Pn609.					
	CN1-40 input configuration	0~0x114	0x01	-	0x0601	After restart
	CN1-42 input configuration	0~0x114	0x02	-	0x0602	After restart
	CN1-43 input configuration	0~0x114	0x03	-	0x0603	After restart
	CN1-41 input configuration	0~0x114	0x05	-	0x0604	After restart
	CN1-44 input configuration	0~0x114	0x04	-	0x0605	After restart
	CN1-45 input configuration	0~0x114	0x06	-	0x0606	After restart
	CN1-46 input configuration	0~0x114	0x07	-	0x0607	After restart
	CN1-39 input configuration	0~0x114	0x00	-	0x0608	After restart
	CN1-38 input configuration	0~0x114	0x00	-	0x0609	After restart
Pn601 Pn602 Pn603 Pn604 Pn605 Pn606 Pn607 Pn608 Pn609	0x00: Invalid					
	0x01: Servo enable		0x101: Servo enable negation			
	0x02: Run in positive direction		0x102: Positive direction is prohibited			
	0x03: Run in negative direction		0x103: Negative direction is prohibited			
	0x04: Alarm clear		0x104: Alarm clear negation			
	0x05: Manual P-PI control		0x105: Manual P-PI control negation			
	0x06: Torque limit switch		0x106: Torque limit switch negation			
	0x07: Reserved		0x107: Reserved			
	0x08: Internal speed command direction selection		0x108: Internal speed command direction selection negation			
	0x09: Internal speed command selection A		0x109: Internal speed command selection A negation			
	0x0A: Internal speed command selection B		0x10A: Internal speed command selection B negation			
	0x0B: Control mode switch		0x10B: Control mode switch negation			
	0x0C: Zero speed clamp		0x10C: Zero speed clamp negation			
	0x0D: Command pulse inhibit		0x10D: Command pulse inhibit negation			
	0x0E: Gain switching		0x10E: Gain switching negation			
	0x0F: Direction selection of torque command		0x10F: Direction selection of torque command negation			
	0x10: Command pulse rate switching		0x110: Command pulse rate switch negation			
	0x12: Motor over temperature input		0x112: Motor over temperature input negation			
	0x16: Internal position command trigger		0x116: Internal position command triggers negation			
	0x17: Internal position instruction selection bit0		0x117: Internal position instruction selection bit0 negation			
0x18: Internal position instruction selection bit1		0x118: Internal position instruction selection bit1 negation				
0x19: Internal position instruction selection bit2		0x119: Internal position instruction selection bit2 negation				

	0x1A: Internal position instruction selection bit3			0x11A: Internal position instruction selection bit3 negation	
	0x1B: Internal position instruction selection bit3			0x11B: Internal position instruction selection bit3 negation	
	0x1C: Home position return enable			0x11C: Home position return enable negation	
	0x1D: Origin signal			0x11D: Origin signal negation	
	0x1E: Forward JOG			0x11E: Forward JOG negation	
	0x1F: Reverse JOG			0x11F: Reverse JOG negation	
	0x20: Internal position stop bit			0x120: Internal position stop bit negation	
	0x21: Capture function on			0x121: Capture function on negation	
Pn610 Pn611 Pn612	Switch input internal configuration 1	0~0x14	0x00	-	0x0610 After restart
	Switch input internal configuration 2	0~0x14	0x00	-	0x0611 After restart
	Switch input internal configuration 3	0~0x14	0x00	-	0x0612 After restart
	0x00: Invalid				
	0x01: Servo enable			0x101: Servo enable negation	
	0x02: Run in positive direction			0x102: Positive direction is prohibited	
	0x03: Run in negative direction			0x103: Negative direction is prohibited	
	0x04: Alarm clear			0x104: Alarm clear negation	
	0x05: Manual P-PI control			0x105: Manual P-PI control negation	
	0x06: Torque limit switch			0x106: Torque limit switch negation	
	0x07: Reserved			0x107: Reserved	
	0x08: Internal speed command direction selection			0x108: Internal speed command direction selection negation	
	0x09: Internal speed command selection A			0x109: Internal speed command selection A negation	
	0x0A: Internal speed command selection B			0x10A: Internal speed command selection B negation	
	0x0B: Control mode switch			0x10B: Control mode switch negation	
	0x0C: Zero speed clamp			0x10C: Zero speed clamp negation	
	0x0D: Command pulse inhibit			0x10D: Command pulse inhibit negation	
	0x0E: Gain switching			0x10E: Gain switching negation	
	0x0F: Direction selection of torque command			0x10F: Direction selection of torque command negation	
	0x10: Command pulse rate switching			0x110: Command pulse rate switch negation	
	0x12: Motor over temperature input			0x112: Motor over temperature input negation	
	0x16: Internal position command trigger			0x116: Internal position command triggers negation	
	0x17: Internal position instruction selection bit0			0x117: Internal position instruction selection bit0 negation	
	0x18: Internal position instruction selection bit1			0x118: Internal position instruction selection bit1 negation	
	0x19: Internal position instruction selection bit2			0x119: Internal position instruction selection bit2 negation	
	0x1A: Internal position instruction selection bit3			0x11A: Internal position instruction selection bit3 negation	
	0x1B: Internal position instruction selection bit3			0x11B: Internal position instruction selection bit3 negation	

	0x1C: Home position return enable		0x11C: Home position return enable negation			
	0x1D: Origin signal		0x11D: Origin signal negation			
	0x1E: Forward JOG		0x11E: Forward JOG negation			
	0x1F: Reverse JOG		0x11F: Reverse JOG negation			
	0x20: Internal position stop bit		0x120: Internal position stop bit negation			
	0x21: Capture function on		0x121: Capture function on negation			
	Pn613 Pn614 Pn615	CN1-25, 26 output configuration	0~0x109	0x000	-	0x0613
CN1-27, 28 output configuration		0~0x109	0x001	-	0x0614	After restart
CN1-29, 30 output configuration		0~0x109	0x002	-	0x0615	After restart
0x00: Servo ready (S-RDY)		0x100: Servo ready signal negation				
0x01: Positioning completed (COIN)		0x101: Positioning completion signal negation				
0x02: Speed is consistent (V-CMP)		0x102: Speed match signal negation				
0x03: Rotation detection signal		0x103: Rotation detection signal negation				
0x04: In the torque limit		0x104: The signal in the torque limit negation				
0x05: In speed limit		0x105: The signal in speed limit negation				
0x06: Brake chain		0x106: Brake chain signal negation				
0x07: Warning		0x107: Warning signal negation				
0x08: Positioning proximity signal		0x108: Positioning proximity signal negation				
0x09: Command pulse input magnification switching signal		0x109: Command pulse input magnification switching signal negation				
0x0A: Torque reaching signal output		0x10A: Torque reaching signal output negation				
0x11: Home position return completion signal		0x111: Home position return completion signal negation				
Pn622	Function selector switch	0x00~0x11	0	—	0x0622	After restart
	Function selector switch: 0x1#: Output (ALM) signal high effective. 0x0#: Output (ALM) signal low effective. 0x#1: No warning detected. 0x#0: Warning detected.					
Pn623	Si terminal input filtering time	0~32767	0	ms	0x0623	

10.8 Pn7 Group Expansion Related Parameters

Function code	Parameter	Range	Default	Unit	Communication address	When enabled
Pn702	Inertia identification movable range	0.2~20.0	2	r	0x0702	Immediately
	Number of rotations of motor in inertia identification.					
Pn705	Initial value of inertia identification	0~20000	0	%	0x0705	Immediately
	Initial value setting of inertia identification.					

Pn706	Vibration detection level (rotation) in inertia identification	0~5000	0	r/min	0x0705	Immediately
	Vibration detection level (rotation) setting in inertia identification.					
Pn730	Function test selection without motor	0x00~0x01	0	—	0x0730	After restart
	The function test without motor is not to start the real motor, simulate the action of the motor in the servo unit, and confirm the action of the host device and peripheral equipment. Through this function, wiring confirmation, parameter value verification and verification in case of system commissioning failure can be carried out, so as to shorten the set operation time and avoid mechanical damage caused by wrong action. When no motor test function is running, the motor action can be confirmed whether the motor is connected or not. 0-Invalid. 1-Valid.					
Pn731	Encoder resolution selection when no-motor test function	0~3	1	—	0x0731	After restart
	When no-motor test mode is selected, the motor encoder resolution is set: 0-13 bits 1-17 bits 2-20 bits 3-23 bits Note: when the encoder is actually connected, the resolution of the actual encoder is used.					
Pn732	No-Motor test function encoder type selection	0x00~0x01	0	—	0x0732	After restart
	Set no-motor test function encoder type: 0-Incremental encoder. 1-Absolute encoder.					
Pn792	Absolute encoder operation	0~2	0	—	0x0792	After restart
	0 - No action. 1 - Write motor parameters to encoder EEPROM. 2 - Clear multi-turn encoder circles: if you use it initially or replace or insert/remove the battery during power-down of the drive. After power on, an encoder backup alarm (Er. 810) will be reported. This parameter is set to 2 and it can only be cleared after re-powered. 3 - Only clear encoder alarm: when the encoder gives an alarm (Er.810, Er.860,), set this parameter to 3 to clear the encoder alarm, but do not clear the multi turn value of the encoder, and keep the current position of the motor.					
Pn798	Zero offset of multi turn absolute encoder	0~2147483647	0	command unit	0x0792	After restart
	Set zero offset of multi turn absolute encoder.					
Pn79A	Minimum software limit absolute position (32 bits)	-2147483648 ~2147483647	-2147483648 8	command unit	0x079A	After restart
	When the absolute position of the motor (Un021) is less than this position, the servo enters the limit alarm state.					
Pn79C	Maximum software limit absolute position (32 bits)	-2147483648 ~2147483647	-2147483648 8	command unit	0x079C	After restart
	When the absolute position of the motor (Un021) is greater than this position, the servo enters the limit alarm state.					
Pn79E	Software limit absolute position switch	0~1	0	N/A	0x079E	Immediately
	0: Close 1: Open					

Pn7A0	Encoder overflow times	32768~32767	0	N/A	0x07A0	Immediately
	Record the number of times the multi turn absolute encoder overflows.					
Pn7A1	Percentage of motor locked rotor overload protection time	0~100	8	N/A	0x07A1	After restart
	This parameter sets the time percentage of motor overload after locked rotor. If the setting is too large, the driver may be damaged. In order to protect the safety of the driver, please change this value under the guidance of the manufacturer's technical support.					

10.9 Pn8 Group Internal Position/Home Position Return Parameters

Function code	Parameter	Range	Default	Unit	Communication address	When enabled
Pn800	Home position return control word	0~ 0xFFFFFFFF	0x0	-	0x0800	Immediately
	Home position return control word mode setting, see Chapter 8 for details.					
Pn802	Zero position offset value	- 2147483648 ~ 2147483647	0	command unit	0x0802	Immediately
	Set zero position offset position.					
Pn804	Pr1 control word	0~ 0x80000000	0x0	—	0x0804	Immediately
	Position setting of the first section, see Chapter 8 for details.					
Pn806	Pr1 pulse number	- 2147483648 ~ 2147483647	0	command unit	0x0806	Immediately
	Set the position of the 1 st segment.					
Pn808	Pr2 control word	0~ 0x80000000	0x0	—	0x0808	Immediately
	Same as Pn804.					
Pn80A	Pr2 pulse number	- 2147483648 ~ 2147483647	0	command unit	0x0810	After restart
	Set the position of the 2 nd segment.					
Pn80C	Pr3 control word	0~ 0x80000000	0x0	—	0x080C	After restart
	Same as Pn804.					
Pn80E	Pr3 pulse number	- 2147483648 ~ 2147483647	0	command unit	0x080E	Immediately
	Set the position of the 3 rd segment.					
Pn810	Pr4 control word	0~ 0x80000000	0x0	—	0x0810	Immediately

	Same as Pn804.					
Pn812	Pr4 pulse number	- 2147483648 ~ 2147483647	0	command unit	0x0812	Immediately
	Set the position of the 4 th segment.					
Pn814	Pr5 control word	0~ 0x80000000	0x0	—	0x0814	Immediately
	Same as Pn804.					
Pn816	Pr5 pulse number	- 2147483648 ~ 2147483647	0	command unit	0x0816	Immediately
	Set the position of the 5 th segment.					
Pn818	Pr6 control word	0~ 0x80000000	0x0	—	0x0818	Immediately
	Same as Pn804.					
Pn81A	Pr6 pulse number	- 2147483648 ~ 2147483647	0	command unit	0x081A	Immediately
	Set the position of the 6 th segment.					
Pn81C	Pr7 control word	0~ 0x80000000	0x0	—	0x081C	Immediately
	Same as Pn804.					
Pn81E	Pr7 pulse number	- 2147483648 ~ 2147483647	0	command unit	0x081E	Immediately
	Set the position of the 7 th segment.					
Pn820	Pr8 control word	0~ 0x80000000	0x0	—	0x0820	Immediately
	Same as Pn804.					
Pn822	Pr8 pulse number	- 2147483648 ~ 2147483647	0	command unit	0x0822	Immediately
	Set the position of the 8 th segment.					
Pn824	Pr9 control word	0~ 0x80000000	0x0	—	0x0824	Immediately
	Same as Pn804.					
Pn826	Pr9 pulse number	- 2147483648 ~ 2147483647	0	command unit	0x0826	Immediately
	Set the position of the 9 th segment.					
Pn828	Pr10 control word	0~ 0x80000000	0x0	—	0x0828	Immediately
	Same as Pn804.					

Pn82A	Pr10 pulse number	2147483648 ~ 2147483647	0	command unit	0x082A	Immediately
	Set the position of the 10 th segment.					
Pn82C	Pr11 control word	0~ 0x80000000	0x0	—	0x082C	Immediately
	Same as Pn804.					
Pn82E	Pr11 pulse number	2147483648 ~ 2147483647	0	command unit	0x082E	Immediately
	Set the position of the 11 th segment.					
Pn830	Pr12 control word	0~ 0x80000000	0x0	—	0x0830	Immediately
	Same as Pn804.					
Pn832	Pr12 pulse number	2147483648 ~ 2147483647	0	command unit	0x0832	Immediately
	Set the position of the 12 th segment.					
Pn834	Pr13 control word	0~ 0x80000000	0x0	—	0x0834	Immediately
	Same as Pn804.					
Pn836	Pr13 pulse number	2147483648 ~ 2147483647	0	command unit	0x0836	Immediately
	Set the position of the 13 th segment.					
Pn838	Pr14 control word	0~ 0x80000000	0x0	—	0x0838	Immediately
	Same as Pn804.					
Pn83A	Pr14 pulse number	2147483648 ~ 2147483647	0	command unit	0x083A	Immediately
	Set the position of the 14 th segment.					
Pn83C	Pr15 control word	0~ 0x80000000	0x0	—	0x083C	Immediately
	Same as Pn804.					
Pn83E	Pr15 pulse number	2147483648 ~ 2147483647	0	command unit	0x083E	Immediately
	Set the position of the 15 th segment.					
Pn840	Pr16 control word	0~ 0x80000000	0x0	—	0x0840	Immediately

	Same as Pn804.					
Pn842	Pr16 pulse number	2147483648 ~ 2147483647	0	command unit	0x0840	Immediately
	Set the position of the 16 th segment.					
Pn844	Pr17 control word	0~ 0x80000000	0x0	—	0x0844	Immediately
	Same as Pn804.					
Pn846	Pr17 pulse number	2147483648 ~ 2147483647	0	command unit	0x0846	Immediately
	Set the position of the 17 th segment.					
Pn848	Pr18 control word	0~ 0x80000000	0x0	—	0x0848	Immediately
	Same as Pn804.					
Pn84A	Pr18 pulse number	2147483648 ~ 2147483647	0	command unit	0x084A	Immediately
	Set the position of the 18 th segment.					
Pn84C	Pr19 control word	0~ 0x80000000	0x0	—	0x084C	Immediately
	Same as Pn804.					
Pn84E	Pr19 pulse number	2147483648 ~ 2147483647	0	command unit	0x084E	Immediately
	Set the position of the 19 th segment.					
Pn850	Pr20 control word	0~ 0x80000000	0x0	—	0x0850	Immediately
	Same as Pn804.					
Pn852	Pr20 pulse number	-2147483648~ 2147483647	0	Unit	0x0852	Immediately
	20th position setting.					
Pn854	Pr21 control word	0~ 0x80000000	0x0	—	0x0854	Immediately
	Like Pn804.					
Pn856	Pr21 pulse number	-2147483648~ 2147483647	0	Unit	0x0856	Immediately
	21th position setting.					
Pn858	Pr22 control word	0~ 0x80000000	0x0	—	0x0856	Immediately
	Like Pn804.					
Pn85A	Pr22 pulse number	-2147483648~ 2147483647	0	Unit	0x085A	Immediately

	22th position setting.					
Pn85C	Pr23 control word	0~ 0x80000000	0x0	—	0x085C	Immediately
	Like Pn804.					
Pn85E	Pr23 pulse number	-2147483648~ 2147483647	0	Unit	0x085E	Immediately
	23th position setting.					
Pn860	Pr24 control word	0~ 0x80000000	0x0	—	0x0860	Immediately
	Like Pn804.					
Pn862	Pr24 pulse number	-2147483648~ 2147483647	0	Unit	0x0862	Immediately
	24th position setting.					
Pn864	Pr25 control word	0~ 0x80000000	0x0	—	0x0864	Immediately
	Like Pn804.					
Pn866	Pr25 pulse number	-2147483648~ 2147483647	0	Unit	0x0866	Immediately
	25th position setting.					
Pn868	Pr26 control word	0~0x80000000	0x0	—	0x0868	Immediately
	Like Pn804.					
Pn86A	Pr26 pulse number	-2147483648~ 2147483647	0	Unit	0x086A	Immediately
	26th position setting.					
Pn86C	Pr27 control word	0~ 0x80000000	0x0	—	0x086C	Immediately
	Like Pn804.					
Pn86E	Pr27 pulse number	-2147483648~ 2147483647	0	Unit	0x086E	Immediately
	27th position setting.					
Pn870	Pr28 control word	0~ 0x80000000	0x0	—	0x0870	Immediately
	Like Pn804.					
Pn872	Pr28 pulse number	-2147483648~ 2147483647	0	Unit	0x0872	Immediately
	28th position setting.					
Pn874	Pr29 control word	0~ 0x80000000	0x0	—	0x0874	Immediately
	Like Pn804.					
Pn876	Pr29 pulse number	-2147483648~ 2147483647	0	Unit	0x0876	Immediately
	29th position setting.					
Pn878	Pr30 control word	0~ 0x80000000	0x0	—	0x0878	Immediately
	Like Pn804.					

Pn87A	Pr30 pulse number	-2147483648 ~ 2147483647	0	Unit	0x087A	Immediately
	30th position setting.					
Pn87C	Pr31 control word	0 ~ 0x80000000	0x0	—	0x087C	Immediately
	Like Pn804.					
Pn87E	Pr31 pulse number	-2147483648 ~ 2147483647	0	Unit	0x087E	Immediately
	31th position setting.					
Pn880	Pr Acc and dec time 0	0 ~ 60000	50	ms	0x0880	Immediately
	Acc and dec time setting 0.					
Pn881	Pr Acc and dec time 1	0 ~ 60000	200	ms	0x0881	Immediately
	Acc and dec time setting 1.					
Pn882	Pr Acc and dec time 2	0 ~ 60000	300	ms	0x0882	Immediately
	Acc and dec time setting 2.					
Pn883	Pr Acc and dec time 3	0 ~ 60000	400	ms	0x0883	Immediately
	Acc and dec time setting 3.					
Pn884	Pr Acc and dec time 4	0 ~ 60000	500	ms	0x0884	Immediately
	Acc and dec time setting 4.					
Pn885	Pr Acc and dec time 5	0 ~ 60000	600	ms	0x0885	Immediately
	Acc and dec time setting 5.					
Pn886	Pr Acc and dec time 6	0 ~ 60000	700	ms	0x0886	Immediately
	Acc and dec time setting 6.					
Pn887	Pr Acc and dec time 7	0 ~ 60000	800	ms	0x0887	Immediately
	Acc and dec time setting 7.					
Pn888	Pr target speed 0	0 ~ 6000	100	r/min	0x0888	Immediately
	target speed 0 setting.					
Pn889	Pr target speed 1	0 ~ 6000	200	r/min	0x0889	Immediately
	target speed 1 setting.					
Pn88A	Pr target speed 2	0 ~ 6000	500	r/min	0x088A	Immediately
	target speed 2 setting.					
Pn88B	Pr target speed 3	0 ~ 6000	1000	r/min	0x088B	Immediately
	target speed 3 setting.					
Pn88C	Pr target speed 4	0 ~ 6000	1500	r/min	0x088C	Immediately
	target speed 4 setting.					
Pn88D	Pr target speed 5	0 ~ 6000	2000	r/min	0x088D	Immediately
	target speed 5 setting.					

Pn88E	Pr target speed 6	0~6000	2500	r/min	0x088E	Immediately
	target speed 6 setting.					
Pn88F	Pr target speed 7	0~6000	3000	r/min	0x088F	Immediately
	target speed 7 setting.					
Pn890	Pr delay time0	0~6000	0	0.1s	0x0890	Immediately
	Delay time0 setting.					
Pn891	Pr delay time 1	0~6000	1	0.1s	0x0891	Immediately
	Delay time 1 setting.					
Pn892	Pr delay time 2	0~6000	5	0.1s	0x0892	Immediately
	Delay time 2 setting.					
Pn893	Pr delay time 3	0~6000	10	0.1s	0x0893	Immediately
	Delay time 3 setting.					
Pn894	Pr delay time 4	0~60000	100	0.1s	0x0894	Immediately
	Delay time4 setting.					
Pn895	Pr delay time 5	0~60000	1000	0.1s	0x0895	Immediately
	Delay time 5 setting.					

11 Monitoring Parameters

Monitoring code	Monitoring name	Range	Unit	Communication address
Un000	Motor rotation speed	0x80000000~0x7ffffff	rpm	0xE000
	Display the actual speed of the servo motor.			
Un001	Speed command	0x80000000~0x7ffffff	rpm	0xE001
	Display the current speed command of the servo motor. Note: When it is not enabled, this value shows the analog speed (corresponding to V-REF).			
Un002	Internal torque command	0x80000000~0x7ffffff	%	0xE002
	Display current actual torque command with servo motor rated torque as 100%.			
Un003	Rotor pulse position relative to the Z axis	0x80000000~0x7ffffff	pulse	0xE003
	Shows the mechanical absolute position of the motor within one revolution of the encoder.			
Un004	Electrical angle	0x80000000~0x7ffffff	°	0xE004
	Displays the electrical angle of the current position of the servo motor rotor.			
Un005	Speed of input pulse command	0x80000000~0x7ffffff	rpm	0xE005
	Display input position pulse command speed.			
Un006	Counter of input command pulse	0x80000000~0x7ffffff	Command Unit	0xE006
	Displays the number of command pulses received by the servo motor.			
Un007	Counter of feedback pulse	0x80000000~0x7ffffff	Command Unit	0xE007
	Displays cumulative pulses fed back from the servo motor encoder.			
Un008	Counter of feedback pulse 1	0x80000000~0x7ffffff	Encoder pulse unit	0xE008
	Displays cumulative pulses fed back from the servo motor encoder.			
Un009	Position deviation	0x80000000~0x7ffffff	Command Unit	0xE009
	Display the difference between the command pulse number of the upper device and the servo motor movement amount.			
Un010	Absolute encoder single-turn value	0x80000000~0x7FFFFFFF	Encoder unit	0xE010
	Display the absolute position value of one-turn of the absolute encoder.			
Un011	Absolute encoder multi-turn value	0x80000000~0x7FFFFFFF	-	0xE011
	Displays the number of multi-turn encoder turns value when the multi-turn encoder is used. After the multi-turn encoder reset operation is performed, the value is 0.			
Un012	External encoder feedback pulse counter	0x80000000~0x7FFFFFFF	External encoder unit	0xE012
	Display external encoder feedback pulse counter when external grating encoder is connected.			
Un021	Motor absolute position	0x80000000~0x7FFFFFFF	command unit	0xE021
	Display the absolute position of the motor, the unit is the command unit.			

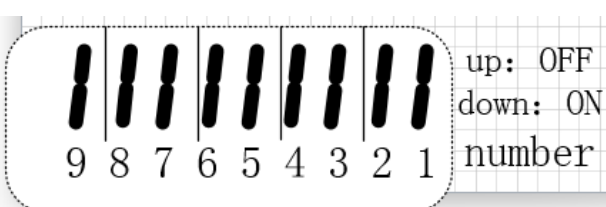
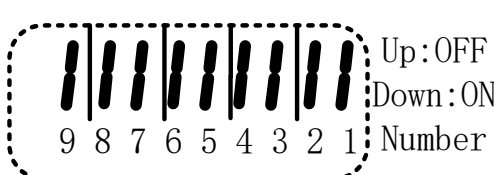
Un00A	Cumulative load rate	0x80000000~0x7fffffff	%	0xE00A																													
Un00B	Regeneration load rate	0x80000000~0x7fffffff	%	0xE00B																													
Un00C	Electricity consumption of DB resistance	0x80000000~0x7fffffff	%	0xE00C																													
Un00D	Effective gain monitoring	1~2	-	0xE00D																													
Un00E	Total running time	0~0xFFFFFFFF	100ms	0xE00E																													
Un00F	Overload rate	0~0xFFFFFFFF	%	0xE00F																													
Un035	DSP software version	0~0xFFFF	-	0xE035																													
Un036	FPGA software version	0~0xFFFF	-	0xE036																													
Un087	Encoder communication abnormal times	0~0xFFFF	-	0xE087																													
Un089	Heat sink temperature	0~0xFFFF	°C	0xE090																													
Un091	Motor temperature	0~0xFFFF	°C	0xE091																													
Un100	IO port input signal monitoring	0~0xFFFF	-	0xE100																													
	 <p>up: OFF down: ON number</p> <table border="1" data-bbox="255 831 994 1094"> <thead> <tr> <th>LED</th> <th>Input pin number</th> <th>Signal name (Factory configuration)</th> <th>LED</th> <th>Input pin number</th> </tr> </thead> <tbody> <tr> <td>1</td> <td>CN1-40</td> <td>/S-ON</td> <td>6</td> <td>CN1-45</td> </tr> <tr> <td>2</td> <td>CN1-41</td> <td>/P-CON</td> <td>7</td> <td>CN1-46</td> </tr> <tr> <td>3</td> <td>CN1-42</td> <td>P-OT</td> <td>8</td> <td>CN1-39</td> </tr> <tr> <td>4</td> <td>CN1-43</td> <td>N-OT</td> <td>9</td> <td>CN1-38</td> </tr> <tr> <td>5</td> <td>CN1-44</td> <td>/ALM-RST</td> <td></td> <td></td> </tr> </tbody> </table>				LED	Input pin number	Signal name (Factory configuration)	LED	Input pin number	1	CN1-40	/S-ON	6	CN1-45	2	CN1-41	/P-CON	7	CN1-46	3	CN1-42	P-OT	8	CN1-39	4	CN1-43	N-OT	9	CN1-38	5	CN1-44	/ALM-RST	
LED	Input pin number	Signal name (Factory configuration)	LED	Input pin number																													
1	CN1-40	/S-ON	6	CN1-45																													
2	CN1-41	/P-CON	7	CN1-46																													
3	CN1-42	P-OT	8	CN1-39																													
4	CN1-43	N-OT	9	CN1-38																													
5	CN1-44	/ALM-RST																															
Un101	IO port output signal monitoring	0~0xFFFF	-	0xE101																													
	 <p>Up: OFF Down: ON Number</p>																																

	LED		Input pin number	
	1		CN1-31/32	
	2		CN1-25/26	
	3		CN1-27/28	
	4		CN1-29/30	
Un102	T-REF monitoring	0~0xFFFF	%	0xE102
	Corresponds to the T-REF input voltage, according to the analog torque command gain.			
Un103	V-REF monitoring	0~0xFFFF	rpm	0xE103
	Corresponds to the T-REF input voltage, according to the analog torque command gain.			
Un104	Pulse command input frequency	0~0xFFFFFFFF	Hz	0xE104
Un108	External input command pulse counter	0~0xFFFFFFFF	Command Unit	0xE108
Un110	Integrated monitoring of internal signal status	0~0xFFFFFFFF	-	0xE110
Un120	Integrated monitoring of internal input signal status	0~0xFFFFFFFF	-	0xE120
Un130	Integrated monitoring of internal output signal	0~0xFFFFFFFF	-	0xE130
Un140	Main circuit bus voltage	0~0xFFFF	V	0xE140
Un141	Effective current feedback	0~0xFFFF	0.01A	0xE141
	Three-phase synthetic feedback current effective value.			
Un14B	D-axis current command monitoring	0~0xFFFF	%	0xE14B
Un220	Torque command voltage (uncorrected)	0~0xFFFF	mv	0xE220
Un221	Torque command voltage (after correction)	0~0xFFFF	mv	0xE221
Un222	Speed command voltage (uncorrected)	0~0xFFFF	mv	0xE222
Un223	Speed command voltage (after correction)	0~0xFFFF	mv	0xE223
Un300	Current alarm code	0~0xFFFF	-	0xE300
Un301	Last alarm code	0~0xFFFF	-	0xE301
Un302	Timestamp while alarm occurs	0~0xFFFFFFFF	100ms	0xE302
Un303	Motor speed while alarm occurs	0~0xFFFF	rpm	0xE303
Un304	Speed command while alarm occurs	0~0xFFFF	rpm	0xE304
Un305	Internal torque command while alarm occurs	0~0xFFFF	%	0xE305
Un306	Input command pulse speed while alarm occurs	0~0xFFFF	rpm	0xE306
Un307	Deviation counters (position deviation)while alarm occurs	0~0xFFFFFFFF	pulse	0xE307
Un308	DC bus voltage while alarm occurs	0~0xFFFF	V	0xE308

Un309	Effective current feedback while alarm occurs	0~0xFFFF	%	0xE309
Un30A	Cumulative load rate while alarm occurs	0~0xFFFF	%	0xE30A
Un30B	Regenerative load rate while alarm occurs	0~0xFFFF	%	0xE30B
Un30C	Electricity consumption of DB resistance while alarm occurs	0~0xFFFF	%	0xE30C
Un30D	Maximum cumulative load rate while alarm occurs	0~0xFFFF	%	0xE30D
Un30E	Rotation inertia ratio while alarm occurs	0~0xFFFF	%	0xE30E
Un30F	Abnormal times of serial encoder communication while alarm occurs	0~0xFFFF	-	0xE30F
Un310	Internal signal monitoring while alarm occurs	0~0xFFFFFFFF	-	0xE310
Un313	Internal input signal monitoring while alarm occurs	0~0xFFFFFFFF	-	0xE313
Un317	Internal output signal monitoring while alarm occurs	0~0xFFFFFFFF	-	0xE317
Un30F	The number of serial encoder communication abnormalities when an alarm occurs	0~0xFFFF	—	0xE30F
Un320	Fault code history 1	0~0xFFFF	-	0xE320
Un321	Fault code history 2	0~0xFFFF	-	0xE321
Un322	Fault code history 3	0~0xFFFF	-	0xE322
Un323	Fault code history 4	0~0xFFFF	-	0xE323
Un324	Fault code history 5	0~0xFFFF	-	0xE324
Un325	Fault code history 6	0~0xFFFF	-	0xE325

Monitoring code	Monitoring name	Range	Unit	Communication address
Un326	Fault code history 7	0~0xFFFF	-	0xE326
Un327	Fault code history 8	0~0xFFFF	-	0xE327
Un328	Fault code history 9	0~0xFFFF	-	0xE328
Un329	Fault code history 10	0~0xFFFF	-	0xE329
Un330	Fault time history 1	0~0xFFFFFFFF	100ms	0xE330
Un331	Fault time history 2	0~0xFFFFFFFF	100ms	0xE331
Un332	Fault time history 3	0~0xFFFFFFFF	100ms	0xE332
Un333	Fault time history 4	0~0xFFFFFFFF	100ms	0xE333
Un334	Fault time history 5	0~0xFFFFFFFF	100ms	0xE334
Un335	Fault time history 6	0~0xFFFFFFFF	100ms	0xE335
Un336	Fault time history 7	0~0xFFFFFFFF	100ms	0xE336
Un337	Fault time history 8	0~0xFFFFFFFF	100ms	0xE337
Un338	Fault time history 9	0~0xFFFFFFFF	100ms	0xE338
Un339	Fault time history 10	0~0xFFFFFFFF	100ms	0xE339

12 Fault Code and Countermeasures

12.1 Fault Code

Fault code	Fault type	Solutions	Alarm category
Er.020	Abnormal parameter and check	<ol style="list-style-type: none"> 1. Enter the parameters again after initializing parameter settings. 2. Write the power level of the driver to 0 first, and then write the correct power level. Note: Remember to perform the current detection correction, analog input correction and bus voltage correction after writing the power level. 3. servo driver failure, replace the servo drive. 	Category 1
Er.021	Parameter formatting exception (inconsistent version number)	<ol style="list-style-type: none"> 1. Perform a soft reset. If the fault is still reported, write the driver's power level to 0 and then write the correct power level. Note: Remember to perform the current detection correction, analog input correction and bus voltage correction after writing the power level. 2. servo driver failure and replace the servo drive. 	Category 1
Er.022	Abnormal system and check	<ol style="list-style-type: none"> 1. Perform a soft reset. If the fault is still reported, write the driver's power level to 0 and then write the correct power level. Note: Remember to perform the current detection correction, analog input correction and bus voltage correction after writing the power level. 2. servo driver failure and replace the servo drive. 	Category 1
Er.030	Abnormal detection in main circuit	<ol style="list-style-type: none"> 1. Servo driver fails, replace the servo driver. 	Category 1
Er.040	Abnormal parameter setting	<ol style="list-style-type: none"> 1. Check whether the changed parameters are out of range. 2. Check if the setting of electronic gear ratio is within the setting range (electronic gear ratio: 0.001 ~ 16777216/1000). 3. Check whether the servo drive and servo motor capacity match. 4. I/O terminal definition repeat. 	Category 1
Er.041	Abnormal frequency division pulse output setting	According to the number of encoder bits, the number of encoder frequency division pulses is set to an appropriate value, see the specification.	Category 1
Er.042	Abnormal parameter combination	<ol style="list-style-type: none"> 1. Make the setting value of electronic gear ratio within the setting range. 2. make the program JOG settings related to logic. 	Category 1
Er.044	Abnormal setting of loop parameters	<ol style="list-style-type: none"> 1. Set the half closed loop / full closed loop parameters correctly. 	Category 1
Er.050	Unmatched drive and motor capacity	<ol style="list-style-type: none"> 1. check if the driver power and motor power are correct. 2. replace the drive or motor so that it is within a reasonable range. 	Category 1
Er.051	Alarm caused by product technical support failure	<ol style="list-style-type: none"> 1. Connect the function modules can not be supported by the product, please select the matching combination. 	Category 1
Er.080	Abnormal distance setting corresponding to unit pulse of	<ol style="list-style-type: none"> 1. Correctly set the distance corresponding to the unit pulse of the encoder. 	Category 1

	encoder		
Er.08A	Abnormal resolution setting of position sensor	1. Set the resolution of position sensor correctly.	Category 1
Er.0B0	Invalid servo ON command alarm	Re-power on or perform a soft reset.	Category 1
Er.100	Over-current fault	1. Check whether the motor phase sequence is wrong. 2. Check whether the motor is damaged and use a multimeter to measure whether U/V/W is short together. 3. Check the motor encoder angle is correct. 4. Monitor the UV phase current sampling AD value in the disabled state through a virtual oscilloscope to determine whether it is a driver hardware current sampling fault. Normally, it is near zero.	Category 1
Er.300	Braking resistor failure	1. Correctly wire the external regenerative resistor. 2. After troubleshooting the wiring, it may be a servo drive problem, replace the servo drive.	Category 1
Er.320	Regeneration overload	1. Check whether the bus voltage of the driver is within a reasonable range when it is not enabled. If the bus voltage is detected incorrectly, there is a possibility of accidental braking or accidental protection. 2. Confirm the brake resistor wiring is correct; see the instructions for details. 3. According to the load situation, consider the current choice of braking resistor is appropriate; see the braking resistor selection rules for details. 4. If the wiring is correct, and the braking resistor is selected properly, and the operation still reports regenerative overload, you can monitor whether there is a small drop when the bus voltage reaches the braking point during operation by the host computer or the keyboard. If the bus voltage reaches the braking point and it still rises smoothly, it can be judged that the brake pipe is damaged. 5. If the fault is reported in the last operation, run after waiting for a while after powering on.	Category 2
Er.330	Main circuit power wiring error	1. Connect the main circuit power cord correctly.	Category 1
Er.400	Over-voltage	1. When the power supply voltage is not enabled, measure the power supply voltage at the same time monitor whether the bus voltage (Un140) is 1.414 times of the input power voltage (AC RMS). If the deviation is large, it can be determined as bus voltage detection hardware failure. 2. Measure the power supply voltage. If the power supply voltage is adjustable, adjust the power supply voltage within the product specification range. If it is not adjustable and the power supply voltage is in an unstable state, you may consider installing a voltage regulator. 3. Consider the operating conditions and load, determine the brake resistor selection is reasonable (whether the resistance is too large), if the overvoltage caused by frequent acceleration and deceleration, you may consider replacing the brake resistor. 4. there may be brake pipe damage, check the brake pipe. 5. Make sure to guarantee that the motor is running at a tolerable moment of inertia ratio and mass ratio. 6. servo drive failure, replace the servo drive.	Category 1

Er.410	Under-voltage	<ol style="list-style-type: none"> 1. Check whether the power input terminal line is connected. 2. When the power supply voltage is not enabled, measure the power supply voltage at the same time monitor whether the bus voltage (Un140) is 1.414 times of the input power voltage (AC RMS). If the deviation is large, it can be determined as bus voltage detection hardware failure. 3. Measure the power supply voltage. If the power supply voltage is adjustable, adjust the power supply voltage within the product specification range. 4. Measure the power supply voltage. If the power supply voltage is in an unstable state, you may consider installing a voltage regulator. 5. If the power capacity is adjustable, you can advise customers to increase in power capacity. 	Category 2
Er.42A	Motor over temperature	<ol style="list-style-type: none"> 1. Reduce motor load. 2. Strengthen motor heat dissipation. 3. Check the motor over temperature signal circuit. 	Category 1
Er.510	Over-speed	<ol style="list-style-type: none"> 1. Check whether there is any problem with the motor wiring and whether the UVW three-phase connection is reversed. 2. Confirm that the encoder connection is abnormal. 3. Check if the maximum speed setting in the motor parameters is correct. 4. Check whether the input command exceeds the over-speed value. 5. Reduce the servo gain or set a certain smoothing time. 	Category 1
Er.511	Divided pulse output speed	<ol style="list-style-type: none"> 1. Reduce the number of divided output pulses per revolution (Pn070). 2. If the working conditions are allowed, you may reduce the motor speed. 	Category 1
Er.520	Vibration alarm	<ol style="list-style-type: none"> 1. If the working conditions are allowed, you may reduce the motor speed or reduce the speed loop gain. 2. correctly set the rotary inertia ratio. 3. properly set the vibration detection value (Pn187) and vibration detection sensitivity (Pn186). 	Category 1
Er.550	Abnormal maximum speed setting	Set the maximum speed setting correctly	Category 1
Er.710	Overload (instantaneous maximum load)	<ol style="list-style-type: none"> 1. Check if the motor is stalled during operation. 2. Check whether there is any problem with the motor wiring (phase sequence, connection) and encoder wiring. 3. consider the operating conditions and load and determine if the driver or motor selection is reasonable. 4. Observe whether there is large vibration in the running process of the motor. If there is a large noise, adjust the gain parameter to eliminate noise or jitter. At the same time, you can use the virtual oscilloscope to monitor whether the motor output torque is abnormal or not. 	Category 2
Er.720	Overload (continuous maximum load)	<ol style="list-style-type: none"> 1. Check whether there is any problem in the motor wiring (phase sequence and connection) and encoder wiring. 2. consider the operating conditions and load and determine the driver or motor selection is reasonable. 3. Observe whether the motor has large jitter during operation. If there is a huge noise, adjust the gain parameter to eliminate noise or jitter. Also, use a virtual oscilloscope to monitor whether the motor output torque is abnormal. 	Category 1

Er.730	DB overload 1	<ol style="list-style-type: none"> 1. The load is too heavy when the machine stops that cause the overload of DB resistor and you could try to reduce the operating speed or reduce the load. 2. check whether the motor is driven by external force. 3. according to customer needs, re-evaluate whether it needs to pass the DB mode requirements during the shutdown, if you do not need, you can choose other ways to stop. 4. If the fault is reported in the last operation, run after waiting for a while after powering on. 	Category 1
Er.731	DB overload 2	<ol style="list-style-type: none"> 1. Reduce the command speed of servo motor. 2. Reduce the moment of inertia ratio. 3. Servo driver problem, replace servo. 	Category 1
Er.740	Inrush current limiting resistance fault	<ol style="list-style-type: none"> 1. The servo driver is faulty. Replace the servo driver. 	Category 1
Er.7A0	Heat sink over-heat	<ol style="list-style-type: none"> 1. Check whether the air duct is blocked and the fan is damaged with a fan drive. 2. Check the installation conditions of the driver, whether the heat dissipation condition is good or not and increase the heat dissipation condition of the driver as much as possible. 3. Check the drive load conditions, if the load is too heavy, you can suggest that customers replace a high-power segment of the drive. 4. If possible, reduce the driver carrier frequency. 	Category 2
Er.7AA	Abnormal temperature of control board	<ol style="list-style-type: none"> 1. Improve the installation condition of servo driver and reduce the ambient temperature. 2. Reconfirm the load conditions and operation conditions. 3. Servo driver failure, replace the servo driver. 	Category 1
Er.7AB	The fan inside the drive does not turn	<ol style="list-style-type: none"> 1. Is there any foreign matter blocking the fan. 2. Servo driver failure, replace servo driver. 	Category 1
Er.810	Abnormal encoder backup	<ol style="list-style-type: none"> 1. Check the multi-turn encoder battery power condition. 2. Perform multi-turn encoder clear operation. 	Category 1
Er.830	Battery under-voltage	Replace multi-turn encoder battery.	Category 1
Er.840	Encoder data is abnormal	Encoder data is abnormal.	Category 1
Er.850	Encoder overspeed	Encoder overspeed.	Category 1
Er.860	Encoder temperature is high	<ol style="list-style-type: none"> 1. Reduce the motor load rate. 2. Strengthen the heat dissipation effect of the motor. 	Category 1
Er.900	CANopen node protection failure	<ol style="list-style-type: none"> 1. Check if the slave is offline. 2. Check whether the node protection time setting is correct. 	Category 1
Er.901	CANopen heartbeat detection timeout	<ol style="list-style-type: none"> 1. Check if the host is offline. 2. Check whether the heartbeat detection time matches the host heartbeat production time. 	Category 1
Er.BF4	Hardware over-current	Unplug the power cable and turn on the servo unit again. If an alarm still occurs, the servo unit may be malfunctioning, and then you could replace the servopack. If not, confirm whether it is power line or motor failure.	Category 1

Er.C10	Out of control alarm	<ol style="list-style-type: none"> 1. Check if the motor wiring is normal. 2. Check if the motor and encoder are normal. 3. Re-connect the servo drive power, if an alarm still occurs, it may be a servo drive failure. 	Category 1
Er.C90	Encoder communication failure: line-broken	<ol style="list-style-type: none"> 1. Use multimeter to test every signal line of the encoder line and see if signal lines break. 2. Check the encoder line model and confirm the model is correct. 3. Check the length of the encoder line and the encoder line can not be too long. 4. It may be caused by interference, try to ground the driver or wire the encoder around the magnetic ring. 5. check the motor group parameters and confirm the motor is correct. 6. If you already exclude various reasons and the servo driver may malfunction, then you could consider replacing the servo unit. 	Category 1
Er.C91	Abnormal encoder communication position data acceleration		Category 1
Er.CA0	Abnormal encoder parameters		Category 1
Er.D00	Excessive position deviation	<ol style="list-style-type: none"> 1. Set the appropriate position deviation excessive alarm value. 2. Check whether the encoder cable and motor cable are connected properly. You can use the hand to rotate the motor and monitor whether the Un003 (rotor relative Z pulse position) varies between 0 and 16777216 (24-bit encoder). 3. Calculate the pulse frequency input and acceleration planning and check if the electronic gear ratio setting is reasonable. 4. Determine whether the relevant parameters are reasonable. For example: you could check the torque limit, speed limit, inertia ratio, position gain, speed gain is too small or the position filter is too large, etc. 5. Calculate if the motor selection is too small or the acceleration and deceleration are too slow that cause huge position deviation. 	Category 1
Er.D01	Excessive position deviation during servo ON	Set correct value of Pn267 (overrunning position deviation when servo is ON).	Category 1
Er.D02	Excessive position deviation alarm caused by speed limit during servo ON	Set correct Maximum position deviation threshold (Pn264) or set correct speed limit value (Pn270) during servo ON.	Category 2
Er.D10	Excessive deviation between motor and load position	<ol style="list-style-type: none"> 1. Confirm the rotation direction of the motor and the installation direction of the external encoder. 2. Check the mechanical installation. 3. Set the parameter Pn250 to the correct value. 	Category 2

12.2 Warning Code

Warning code	Type	Solutions
AL.900	Excessive Position deviation warning	1. Correctly set relevant parameters such as gear ratio, gain, position filtering, torque limit, etc.
		2. confirm the encoder line motor wiring is correct.
		3. If you already exclude various reasons, the servo driver may malfunction and you could consider replacing the servo unit.

AL.901	Excessive position deviation warning during servo ON	Set correct excessive position deviation value during servo ON.
AL.910	Overload warning	1. Check if there is any problem of the motor wiring and encoder wiring.
		2. Incorrect motor or driver selection.
AL.911	Vibration warning	1. Reduce the motor speed or reduce the speed loop gain.
		2. Set the moment of inertia ratio correctly.
AL.920	Regeneration overload warning	1. Set the power supply voltage within the specification range.
		2. Set resistance value and capacity correctly.
		3. Replace the servo drive because of servo driver failure.
AL.921	DB overload warning	1. Reduce the servo motor command speed.
		2. Reduce the rotary inertia ratio.
		3. Replace the servo drive because of servo driver failure.
AL.930	Battery under-voltage warning	Replace the battery.
AL.941	Parameter change warning needed to re-power off	Power down the drive before restart it.
AL.971	Under-voltage warning	1. Adjust the AC/DC power supply voltage to the product specifications.
		2. increase the power capacity.
AL.9A0	Servo overtravel	1. Connect the overtravel signal correctly.
		2. Confirm the accuracy of the operating instructions of the host computer device.

13 Communication

13.1 Communication Introduction

Servo driver can support RS485, CANopen bus type, EtherCAT bus type, MECHATROLINK-II bus type. Here we mainly introduce the related content of general model RS485 communication. Other communication needs to refer to the special communication manual. 485 communications can realize the following functions.

- a) Read and write servo driver function code related parameters
- b) Monitor the working status of the servo drive
- c) Constitute a multi-axis control system
- d) Operate the servo assist function

13.2 RS485 Communication Protocol Description

Provide RS485 communication interface, the wiring is detailed in CN6, and the master-slave communication is carried out by the international standard Modbus communication protocol. Users can achieve centralized control through PC/PLC, control PC, etc. to suit specific application requirements.

The Modbus serial communication protocol defines the frame content and usage format for asynchronous transmission in serial communication. These include: host polling and broadcast frame, slave response frame format; host organization frame content includes: slave address (or broadcast address), execution commands, data and error check. The response of the slave is also the same structure, including: action confirmation, return data and error check. If the slave encounters an error while receiving a frame, or fails to complete the action requested by the host, it will organize a fault frame as a response to the host.

The communication protocol is an asynchronous serial master-slave Modbus communication protocol. Only one device (host) in the network can establish a protocol (called "query/command"). Other devices (slave) can only respond to the host's "query/command" by providing data, or according to the host's "query/command". The host here refers to a personal computer (PC), an industrial control device or a programmable logic controller (PLC), etc. The slave refers to a servo drive or other control device having the same communication protocol. The host can communicate with a slave separately and broadcast information to all slaves. For a host "query/command" that is accessed separately, the slave must return a message (called a response). For the broadcast message sent by the host, the slave does not need to feed back the response message to the host.

13.3 Communication Frame Structure

Modbus only supports RTU transmission mode. The user can configure the serial communication parameters (baud rate, check mode, etc.).

Each 8Bit byte in the message frame contains two 4Bit hexadecimal characters.

Start bit	Device address	command	data	CRC check	Terminator
T1-T2-T3-T4	8Bit	8Bit	N 8Bit	16Bit	T1-T2-T3-T4

In this mode, the message transmission starts at least at a pause interval of 3.5 characters. During transmission, the network device continuously detects the network bus, including the pause interval. When the first field (address field) is received, the corresponding device decodes the next transmitted character, and if there is a pause of at least 3.5 characters, it indicates the end of the message.

In RTU mode, the entire message frame must be transmitted as a continuous stream. If there is a pause time of more than 1.5 characters before the frame is completed, the receiving device will refresh the incomplete message and assume that the next byte is the address of a new message. area. Similarly, if a new message begins with the previous message in less than 3.5 character times, the receiving device will consider it a continuation of the previous message. If the above two situations occur during the transmission, the CRC check will inevitably generate an error message and feed back to the sender device.

13.4 Command Code and Communication Data Description

In the communication command, the data address read and written is the hexadecimal number of the parameter name, for example, the address of the inertia ratio Pn100 is 0x0100.

(1) Command code: 03H

Function: Read N words (Word can read up to 16 words in succession).

For example, if the servo drive with the slave address 01H reads the address e003 and reads two consecutive words, the structure of the frame is described as follows:

Host command information:

START	T1-T2-T3-T4 (3.5 bytes of transmission time)
ADDR	01H
CMD	03H
Read start address high	e0H
Read start address low	03H
high number of data (in word)	00H
low number of data is (in word)	02H
CRC CHK low bit	03H
CRC CHK high bit	CBH
END	T1-T2-T3-T4 (3.5 bytes of transmission time)

The slave responds to the message:

START	T1-T2-T3-T4 (3.5 bytes of transmission time)
ADDR	01H
CMD	03H
Number of bytes	04H

The high content of the starting data address 03F 2H	3AH
Content status of the starting data address 03F 2H	9AH
The content of the second data address 03F 3H is high	00H
The lower content of the second data address 03F 3H	05H
CRC CHK low bit	16H
CRC CHK high bit	C7H
END	T1-T2-T3-T4 (3.5 bytes of transmission time)

(2) Command code: 10H

Function: Write N words (Word), $N \geq 2$.

For example, write 100 to the 0100H address of the slave address 01H servo drive and 400 to the 0101H address of the slave address 01H servo drive.

The structure of the frame is described as follows:

Host command information:

START	T1-T2-T3-T4 (3.5 bytes of transmission time)
ADDR	01H
CMD	10H
Write data address high	01H
Write data address low	00H
The number of data is high (in word)	00H
Number of data status (calculated in word)	02H
Number of bytes	04H
The first word high of the data content	00H
The first word of the data content is low	64H
The second word high of the data content	01H
The second word of the data content is low	90H
CRC CHK low bit	BEH
CRC CHK high bit	1CH
END	T1-T2-T3-T4 (3.5 bytes of transmission time)

The slave responds to the message:

START	T1-T2-T3-T4 (3.5 bytes of transmission time)
ADDR	01H
CMD	10H
Write data start address high	01H
Write data start address low	00H
The number of data is high (in word)	00H
Number of data status (calculated in word)	02H
CRC CHK low bit	40H
CRC CHK high bit	34H
END	T1-T2-T3-T4 (3.5 bytes of transmission time)

13.5 Communication Frame Error Check Mode:

The error check mode of the frame mainly includes two parts of the check, that is, the bit check of the byte (odd/even check) and the entire data check of the frame (CRC check or LRC check).

13.5.1 Byte Bit Check

Users can choose different bit verification methods as needed, or they can choose no parity, which will affect the parity bit setting of each byte.

The meaning of even parity: an even parity bit is added before data transmission to indicate whether the number of "1" in the transmitted data is odd or even. When it is even, the check position is "0", otherwise it is set. It is "1" to keep the parity of the data unchanged.

The meaning of the odd check: an odd parity bit is added before the data transmission to indicate whether the number of "1" in the transmitted data is odd or even. When it is odd, the check position is "0", otherwise it is set. It is "1" to keep the parity of the data unchanged.

For example, you need to transfer "11001110", the data contains 5 "1", if you use even parity, its even parity bit is "1", if you use odd parity, its odd parity bit is "0", transmission In the case of data, the parity bit is calculated at the position of the check bit of the frame, and the receiving device also performs parity check. If the parity of the accepted data is found to be inconsistent with the preset, it is considered that the communication has an error.

13.5.2 CRC Check Method --- CRC (Cyclical Redundancy Check)

Using the RTU frame format, the frame includes a frame error detection field calculated based on the CRC method. The CRC field detects the contents of the entire frame. The CRC field is two bytes and contains a 16-bit binary value. It is calculated by the transmission device and added to the frame. The receiving device recalculates the CRC of the received frame and compares it with the value in the received CRC field. If the two CRC values are not equal, the transmission has an error.

The CRC is first stored in 0xFFFF, and then a procedure is called to process the consecutive 6 or more bytes in the frame with the values in the current register. Only the 8Bit data in each character is valid for the CRC, and the start and stop bits as well as the parity bit are invalid.

During the CRC generation process, each 8-bit character is individually different from the register contents (XOR), and the result moves to the least significant bit direction, and the most significant bit is padded with 0. The LSB is extracted and detected. If the LSB is 1, the register is individually or different from the preset value. If the LSB is 0, it is not performed. The entire process is repeated 8 times. After the last bit (bit 8) is completed, the next octet is individually different from the current value of the register. The value in the final register is the CRC value after all the bytes in the frame have been executed.

This calculation method of CRC adopts the international standard CRC check rule. When editing the CRC algorithm, the user can refer to the CRC algorithm of the relevant standard to write a CRC calculation program that truly meets the requirements.

13.6 Error Message Response

When the slave responds, it uses the function code field and the fault address to indicate whether it is a normal response (no error) or an error (called an objection response). For a normal response,

the slave responds with the corresponding function code and data address or sub-function code. In response to the objection, the device returns a code equivalent to the normal code, but the first position is logic 1.

For example, if a message sent by a master device to a slave device requires reading a set of servo driver function code address data, the following function code will be generated:

0 0 0 0 0 1 1 (hex 03H)

For a normal response, the slave responds with the same function code. In response to the objection, it returns:

1 0 0 0 0 1 1 (hexadecimal 83H)

In addition to the modification of the function code due to an objection error, the slave device will respond with a one-byte exception code, which defines the cause of the exception.

After the master application responds with an objection, the typical process is to resend the message or make a command change for the corresponding failure.

Modbus exception code		
Code	Name	Meaning
01H	Illegal function	When the function code received from the host computer is an operation that is not allowed, this may be because the function code is only applicable to the new device and is not implemented in the device; at the same time, the slave may also process the request in an error state.
02H	Illegal data address	For the servo drive, the request data address of the upper computer is an unallowable address; in particular, the combination of the register address and the transmitted byte number is invalid.
03H	Illegal data value	The received data value exceeds the range of the address parameter, causing the parameter change to be invalid.
11H	Parity error	When the RTU format CRC check bit or the ASCII format LRC check bit is different from the check calculation number of the lower computer in the frame information sent by the host computer, the check error information is reported.

14 Host Debugging Instruction

14.1 System Requirements

14.1.1 System Configuration



1. When the user uses the software for the first time, please confirm whether the NET3.5 and NET4.0 frameworks are installed. This is a prerequisite; otherwise the software cannot be opened. But for Win7 and above operating systems, there is no need to install NET 3.5 and NET 4.0 frameworks.
2. The host computer system currently supports USB communication debugging.
3. The system only supports servo SD700 series servo product debugging.
4. Verify that the “Use FIPS-compliant algorithms for encryption” option is set to disabled (Control Panel - Administrative Tools - Local Security Policy - Security Options - Use FIPS-compliant algorithms for encryption - disabled).

14.1.2 Connection Configuration

The servo driver is connected to the computer through the communication connector, and the interface type is USB. Basic configuration:

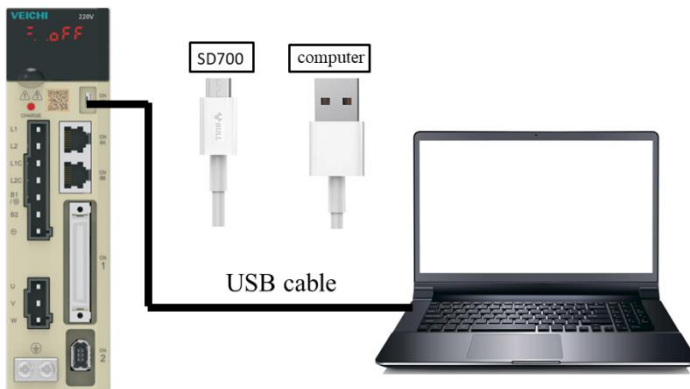
- Anti-jamming Android micro phone data cable.



1. Connection between PC and SD700 servo drive via Android micro mobile phone data cable.
2. Click My Computer - Manage - Device Manager and find  Other devices and find  VEICHI SD700 SERIES.
3. Right-click and select “Update Driver”, select “Browse calculations to find driver software”.
4. Manually select the upper machine installation package file for driver installation.

5. Then the device manager  appears, indicating that the installation has been successful.

14.2 Main Interface

The main interface includes menu bar, toolbar, function display area, information bar, status bar and other functions, as shown in the following figure;

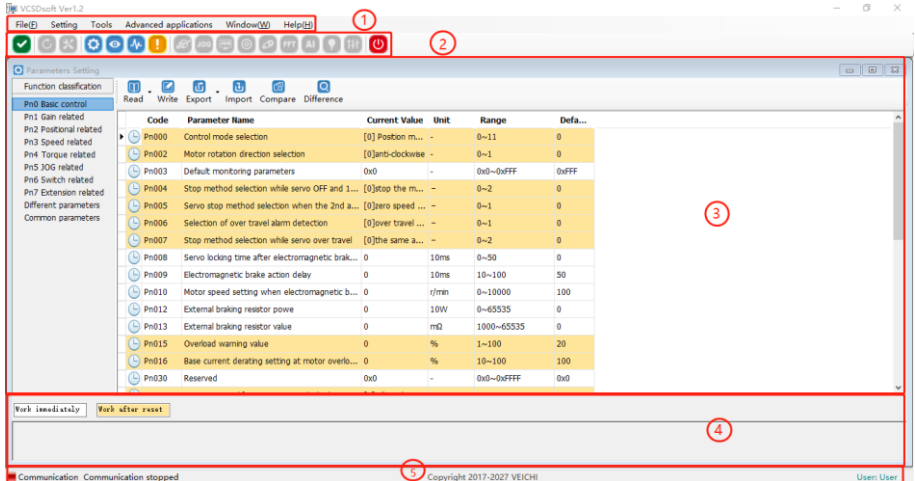

(1). Menu bar

The menu bar includes functions such as files, settings, tools, advanced applications, windows, and help.

[File]: Open and exit the system.

[Settings]: user rights, service personnel rights, developer rights.

[Tools]: parameter settings, real-time monitoring, digital oscilloscope, fault information, screenshots and other functions.

[Advanced applications]: inertia identification, JOG, program JOG, homing, mechanical characteristics, FFT analysis, single parameter adjustment, intelligent adjustment, offset adjustment.

[Window]: Cascading display, horizontal display, vertical display, all off.

[Help]: about;

(2). [Toolbar]

The toolbar includes communication disconnection, communication connection, JOG, program JOG, soft reset, factory reset, parameter setting, monitoring parameters, digital oscilloscope, fault maintenance, screenshot, mechanical characteristics, FFT analysis, intelligent adjustment, offset adjustment, single parameter adjustment, exit and other functions.

(3). Function display area

The function display area is used as a form container to provide sub-window display of reading and writing parameters, monitoring parameters, digital oscilloscope, fault maintenance, and function debugging.

(4). Information columns

[Some parameters] show supplementary explanation.

(5). Status bar

The status bar includes the current communication status and servo work status.

14.3 Features

(1) File

Documents include open, exit, etc.

(2) Turn on

Open function: open the existing file.

Step:

Click the menu bar [File] -> [Open] -> [Select the current system directory folder Test32] -> [Select VCDGSmsyc.vcb file].

(3) Exit

Exit function: Close the current system.

Step:

Click [Exit] in the file column, exit the system, or click [Exit System] on the motor toolbar to exit the system.

(4) Read and write parameters

Read and write parameters include functions such as reading and writing of function codes, import, and export.

Step:

a). Start reading and writing parameters interface:

Click on the menu bar "Tools" -> "Parameter Settings".

b). The pop-up read/write parameters (parameter setting) interface is displayed in the display area, as shown in the following figure:

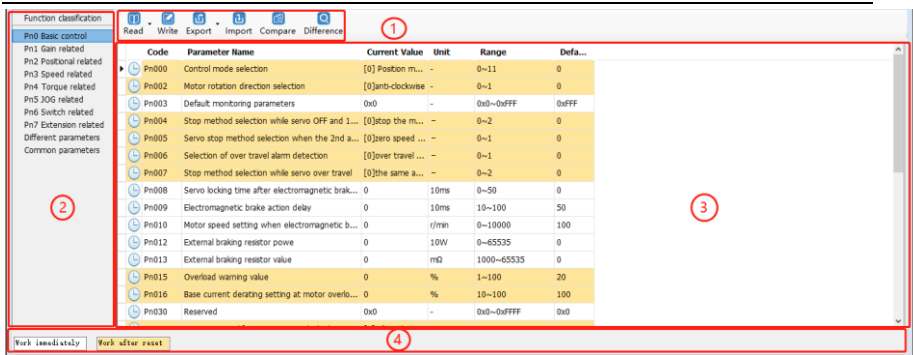

i-Toolbar

The toolbar includes reading the current page function code, reading all page function codes, writing function codes to EERPOM, exporting the current page function code, exporting all function codes, importing function codes in batches, comparing the differences of two file parameters and finding out modified parameters, as shown below:



ii-Multi page

Each page is displayed in different functional groups. At the same time, common parameters and different parameter pages are added to facilitate viewing of function codes.

iii-function code

The function code is a specific function and provides relevant information such as the current state, name, current value, unit, default value, minimum value, maximum value, and attribute, etc. When a row is clicked, the corresponding function code comment is provided as below:

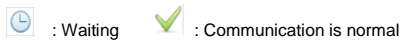

iv-Information column

Display parameter modification after the effective mode and function code supplementary explanation:

(5) Function code reading

Function code reading can be read individually or in batches.

Step:

- a). Current group read: switch to a group of parameters, left-click on [read] -> select [current group], read the current group parameters.

b). Read all: Left-click on [Read] -> Select [All] to read all parameters and the pop-up dialog box will display the progress of the read function code in the form of a progress bar; as shown in the following figure:

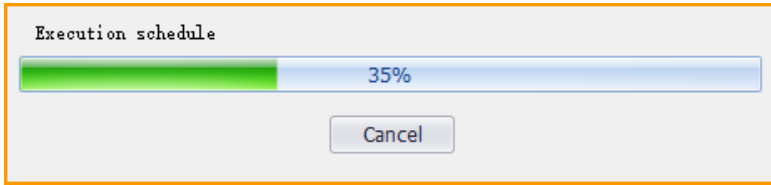

(6) Function code write/import

Function code writing can be individually written.

Step:

a). write individually: select a function code, click on the column corresponding to the current value, click twice in succession, it may enter the editing state, enter the value then click on Enter, the system will automatically send a write command, or directly click [Write] on the toolbar after editing to finish writing the parameters.

b). Steps to import in batches:

Click [Import] → [Select File] -> Click [Import], as shown in the following figure:

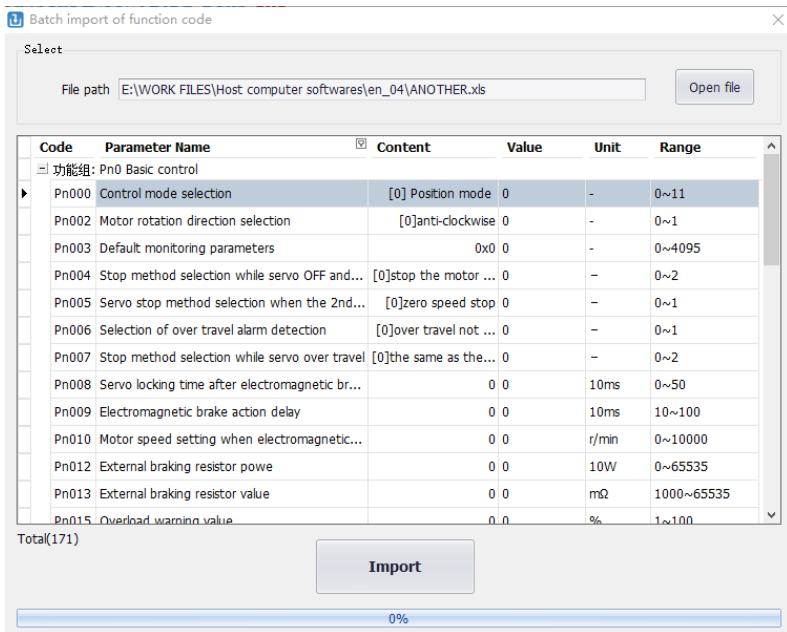

(7) Function code export

Function code export can export current and all function codes:

Step:

Click on the toolbar icon  to select the current group and complete the current group export; or select all to complete the export of all function codes.

(8) Find different function codes

Finding different function codes can find out the modified parameters to facilitate user analysis.

Step:

Click on the toolbar icon  to find out the modified parameters. At the same time, the pop-up dialog box will display the progress in the form of a progress bar as shown in the following figure.

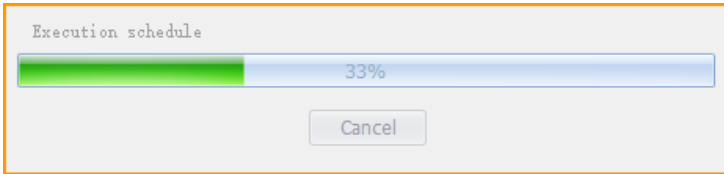

(9) Function code comparison

Compare two sets of exported function codes.

Step:

Click on the toolbar icon , the function code comparison file selection interface appears. Select the source file and the target file respectively then click on [Compare], and the following interface appears. Click on Save to save the two parameters of the two files.

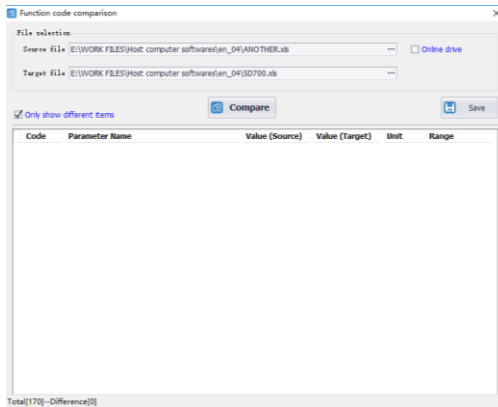

14.4 Real-Time Monitoring

1. Real-time monitoring provides real-time monitoring of monitoring parameters and I/O status, as well as current fault information:

Step:

a). Start the real-time monitoring interface. As shown in the figure below, the monitoring parameters are divided into three groups. The monitoring parameters can be added to the common parameters.

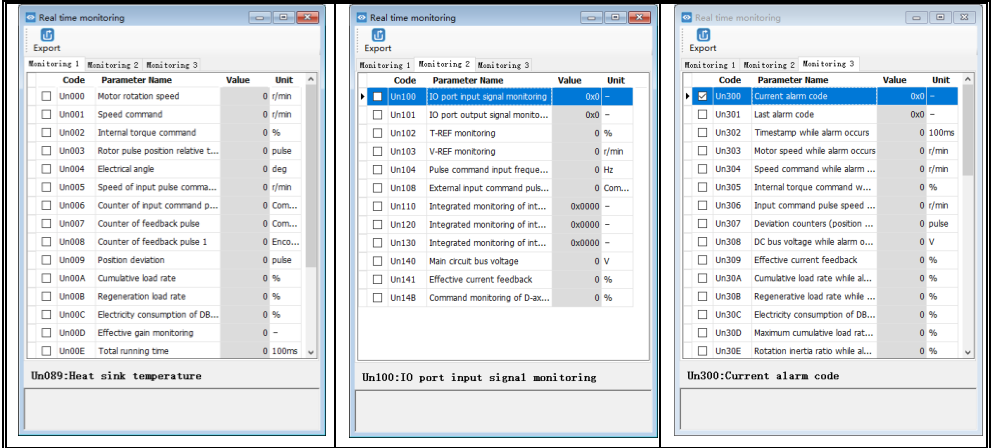

b). Check the monitored parameters and monitor the servo. During the monitoring process, you can also export and save the monitoring content.

2. Monitoring parameter export

The export of monitoring parameters is a way to output and save the monitoring parameters, which can facilitate the customer to save the monitored parameters.

Step:

a). Check the monitored parameters. If you want to export all parameters in the current group, right-click in the monitored parameters area, select All group, and then click Export. Select the save path and save the monitoring data in the EXCEL file format.

14.5 Auxiliary Functions

14.5.1 JOG

The JOG operation is a function to confirm the operation of the servo motor by driving the servo motor at the previously set JOG speed (rotation speed) without connecting the host device. By performing this operation confirmation, it is possible to confirm whether or not the connection to the wire is improper and whether the servo motor has failed.

Step:

- a). Click the icon  on the main interface of the host computer to enter the jog operation interface. As shown in the left figure below, click Start, and then click forward rotation. The servo will execute forward rotation, click Reverse, and the motor will perform reverse rotation.

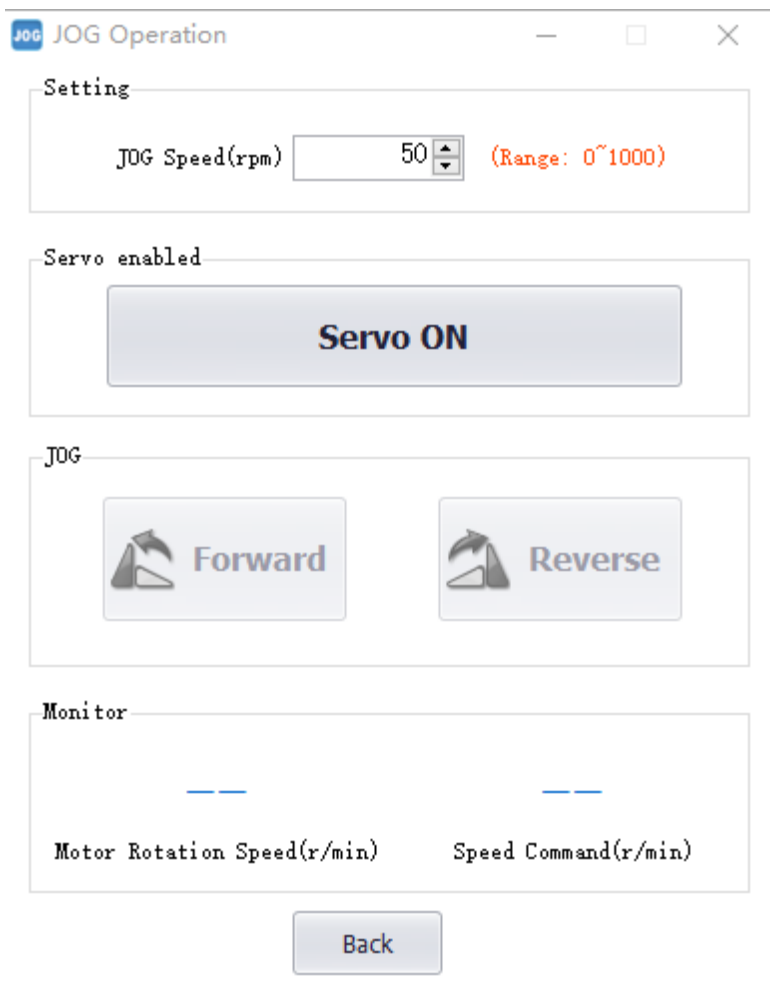

14.5.2 Inertia Identification

The inertia Identification function allows the servo unit to perform automatic operation (forward and reverse reciprocating motions), and estimates the moment of inertia of the load during operation.

Step:

- a). Click [Inertia Identification]→[Next] on the host interface to enter the following interface in the

inertia identification operation process, as shown in the following figure.

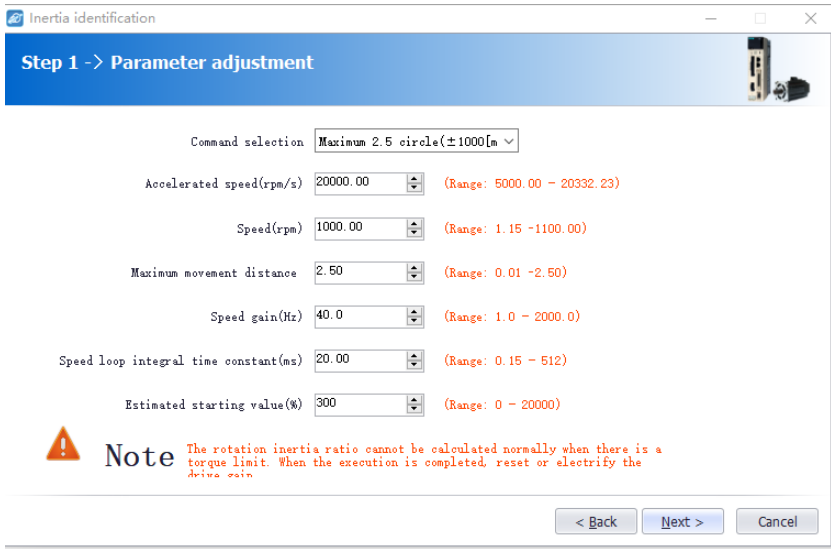

b). As shown in the above figure, set the corresponding parameters according to the actual situation (usually keep the default), and click [Next] → [Write] → [Next] → [Enable] → [Forward] → [Reverse] After the forward rotation is repeated three times, the final inertia identification result is displayed, as shown in the following figure.

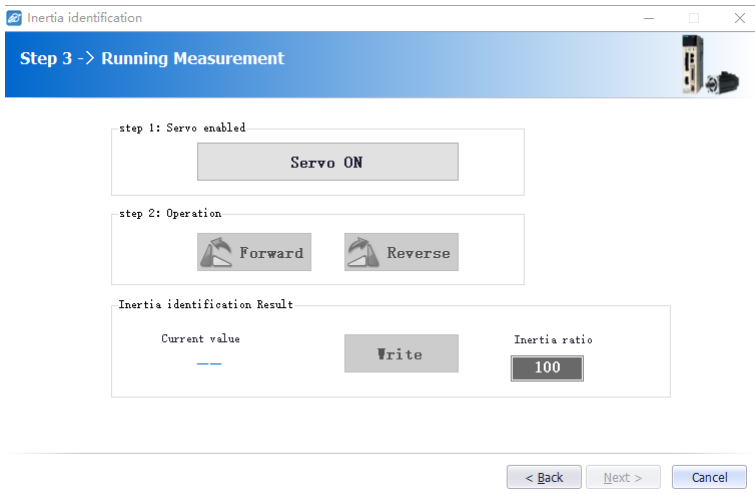

c). Click [Write]→[Next]→[Complete] to finish the inertia recognition process.

14.5.3 Program JOG

The JOG operation of the program refers to the function of executing the continuous operation in the previously set operation mode (moving distance, moving speed, acceleration/deceleration time, waiting time, number of movements). This function is the same as the JOG operation, and the upper apparatus is not connected during the setting. The servo motor operation can be confirmed and a simple positioning operation can be performed.

Step:

- a). Click on  of the main interface of the host computer to enter the program jog operation process, and then click on [Next] to enter the parameter adjustment interface and set related parameters as required. The detailed interface is as shown in the figure below.

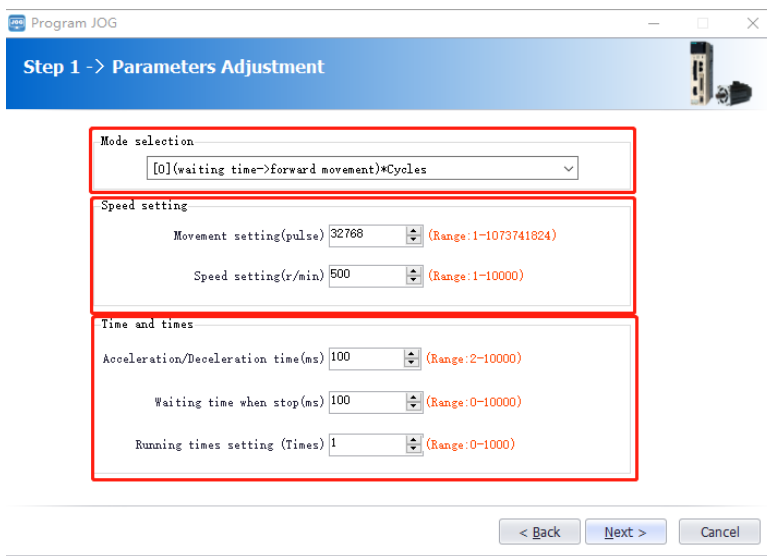

- b). After setting the corresponding parameters, click on [Next] → [Write] → [Next] → [Enable] → [Execution] → [Next] → [Complete]. The program JOG operation process ends.

14.5.4 Mechanical Characteristics

Mechanical analysis characteristics mean that the servo unit performs automatic operation (positive and negative reciprocating motion) without issuing an instruction from the host computer, and the function of estimating the common vibration frequency of the mechanical system during operation is performed.

Step:

- a). Click on  of the main interface of the upper computer to enter the mechanical characteristics analysis operation process, click on [Next] → [Next] to enter the parameter

adjustment interface, and adjust the corresponding parameters according to the actual situation, as shown in the following figure.

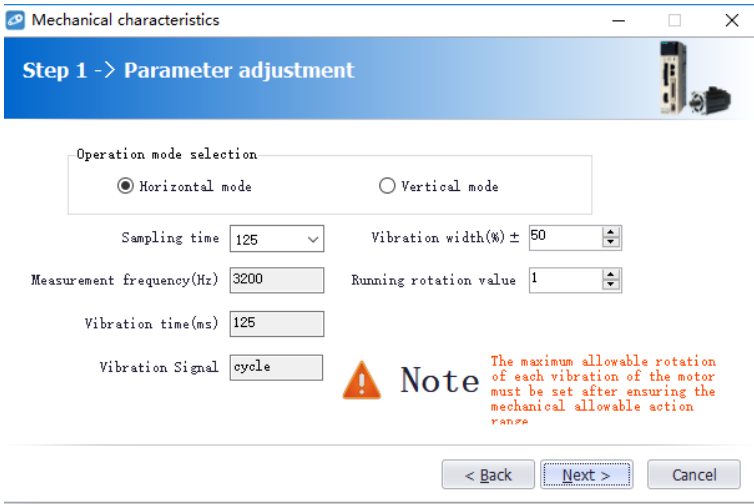

b). Click [Next] → [Write] → [Next] → [Enable] → [Forward] → [Enable] → [Reverse] → [Next] → [Complete] to enter the mechanical properties FFT analysis interface, as shown in the figure below:

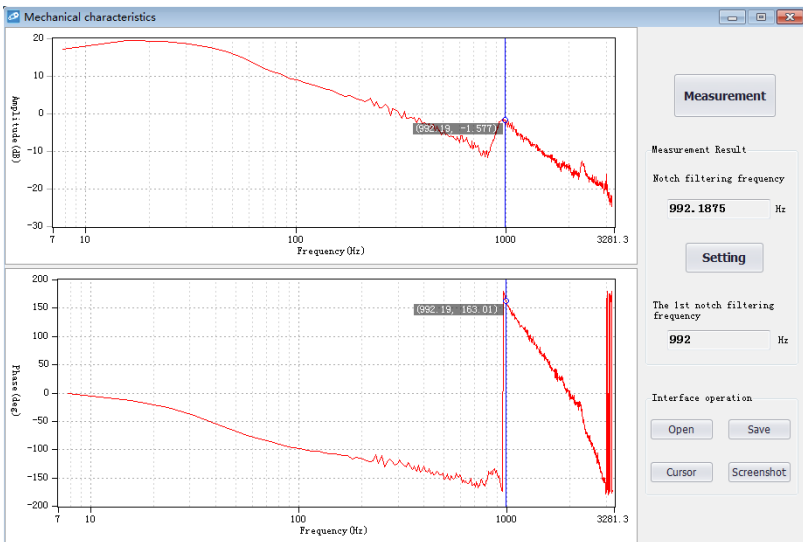

c). From the above figure, you can analyze the frequency, amplitude, and phase of the resonance frequency. Click on [Settings] to set the frequency of the first notch filter. After the setting is completed, the screen is closed. Mechanical properties are completed.

14.5.5 FFT Analysis

EasyFFT transfers the periodic waveform commands from the servo unit to the servo motor and rotates the servo motor slightly for a certain time to cause the vibration of the machine. The servo unit detects the resonance frequency based on the vibration generated by the machine, and then sets the corresponding notch filter according to the resonance frequency. The notch filter effectively removes high-frequency vibrations and noise.

Step:

a). Click on  to enter the FFT measurement interface. Set the command amplitude and rotation direction in the measurement conditions. Click to start measurement and you can measure the frequency of the first notch filter, as shown in the figure below:

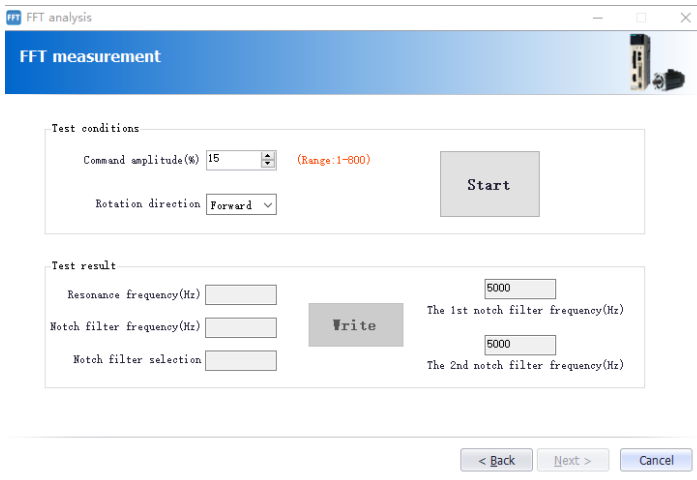

b). Click on [Start] to measure the first notch, and then click on [Write] to write the frequency of the first notch filter.

c). Click on [Start] to measure the second notch, and then click on [Write] to write the second notch filter frequency.

d). Click on [Next] → [Done] to close the operation interface and the FFT analysis is completed.

14.5.6 Bandwidth setting

Bandwidth setting is the method of inputting a speed command or position command from the host device and manually adjusting it while it is running. By adjusting one or two values via bandwidth setting, the relevant servo gain settings can be automatically adjusted.

Bandwidth setting adjusts the following items.

- Gain adjustment (speed loop gain, position loop gain, etc.).
- Filter adjustment (torque command filter, notch filter).
- IF suppression control.

Step:

a). Click  of the main interface of the upper computer to enter the single parameter adjustment prompt interface, click on [Next] to enter the parameter adjustment interface, select the organization selection according to the actual situation, and select the desired mode, as shown in the following figure.

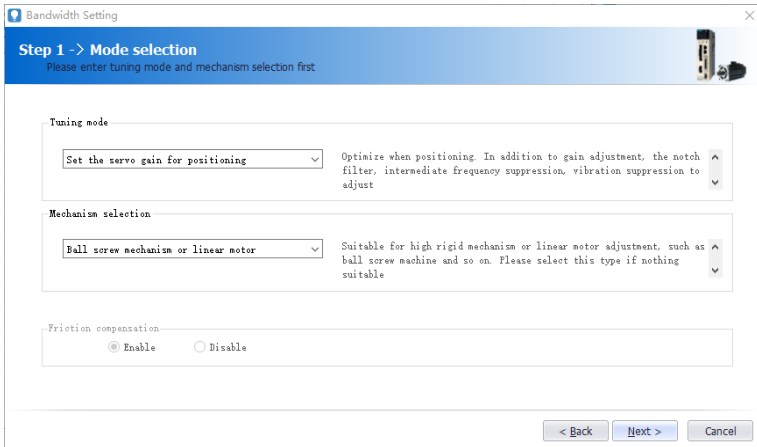

b). Click on [Next] to enter the setting interface of inertia moment ratio and set the inertia ratio (inertia ratio can be obtained through inertia identification function).

c). Click on [Next] to enter the single parameter tuning interface as shown in the following figure.

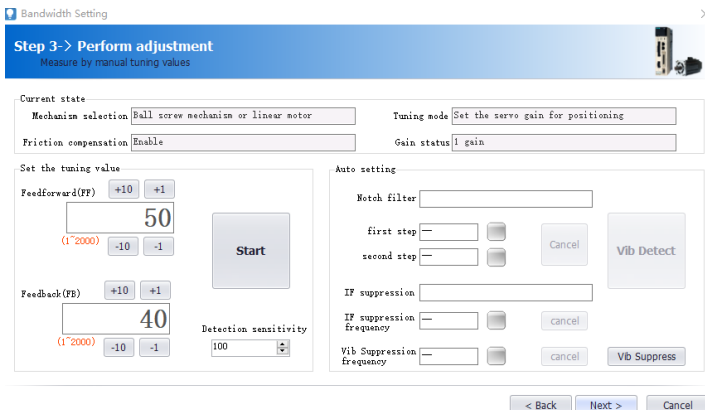

d). Click on [Adjust Start] to tune the tuning value (generally increase). During the process of increasing the tuning value, the servo will vibrate. At this time, vibration detection will be performed automatically. If not, operation can be performed manually, and the tuning value can be set in combination with the figure captured by the digital oscilloscope, or 80% of the tuning value of the motor can be selected as the tuning value. Specific or combined with the actual site requirements for adjustment settings.

e). In the tuning process, when the servo motor is vibrating, it will detect the resonance frequency and the intermediate frequency suppression frequency. After the tuning is completed, click on [Next] to enter the auto tuning completion interface and click on [Finish] to complete the single parameter adjustment operation.

14.5.7 Offset Adjustment

Offset adjustment is divided into two parts:

1: Speed/torque command offset (automatic/manual) adjustment.

2: Motor/current detection signal offset (automatic/manual) adjustment.

Step:

a). Click  on the main interface of the host computer to enter the offset wizard interface. Click on [Next] to enter the offset adjustment function selection interface, select the function you need to adjust, and click on [Next] to enter the adjustment interface.

b). Set the adjustment method, click on [Next], click on [Finish], the offset adjustment screen closes, and the adjustment process ends.

14.5.8 Return to Origin

The origin search is a function that determines the position of the origin pulse (Z phase) of the incremental encoder and stops at this position.

Step:

- a). Click  on the main interface of the host computer to enter the origin setting wizard interface. Click [Next] to enter the execution instruction interface, as shown in the following figure.

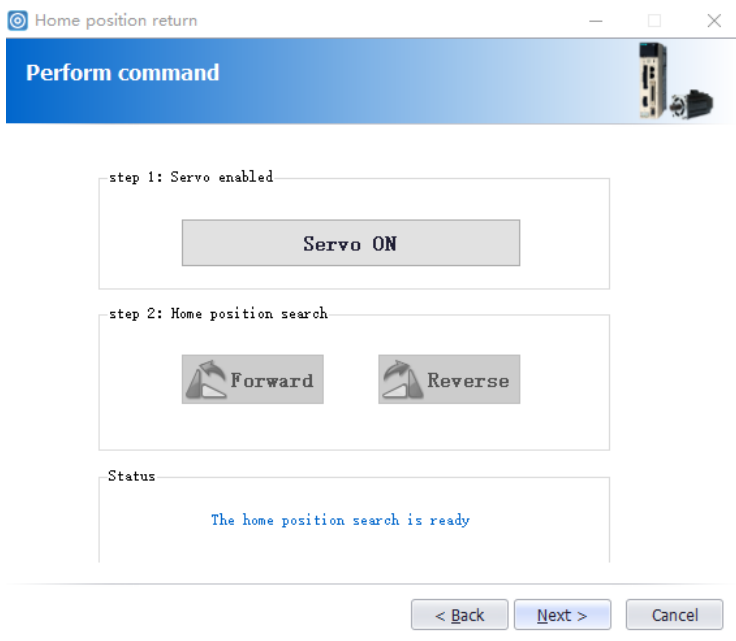

- b). Click [Enable] to enable the servo motor to enter the enable state, and then click [Forward Run] or [Reverse Run] to perform the origin search. After the search is completed, click [Next] to enter the back to origin setting interface and click [Completed] to return to origin operation.

14.5.9 Soft Reset

The function could reset the servo unit from the inside by software. Used to re-power on or reset the alarm after changing the parameter setting. It is also possible to validate the setting without turning the power back on.

Step:

- Click  on the main interface of the host computer to perform a soft reset operation.

14.5.10 Restoring the Factory Value

The function is used to restore the parameter to the factory setting. Parameter initialization should note the problems as bellow:

1. Initialization of the parameter setting value must be performed during the servo OFF and it cannot be executed during the servo ON.
2. For the setting to take effect, the servo unit must be turned on again after the operation.

Steps:

Click  on the main interface of the upper computer to restore the factory value. After the operation is completed, power it on again.

14.5.11 Fault Information

The fault information can display current faults, historical faults, causes of faults, handling measures, information related to faults, and clearing of fault information. Click  to display the following interface.

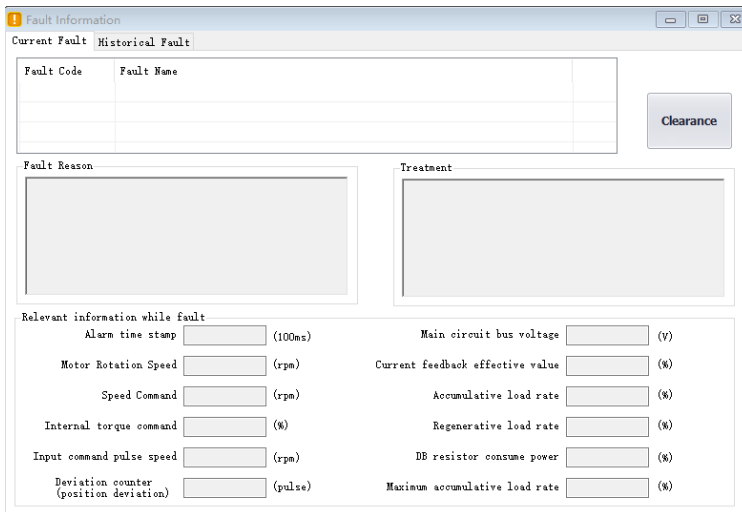

According to the above information, the servo fault is repaired.

14.6 Digital Oscilloscope

Digital oscilloscopes collect data at high speeds and display them graphically to analyze data.

Steps:

a). start the data oscilloscope interface (provide two ways):

Method 1: Click on the main menu of the host computer menu [Tools] -> [Oscilloscope], start the oscilloscope;

Method 2: Click the icon  on the main interface of the host computer to start the oscilloscope.

b). Display data oscilloscope interface, as shown below:

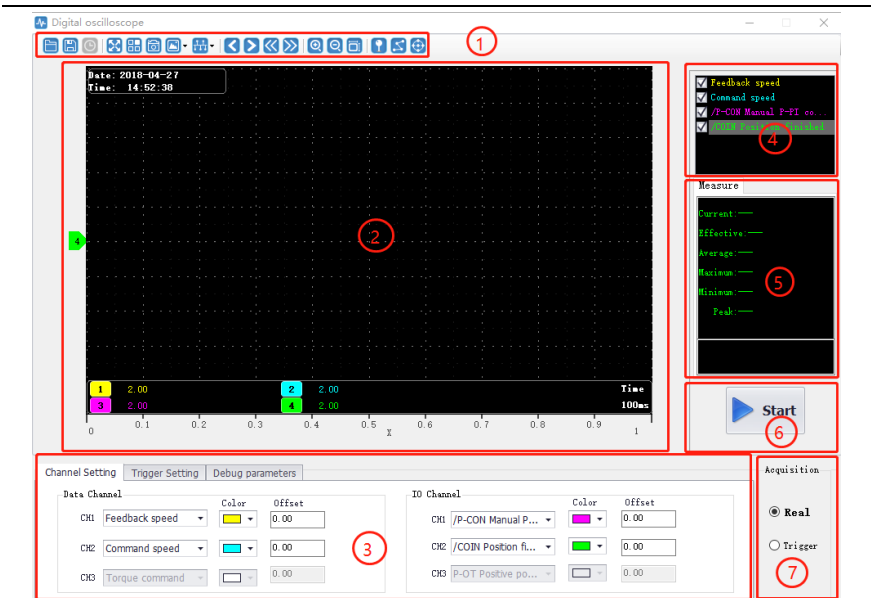

i - Toolbar

The toolbar includes open, save, full screen, style (switch to display background), settings, screenshots, legend, timeline, back, forward, rewind, fast forward, zoom in, zoom out, adaptive, zero position, dot/line, measurement and other functions.

ii - Curve display area

Different curves provide visual display and measurement results for display.

iii - Channel setting and trigger setting

It provides channel-related parameter settings and trigger related parameter settings. Parameter setting includes trigger condition settings and channel settings; data channel detailed functions are as follows.

Data channel	I/O channel
<div style="border: 1px solid gray; padding: 5px;"> <div style="border-bottom: 1px solid gray; height: 20px; margin-bottom: 5px;"></div> <ul style="list-style-type: none"> ▶ Command speed ▲ Feedback speed Torque command Position command speed Command speed before position l... Position command difference Position feedback difference Position error Speed feedforward Torque feedforward Friction compensating torque Vibration deviation control speed Position loop regulator deviation ▼ </div>	<div style="border: 1px solid gray; padding: 5px;"> <div style="border-bottom: 1px solid gray; height: 20px; margin-bottom: 5px;"></div> <ul style="list-style-type: none"> ▶ /S-ON Servo enable ▲ /P-CON Manual P-PI control P-OT Positive position limit N-OT Negative position limit /ALM-RST Alarm clearance /TLC Torque limit selection /SPD-D Internal speed command ... /SPD-A AInternal speed command... /SPD-B Internal speed command s... /C-SEL Control mode switch /ZCLAMP Zero speed clamping /INHIBIT Pulse input inhibit /G-SEL Gain switching ▼ </div>
<div style="border: 1px solid gray; padding: 5px;"> <div style="border-bottom: 1px solid gray; height: 20px; margin-bottom: 5px;"></div> <ul style="list-style-type: none"> Torque command before disturba... ▲ Active gain Main circuit voltage Current detection value Cumulative load rate Regeneration load rate Motor position feedback difference Full closed loop position feedback ... Electric angle VREF ▶ TREF None ▼ </div>	<div style="border: 1px solid gray; padding: 5px;"> <ul style="list-style-type: none"> SEN PULS SIGN CLR Pulse clearance /HWBB1 /HWBB2 ALM Alarm output /COIN Position finished /V-CMP Same speed ▶ /TGON Rotational detection signal /S-RDY Servo ready /CLT Torque limit /VLT Speed limit /BK Brake linkage /WARN Warning output /NEAR Position approach signal /C-PHASE PAO Frequency division output A PBO Frequency division output B PCO Frequency division output C ACON DEN None </div>

iv - Waveform display selection area.

It provides selection and display of desired waveforms.

v - Digital display of measured value.

It provides display of current value, effective value, average value, maximum value, minimum value, peak value, etc.

vi - Record button operation button.

It's used to start and stop recording.



vii - Collection method selection.

It's used to choose the mode of wave recording, real-time and triggered acquisition.



14.6.1 Real-Time Acquisition

Real-time acquisition is displayed in real time in the form of waveforms on the servo operating conditions.

Steps:

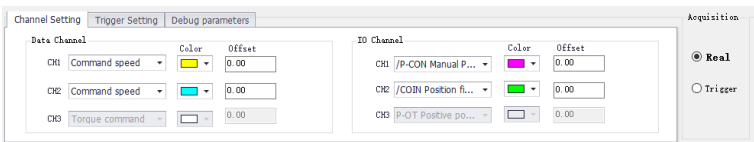
a). Start: Select real-time acquisition mode, set the channel settings, as shown in the figure below, then click the record button , start recording, and the status of the icon changes to .



b). Stop: click on the record button  to stop recording, and the status of the icon changes to .

14.6.2 Trigger Acquisition

The trigger acquisition is based on the trigger condition and the acquisition cycle and makes the servo operation status displayed in the form of a waveform.

Steps:

a). Select the trigger for the acquisition mode. After the data channel and trigger conditions are set, as shown in the following figure, click the record button , which triggers the start of recording.

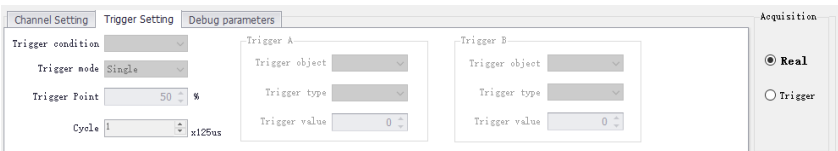

Note: After setting the trigger condition parameters, the terminal receives the trigger condition and will automatically judge according to the conditions.

b). After the waveform to be triggered is received, the waveform will remain in the last state; the record button will change to .

c). If you need to trigger again, you need to start recording again.

14.6.3 Graphic Operations

Graphic operations include X/Y zoom, XY label value, Y axis curve point and point display/hide and measurement, X axis curve point and point display/hide and measurement, curve zoom in/out, curve shift, curve zero adjustment , curve adaptive adjustment, graphics attribute settings and other functions.

X axis cursor

Steps:

- a). Click on the toolbar icon  , the graph will automatically display the two axes of the X-axis, and the upper right corner will automatically display the two axis values corresponding to the X-axis cursor, the difference between the data and real time as shown in the figure below:

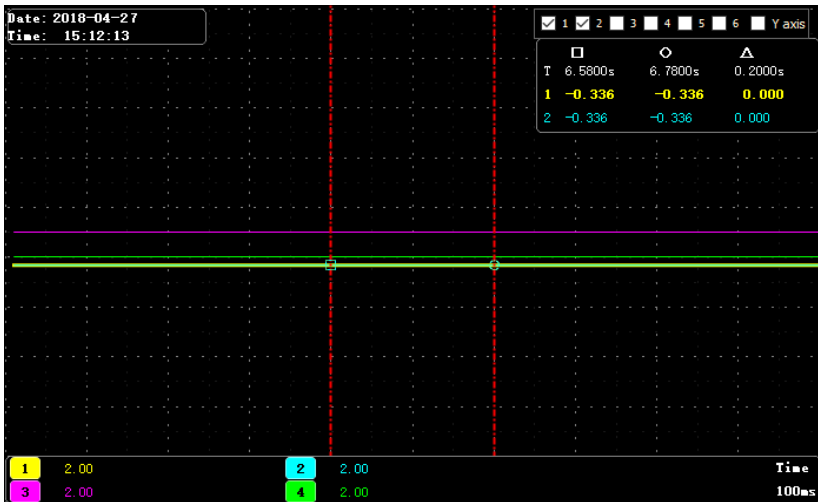

Y axis cursor

The Y-axis has two coordinate axes and functions are similar to the X-axis.

1. Click on the toolbar icon  to check the Y axis. The graph will automatically display the two axes of the Y axis. The two axes of the X axis cursor are automatically displayed in the upper right corner. The data difference between the two axes is shown in the figure below:

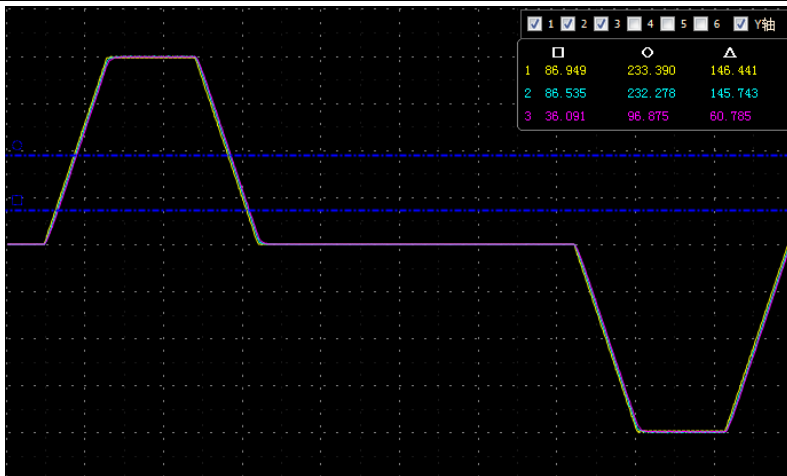

XY digital display

There are multiple axes on the Y axis, which can be selected according to the needs. Through the measurement function, the mouse will display the XY value of the current point in digital form as shown in the following figure.

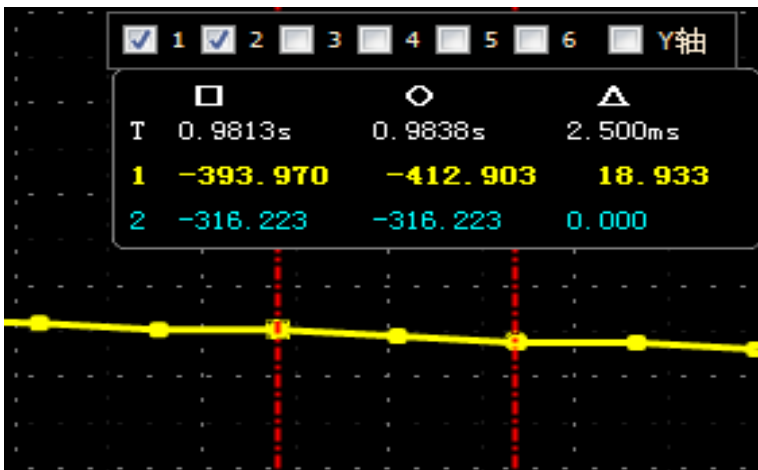



Y axis scale display/hide

The Y coordinate scale is displayed as a fixed value, and the Y axis scale display/hide can be modified through the toolbar settings.

Steps:

- Click the top right corner of the oscilloscope interface and in the Y axis option, check the label visibility and scale visibility.

Y-axis curve display/hide

The Y-axis has multiple curves, which can be selected according to the channel. The Y-axis curve is displayed by default.



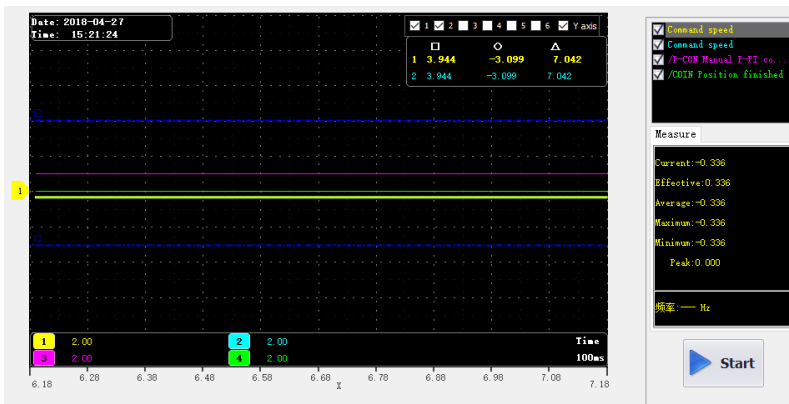

Steps:

a). In the interface of digital oscilloscope, remove the unnecessary waveform options, and the corresponding Y-axis curve will be automatically hidden in the graphics; for example, let the position instruction speed waveform be hidden, remove the check signal in the corresponding options as shown in the following figure.



Curve zooms in/out

Steps:

- Zoom in the area: Press the left mouse button and pull a zone from the upper left corner to the lower right corner, this area can be enlarged.
- Zoom out the area: Press the left mouse button and pull a zone from the lower right corner to the upper left corner, this area can be reduced.
- Zoom in curve X/Y: click on the button .
- Zoom out curve X/Y: click on the button .
- Zoom in curve X: Click on the button  to decrease the time in the options.
- Zoom out curve X: Click on the button  to increase the time in the options.
- Zoom in curve Y: Click on the gain option of the corresponding curve to decrease the gain value. As shown in the figure below, you can adjust the gain of six Y curves.
- Zoom out curve Y: Click on the gain option of the corresponding curve to increase the gain value. As shown below:



Curve translation



Steps:

- a). Horizontal panning of the curve: left-click on the toolbar , move left and right and move right and left fast (Note: When you move to the right to the maximum scale point, it will no longer move to the right).
- b). A single curve vertical translation: left-click and hold the corresponding curve number and drag it up and down to perform a vertical translation.

Graphic import/export:

According to the current graph, data and pictures can be exported at the same time. Only the bak format export is supported. In addition, the exported data can be imported for viewing.

Steps:

- a). Data import: Click the digital oscilloscope toolbar icon  to pop up the open dialog box and find the existing file.
- b). Data export: Click the toolbar icon  to pop up the save dialog and save it to the specified path.

Background:

Digital oscilloscope display area provides two backgrounds, black color and white color.

Steps:

- a). Click the icon  on the oscilloscope toolbar to display the prompt interface. As shown in the figure below, click OK to switch the display interface.

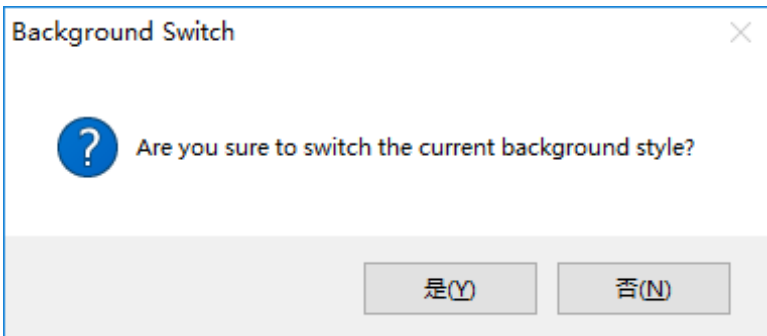

14.7 Others

14.7.1 Window Display

The window display is divided into: cascade, horizontal, vertical display, all off;

1. Cascade: click on the main menu of the host computer window [window] -> [cascade display];

2. Horizontal: click on the host computer interface menu bar [window] -> [horizontal display];
3. vertical: click on the main interface of the host computer menu window [window] -> [vertical display];
4. Close: Click on the main window of the host computer menu bar [Window] -> [Close all].

14.7.2 Help

Provide servo debug software version and other information, as well as servo drive arm version number, FPGA version number, and some related information of motor, etc.

Steps:

Click the menu bar [Help]->[Product Information] to display the servo unit information, Click the menu bar [Help] -> [About the software] to show the software version information.



15 Appendix

15.1 Compliance with Certification and Standard Requirements

Product directive table

Certification name	Directive name		Standard compliance
CE certification	EMC Directive	2014/30/EU	EN IEC 61800-3
	LVD Directive	2014/35/EU	EN 61800-5-1 EN 60034

15.1.1 CE Certification



Figure 15-1 CE certification mark

- "CE Marking" is a mark that indicates compliance with the Low Voltage Safety (LVD) and Electromagnetic Compatibility (EMC) Directives for commercial trade (production, import, and sale) in the European region.

The CE mark is required for commercial trade (production, import, and sales) in the European region.

- This product complies with the Low Voltage Directive (LVD) and Electromagnetic Compatibility (EMC), and is labeled with the CE mark.
- Machinery and devices in which this product is installed must also meet CE requirements when sold in the European region.
- When the CE mark is affixed to the terminal where this product is installed, the responsibility shall be borne by the customer who finally assembles the product, and it is up to the customer to confirm that the machinery and devices of the final product comply with CE marking.

15.1.2 Conditions of Compliance with EMC Directive

This product complies with the European EMC Directive 2014/30/EU and meets the requirements of the standard EN IEC 61800-3 and is suitable for both Type I and Type II environments.

In order to make this product comply with EMC Directive and standard requirements, it is necessary to install EMC filter on the input side of the driver and select the recommended shielded cable on the output side, and it is necessary to comply with the cabinet installation requirements to ensure

reliable grounding of the filter and reliable 360° lap of the output cable shield.

Note: If used in a Type I environment, this product may cause radio interference. In addition to the CE compliance requirements mentioned in this chapter, the user should take measures to prevent external interference when necessary.

15.1.3 EMC Standard Introduction

EMC (Electromagnetic Compatibility) refers to the ability of electrical and electronic equipment to work normally in an environment with electromagnetic interference, and the ability not to release excessive electromagnetic interference to other local equipment or systems so as not to affect the stable work of other equipment. Therefore, EMC includes two requirements: on the one hand, it means that the electromagnetic interference generated by the equipment to the environment where it is located during normal operation cannot exceed a certain limit; on the other hand, it means the ability to work normally with a certain degree of immunity to the electromagnetic interference present in the environment, i.e. electromagnetic sensitivity.

EN IEC 61800-3 defines the following two types of environments:

- Type I environment: Facilities that include civil environments and also include facilities that are directly connected to the low-voltage grid supplying power to civil buildings without an intermediate transformer.
- Type II environment: Facilities other than those directly connected to the low-voltage grid supplying power to residential buildings.

The products are classified into the following four categories according to the intended use environment:

- Category C1 equipment: Electrical drive systems with a rated power supply of less than 1000V, used in the first environment.
- Category C2 equipment: The rated voltage of the electrical drive system is less than 1000 V. It cannot be plug-in equipment or removable equipment, and can only be installed and commissioned by professionals when used in the first environment.
- Category C3 equipment: The rated voltage of the electrical drive system is less than 1000 V. It is suitable for the second environment, but not for the first environment.
- Category C4 equipment: The rated voltage of the electrical drive system is not less than 1000 V, or the rated current is not less than 400 A, or in a complex system suitable for the second environment.

15.1.4 Conditions of compliance with the LVD Low Voltage Directive

This product has been tested in accordance with EU safety standard EN61800-5-1 and is confirmed to comply with the Low Voltage Directive. The following requirements need to be met in order for the machinery and devices in which this product is installed to comply with the low voltage directive.

Installation Site

Please install this product in places with overvoltage level III and pollution level 2 or less as specified in IEC 60664-1.

Installation Environment

See ["1.4.4 Installation Environment Requirements"](#) on page 16 for installation environment

requirements.

Installation Protection Requirements

This product is a control cabinet mounted product and needs to be installed in the final system for use. The final system should be provided with the appropriate fireproof enclosure, electrical enclosure and mechanical enclosure, etc., and comply with local laws and regulations and relevant IEC standard requirements.

When installing the in-cabinet mounting type (IP20) products, please install them in a structure where external objects cannot enter from the top and front.

Main Circuit Wiring Requirements

Main circuit terminal wiring requirements, please refer to page 41 "[3.1.4](#) Main circuit wiring requirements" for details.

Protection Device Requirements

In order to meet the requirements of the European Union safety standard EN 61800-5-1, please be sure to connect the fuse/circuit breaker at the input side to prevent accidents caused by internal circuit short circuit.

Install sufficient branch circuit short circuit protection devices in accordance with applicable regulations and this manual. This product is applicable to circuits with rated fusing capacity below 5000A and maximum voltage of 440VAC (Class 400).

Refer to the selection table of "fuse" and "circuit breaker" in the manual for the recommended selection requirements of fuse/filter.

Scan the following QR code to download the relevant electronic files:



SD700 Servo drive manual



SD700 Servo product catalog